



Tekla Structures 2023

Advanced options

April 2023

©2023 Trimble Solutions Corporation

Contents

| | | |
|----------|--|-----------|
| 1 | Advanced options..... | 27 |
| 2 | Advanced options - A..... | 29 |
| 2.1 | XS_AD_ANALYSIS_PLANES_ENABLED..... | 29 |
| 2.2 | XS_AD_CURVED_BEAM_SPLIT_ACCURACY_MM | 29 |
| 2.3 | XS_AD_DRAW_BAR_DIAMETER_MM..... | 30 |
| 2.4 | XS_AD_DRAW_NODE_SCALE..... | 30 |
| 2.5 | XS_AD_ELEMENT_ANGLE_CHECK_ANGLE_DIFF_LIMIT | 31 |
| 2.6 | XS_AD_ENVIRONMENT..... | 31 |
| 2.7 | XS_AD_GET_MOMENT_CONNECTION_STATUS..... | 32 |
| 2.8 | XS_AD_GET_RESULTS_DESIGN_VALUES..... | 32 |
| 2.9 | XS_AD_GET_RESULTS_FORCES..... | 33 |
| 2.10 | XS_AD_LOAD_COMBINATION_METHOD..... | 33 |
| 2.11 | XS_AD_MEMBER_NUMBER_VISUALIZATION | 33 |
| 2.12 | XS_AD_MEMBER_RESULT_DISP_DIVISION_COUNT..... | 34 |
| 2.13 | XS_AD_MEMBER_RESULT_DIVISION_COUNT..... | 34 |
| 2.14 | XS_AD_MEMBER_RESULT_GRID_SIZE..... | 35 |
| 2.15 | XS_AD_MEMBER_RESULT_MIN_DISTANCE..... | 35 |
| 2.16 | XS_AD_MEMBER_TYPE_VISUALIZATION | 35 |
| 2.17 | XS_AD_NEAR_NODES_WARNING_LIMIT..... | 36 |
| 2.18 | XS_AD_NODE_NUMBER_BY_Z..... | 36 |
| 2.19 | XS_AD_NODE_NUMBER_VISUALIZATION..... | 36 |
| 2.20 | XS_AD_OPTIMISATION_DISABLED | 37 |
| 2.21 | XS_AD_OPTIMISATION_NO_WEIGHT_SORT..... | 37 |
| 2.22 | XS_AD_OPTIMISATION_RECURSE_CATALOG | 37 |
| 2.23 | XS_AD_RESULT_DATABASE_ENABLED..... | 38 |
| 2.24 | XS_AD_RIGID_DIAPHRAGM_VISUALIZATION..... | 38 |
| 2.25 | XS_AD_SHORT_MEMBER_WARNING_LIMIT..... | 39 |
| 2.26 | XS_AD_SHORT_RIGIDLINK_WARNING_LIMIT..... | 39 |
| 2.27 | XS_AD_SOLID_AXIAL_EXPAND_MM..... | 40 |
| 2.28 | XS_AD_SOLID_SECONDARY_EXPAND_MM..... | 40 |
| 2.29 | XS_AD_SUPPORT_VISUALIZATION | 40 |
| 2.30 | XS_AD_USE_HIGH_ACCURACY..... | 41 |
| 2.31 | XS_ADAPTIVE_OBJECTS..... | 41 |
| 2.32 | XS_ADD_SNAPPING_SYMBOL_TO_CIRCLES..... | 41 |

| | | |
|------|---|----|
| 2.33 | XS_ADJUST_GRID_LABELS | 42 |
| 2.34 | XS_AISC_WELD_MARK | 42 |
| 2.35 | XS_ALLOW_DRAWING_TO_MANY_MULTI_DRAWINGS | 43 |
| 2.36 | XS_ALLOW_INCH_MARK_IN_DIMENSIONS | 43 |
| 2.37 | XS_ALLOW_INCH_MARK_IN_WELD_SYMBOLS | 44 |
| 2.38 | XS_ALLOW_REBARS_ON_TOP_OF_EACH_OTHER | 44 |
| 2.39 | XS_ALLOW_REINFORCING_LOCKED_PARTS | 45 |
| 2.40 | XS_ALLOW_SHEAR_PLATE_CLASH_FLANGE | 45 |
| 2.41 | XS_ALWAYS_CONFIRM_SAVE_WHEN_CLOSING_DRAWING | 45 |
| 2.42 | XS_ALWAYS_CONFIRM_SAVE_WHEN_EXIT | 46 |
| 2.43 | XS_ANCHOR_BOLT_PLAN_ADDITIONAL_PARTS_FILTER | 46 |
| 2.44 | XS_ANCHOR_BOLT_PLAN_BASEPLATE_FILTER | 47 |
| 2.45 | XS_ANCHOR_BOLT_PLAN_BOLT_FILTER | 48 |
| 2.46 | XS_ANCHOR_BOLT_PLAN_COLUMN_FILTER | 48 |
| 2.47 | XS_ANCHOR_BOLT_PLAN_DRAWING_TOLERANCE | 49 |
| 2.48 | XS_ANCHOR_BOLT_PLAN_USE_VIEW_COORDSYS_FOR_BOLT_ DIMENSIONS | 49 |
| 2.49 | XS_ANGLE_DEGREE_SIGN | 49 |
| 2.50 | XS_ANGLE_DIMENSION_SYMBOL_SIZE_FACTOR | 50 |
| 2.51 | XS_ANGLE_TEXT_IN_UNFOLDING_BENDING_LINE_DIMENSIONING | 50 |
| 2.52 | APPL_ERROR_LOG | 51 |
| 2.53 | XS_APPLICATIONS | 51 |
| 2.54 | XS_APPLICATIONS_PATH | 52 |
| 2.55 | XS_ARC_WIDTH_OF_CLOUD | 52 |
| 2.56 | XS_ASCII_IMPORT_CREATES_CONSTRUCTION_LINES | 53 |
| 2.57 | XS_ASSEMBLY_DRAWING_VIEW_TITLE | 53 |
| 2.58 | XS_ASSEMBLY_FAMILY_POSITION_NUMBER_FORMAT_STRING | 54 |
| 2.59 | XS_ASSEMBLY_MULTI_NUMBER_FORMAT_STRING | 56 |
| 2.60 | XS_ASSEMBLY_POSITION_CODE_3D | 57 |
| 2.61 | XS_ASSEMBLY_POSITION_CODE_TOLERANCE | 57 |
| 2.62 | XS_ASSEMBLY_POSITION_NEW_FORMAT | 57 |
| 2.63 | XS_ASSEMBLY_POSITION_NUMBER_FORMAT_STRING | 58 |
| 2.64 | XS_ASSOCIATIVE_CHANGE_HIGHLIGHT_SIZE | 59 |
| 2.65 | XS_ASSOCIATIVE_CHANGE_HIGHLIGHT_SYMBOL | 60 |
| 2.66 | XS_ATTRIBUTE_FILE_EXCLUDE_LIST | 60 |
| 2.67 | XS_AUTOCONNECTION_TOLERANCE | 61 |
| 2.68 | XS_AUTOCONNECTION_USE_UDL | 61 |
| 2.69 | XS_AUTODEFAULT_UDL_PERCENT | 61 |
| 2.70 | XS_AUTOMATIC_NEW_MODEL_NAME | 62 |
| 2.71 | XS_AUTOMATIC_USER_FEEDBACK_SAVING_INTERVAL | 62 |
| 2.72 | XS_AUTOMATIC_USER_FEEDBACK_SENDING_INTERVAL | 62 |

| | | |
|----------|--|-----------|
| 2.73 | XS_AUTOSAVE_DIRECTORY | 63 |
| 3 | Advanced options - B | 64 |
| 3.1 | XS_BACKGROUND_COLOR1 | 64 |
| 3.2 | XS_BACKGROUND_COLOR2 | 65 |
| 3.3 | XS_BACKGROUND_COLOR3 | 65 |
| 3.4 | XS_BACKGROUND_COLOR4 | 65 |
| 3.5 | XS_BASE_LINE_WIDTH | 65 |
| 3.6 | XS_BASE_LINE_WIDTH_AFFECTS_SCREEN | 66 |
| 3.7 | XS_BASICVIEW_HEIGHT | 66 |
| 3.8 | XS_BASICVIEW_POSITION_X | 67 |
| 3.9 | XS_BASICVIEW_POSITION_Y | 67 |
| 3.10 | XS_BASICVIEW_WIDTH | 68 |
| 3.11 | XS_BEVEL_DIMENSIONS_FOR_PROFILES_ONLY | 68 |
| 3.12 | XSBIN | 68 |
| 3.13 | XS_BLACK_DRAWING_BACKGROUND | 69 |
| 3.14 | XS_BOLT_DUPLICATE_IGNORE | 70 |
| 3.15 | XS_BOLT_DUPLICATE_TOLERANCE | 71 |
| 3.16 | XS_BOLT_LENGTH_EPSILON | 71 |
| 3.17 | XS_BOLT_MARK_DIAMETER_PREFIX | 71 |
| 3.18 | XS_BOLT_MARK_IS_ALWAYS_VISIBLE | 72 |
| 3.19 | XS_BOLT_MARK_IS_ALWAYS_VISIBLE_IN_GA | 72 |
| 3.20 | XS_BOLT_MARK_STRING_FOR_SIZE | 73 |
| 3.21 | XS_BOLT_MARK_STRING_FOR_SIZE_IN_GA | 74 |
| 3.22 | XS_BOLT_POSITION_TO_MIN_AND_MAX_POINT | 75 |
| 3.23 | XS_BOLT_REPRESENTATION_SYMBOL_AXIS_POSITION_AS_EXACT_SOLID .. | 76 |
| 3.24 | XS_BOLT_REPRESENTATION_USE_POSITIVE_CUT_LENGTH | 77 |
| 3.25 | XS_BOLTS_PERPENDICULAR_TO_PART_PLANE_IN_NC | 78 |
| 4 | Advanced options - C | 79 |
| 4.1 | XS_CALCULATE_POLYBEAM_LENGTH_ALONG_REFERENCE_LINE | 79 |
| 4.2 | XS_CALCULATE_POUR_UNITS_ON_SHARING | 80 |
| 4.3 | XS_CAST_UNIT_FAMILY_POSITION_NUMBER_FORMAT_STRING | 80 |
| 4.4 | XS_CAST_UNIT_MULTI_NUMBER_FORMAT_STRING | 82 |
| 4.5 | XS_CAST_UNIT_POSITION_NUMBER_FORMAT_STRING | 83 |
| 4.6 | XS_CENTER_LINE_TYPE | 85 |
| 4.7 | XS_CENTER_TO_CENTER_DISTANCE_IN_ONE_PART_STRING | 85 |
| 4.8 | XS_CENTER_TO_CENTER_DISTANCE_IN_TWO_PARTS_STRING | 86 |
| 4.9 | XS_CHAMFER_ACCURACY_FACTOR | 87 |
| 4.10 | XS_CHAMFER_DISPLAY_LENGTH_FACTOR | 88 |
| 4.11 | XS_CHANGE_DRAGGED_DIMENSIONS_TO_FIXED | 88 |

| | | |
|------|---|-----|
| 4.12 | XS_CHANGE_DRAGGED_MARKS_TO_FIXED | 88 |
| 4.13 | XS_CHANGE_DRAGGED_NOTES_TO_FIXED | 89 |
| 4.14 | XS_CHANGE_DRAGGED_TEXTS_TO_FIXED | 89 |
| 4.15 | XS_CHANGE_DRAGGED_VIEWS_TO_FIXED | 89 |
| 4.16 | XS_CHANGE_MARK_ASTERISK_TO | 90 |
| 4.17 | XS_CHANGE_WORKAREA_WHEN_MODIFYING_VIEW_DEPTH | 90 |
| 4.18 | XS_CHECK_BOLT_EDGE_DISTANCE_ALWAYS | 91 |
| 4.19 | XS_CHECK_FLAT_LENGTH_ALSO | 91 |
| 4.20 | XS_CHECK_TRIANGLE_TEXT_SIZE | 91 |
| 4.21 | XS_CHORD_TOLERANCE_FOR_SMALL_TUBE_SEGMENTS | 92 |
| 4.22 | XS_CHORD_TOLERANCE_FOR_TUBE_SEGMENTS | 93 |
| 4.23 | XS_CHORD_TOLERANCE_SMALL_TUBE_SIZE_LIMIT | 93 |
| 4.24 | XS_CIS_DEP1_DATABASE_NAME | 94 |
| 4.25 | XS_CIS_DEP1_DATABASE_PASSW | 94 |
| 4.26 | XS_CIS_DEP1_DATABASE_PATH | 95 |
| 4.27 | XS_CIS_DEP1_EXPRESS_FILE | 95 |
| 4.28 | XS_CLASH_CHECK_BETWEEN_REINFORCING_BARS | 95 |
| 4.29 | XS_CLEAR_MODEL_HISTORY | 96 |
| 4.30 | XS_CLONING_TEMPLATE_DIRECTORY | 96 |
| 4.31 | XS_CLOUD_SHARING_PROXY | 96 |
| 4.32 | XS_CNC_CUT_PLANE_HEIGHT | 97 |
| 4.33 | XS_CNC_HOLE_DIAMETER_ROUNDING | 97 |
| 4.34 | XS_COLLECT_MODEL_HISTORY | 98 |
| 4.35 | XS_COMBINED_BOLT_DIM_CHARACTER | 98 |
| 4.36 | XS_COMPANY_SETTINGS_DIRECTORY | 99 |
| 4.37 | XS_COMPLEX_PART_MEMBERS_DO_NOT_HAVE_TO_BE_MAIN_PARTS | 99 |
| 4.38 | XS_COMPONENT_CATALOG_ALLOW_SYSTEM_EDIT | 99 |
| 4.39 | XS_COMPONENT_CATALOG_DO_REPORT_LEGACY_FILE_ISSUES | 99 |
| 4.40 | XS_COMPONENT_CATALOG_COMPACT_THUMBNAIL_SIZE | 100 |
| 4.41 | XS_COMPONENT_CATALOG_THUMBNAIL_SIZE | 100 |
| 4.42 | XS_CONCRETE_PART_NUMBERING_PREFIX | 101 |
| 4.43 | XS_CONCRETE_PART_NUMBERING_START_NUMBER | 101 |
| 4.44 | XS_CONNECTING_SIDE_MARK_SYMBOL | 101 |
| 4.45 | XS_CONNECT_CONNECTION_PARTS_IN_AUTOCONNECTION | 102 |
| 4.46 | XS_CONNECT_PLATE_PROFILES_IN_AUTOCONNECTION | 102 |
| 4.47 | XS_CONNECT_UPLOAD_MODEL_FOLDER | 102 |
| 4.48 | XS_CONSIDER_NEIGHBOUR_PARTS_IN_HIDDEN | 103 |
| 4.49 | XS_CONSIDER_REBAR_HOOK_LOCATION_IN_CAST_UNIT_NUMBERING | 104 |
| 4.50 | XS_CONSIDER_REBAR_NAME_IN_NUMBERING | 104 |
| 4.51 | XS_CONTOUR_PLATE_POINT_ON_SAME_LINE_LIMIT | 104 |
| 4.52 | XS_CONTOUR_PLATE_POINT_ON_SAME_LINE_LIMIT_FOR_CLOSE_POINTS | 105 |

| | | |
|----------|---|------------|
| 4.53 | XS_CONVERSION_ARBITRARY_PROFILE_MAPPING_BY_NAME_MUST_MATCH_DIMENSIONS..... | 105 |
| 4.54 | XS_CONVERT_OLD_FORCE_UNITS_TO_SI_FROM | 106 |
| 4.55 | XS_CONVERT_OLD_MOMENT_UNITS_TO_SI_FROM | 106 |
| 4.56 | XS_COPY_REVISIONS_IN_AUTOMATIC_CLONING..... | 106 |
| 4.57 | XS_COUNT_ALL_PARTS_IN_NSFS_REPEATED_PART_MARK | 107 |
| 4.58 | XS_COUNT_BOTH_PARTS_IN_NSFS_PART_MARK | 107 |
| 4.59 | XS_CREATE_ALSO_BIG_HTML_REPORT_PICTURES..... | 108 |
| 4.60 | XS_CREATE_DRAWING_PREVIEW_AUTOMATICALLY..... | 108 |
| 4.61 | XS_CREATE_MISSING_MARKS_IN_INTELLIGENT_CLONING..... | 108 |
| 4.62 | XS_CREATE_ROUND_HOLE_DIMENSIONS | 109 |
| 4.63 | XS_CREATE_CONNECTION_WHEN_COPYING_DRAWING_VIEWS | 110 |
| 4.64 | XS_DRAWING_CREATE_SNAPSHOT_ON_DRAWING_CREATION..... | 110 |
| 4.65 | XS_CREATE_VIEW_FROM_MODEL_OLD_WAY | 110 |
| 4.66 | XS_CS_CHAMFER_DIVIDE_ANGLE | 111 |
| 4.67 | XS_CURVED_AXIS_PLACE | 112 |
| 4.68 | XS_CUSTOM_COMPONENT_DECIMALS..... | 112 |
| 4.69 | XS_CUT_SYMBOL_FONT | 112 |
| 4.70 | XS_CYCLIC_SOLVER_MAX_LOOPS | 113 |
| 5 | Advanced options - D..... | 114 |
| 5.1 | DAK_BMPPATH | 114 |
| 5.2 | XSDATADIR..... | 114 |
| 5.3 | XS_DEFAULT_BREP_PATH..... | 115 |
| 5.4 | XS_DEFAULT_ENVIRONMENT..... | 116 |
| 5.5 | XS_DEFAULT_FONT | 116 |
| 5.6 | XS_DEFAULT_FONT_SIZE | 117 |
| 5.7 | XS_DEFAULT_HEIGHT_FOR_CALCULATED_DRAWING_SIZE..... | 117 |
| 5.8 | XS_DEFAULT_KEEP_ONLINE_LICENSE_CHECKBOX..... | 117 |
| 5.9 | XS_DEFAULT_LICENSE..... | 118 |
| 5.10 | XS_DEFAULT_MODEL_TEMPLATE..... | 119 |
| 5.11 | XS_DEFAULT_ROLE..... | 119 |
| 5.12 | XS_DEFAULT_UNICODE_FONT_DRAWING_PRINTING..... | 120 |
| 5.13 | XS_DEFAULT_WIDTH_FOR_CALCULATED_DRAWING_SIZE..... | 120 |
| 5.14 | XS_DELETE_UNNECESSARY_DG_FILES..... | 121 |
| 5.15 | XS_DELETE_UNNECESSARY_DG_FILES_SAFETY_PERIOD..... | 121 |
| 5.16 | XS_DELETE_UNNECESSARY_REFMODEL_FILES_SAFETY_PERIOD | 122 |
| 5.17 | XS_DETAIL_BOUNDARY_RADIUS | 122 |
| 5.18 | XS_DETAIL_MARK_REFERENCE_SYMBOL..... | 122 |
| 5.19 | XS_DETAIL_SYMBOL_REFERENCE | 123 |
| 5.20 | XS_DETAIL_VIEW_REFERENCE | 124 |

| | | |
|------|---|-----|
| 5.21 | XS_DGN_EXPORT_PART_AS | 125 |
| 5.22 | XS_DGN_EXPORT_USE_LOCAL_ID | 125 |
| 5.23 | XS_DIAGNOZE_AND_REPAIR_WRONG_UDA_TYPE | 125 |
| 5.24 | XS_DIALOG_ENABLE_STATE | 126 |
| 5.25 | XS_DIMENSION_ALL_BOLT_GROUPS_SEPARATELY | 126 |
| 5.26 | XS_DIMENSION_DECIMAL_SEPARATOR | 127 |
| 5.27 | XS_DIMENSION_DIGIT_GROUPING_CHARACTER | 128 |
| 5.28 | XS_DIMENSION_DIGIT_GROUPING_COUNT | 128 |
| 5.29 | XS_DIMENSION_EXTENSION_LINE_AWAY_FACTOR | 129 |
| 5.30 | XS_DIMENSION_EXTENSION_LINE_ORIGIN_OFFSET | 129 |
| 5.31 | XS_DIMENSION_EXTENSION_LINE_TOWARD_FACTOR | 130 |
| 5.32 | XS_DIMENSION_FONT | 130 |
| 5.33 | XS_DIMENSION_GROUPING_COUNT_SEPARATOR | 131 |
| 5.34 | XS_DIMENSION_LINE_TEXT_EPS | 131 |
| 5.35 | XS_DIMENSION_MARK_CONNECTOR | 131 |
| 5.36 | XS_DIMENSION_MARK_CREATE_MIDDLE_TAG_ALWAYS | 132 |
| 5.37 | XS_DIMENSION_MARK_MULTIPLIER | 132 |
| 5.38 | XS_DIMENSION_PART_MARK_CONTENT_IN_ASSEMBLY | 132 |
| 5.39 | XS_DIMENSION_PART_MARK_CONTENT_IN_SINGLE | 133 |
| 5.40 | XS_DIMENSION_PART_MARK_CONTENT_STRICT_POSITION | 134 |
| 5.41 | XS_DIMENSION_PLATE_SIDE_MARK_SYMBOL_CENTER | 135 |
| 5.42 | XS_DIMENSION_PLATE_SIDE_MARK_SYMBOL_LEFT | 135 |
| 5.43 | XS_DIMENSION_PLATE_SIDE_MARK_SYMBOL_RIGHT | 135 |
| 5.44 | XS_DIMENSION_SKEWED_BOLTS_IN_PART_PLANE_IN_SINGLE_DRAWINGS | 136 |
| 5.45 | XS_DIR | 136 |
| 5.46 | XS_DISABLE_ADVANCED_OPTIONS | 136 |
| 5.47 | XS_DISABLE_ANALYSIS_AND_DESIGN | 137 |
| 5.48 | XS_DISABLE_CANCEL_DIALOG_FOR_SAVE_NUMBERING_SAVE | 137 |
| 5.49 | XS_DISABLE_CLASSIFIER_FOR_MODIFIED_PARTS | 137 |
| 5.50 | XS_DISABLE_DRAWING_PLOT_DATE | 138 |
| 5.51 | XS_DISABLE_PARTIAL_REFRESH | 138 |
| 5.52 | XS_DISABLE_REBAR_MODELING | 138 |
| 5.53 | XS_DISABLE_TEMPLATE_DOUBLE_CLICK | 139 |
| 5.54 | XS_DISABLE_VIEW_CENTERING_ASSEMBLY | 139 |
| 5.55 | XS_DISABLE_VIEW_CENTERING_GA | 140 |
| 5.56 | XS_DISABLE_VIEW_CENTERING_MULTI | 140 |
| 5.57 | XS_DISABLE_VIEW_CENTERING_SINGLE | 140 |
| 5.58 | XS_DISPLAY_DIMENSIONS_WHEN_CREATING_OBJECTS | 140 |
| 5.59 | XS_DISPLAY_DIMENSIONS_WHEN_SELECTING_OBJECTS | 141 |
| 5.60 | XS_DISPLAY_DIMENSIONS_WHEN_SELECTING_REBARS | 142 |

| | | |
|-------|---|-----|
| 5.61 | XS_DISPLAY_FILLET_EDGES..... | 143 |
| 5.62 | XS_DISPLAY_ZERO_INCHES | 144 |
| 5.63 | XS_DISTANT_OBJECT_FINDER_TOLERANCE..... | 144 |
| 5.64 | XS_DO_NOT_CLIP_NATIVE_OBJECTS_WITH_CLIP_PLANE..... | 144 |
| 5.65 | XS_DO_NOT_CREATE_ASSEMBLY_DRAWINGS_FOR_CONCRETE_PARTS | 145 |
| 5.66 | XS_DO_NOT_CREATE_ASSEMBLY_DRAWINGS_FOR_LOOSE_PARTS..... | 145 |
| 5.67 | XS_DO_NOT_CREATE_BOLT_MARKS_IN_ALL_INCLUDED_SINGLE_VIEWS.... | 145 |
| 5.68 | XS_DO_NOT_CREATE_PART_MARKS_IN_ALL_INCLUDED_SINGLE_VIEWS.... | 146 |
| 5.69 | XS_DO_NOT_CREATE_PROFILE_DIMENSIONS_FOR_CONCRETE | 146 |
| 5.70 | XS_DO_NOT_DISPLAY_CHAMFERS | 147 |
| 5.71 | XS_DO_NOT_DRAW_COLUMN_MARKS_AT_45_DEGREES_IN_GA_DRAWING | 147 |
| 5.72 | XS_DO_NOT_EXTEND_DIMENSION_LINES_THROUGH_ALL_HOLES | 148 |
| 5.73 | XS_DO_NOT_PLOT_DIMENSION_POINT_CIRCLES | 149 |
| 5.74 | XS_DO_NOT_OVERWRITE_PLUGIN_INP_FILE..... | 149 |
| 5.75 | XS_DO_NOT_REMOVE_END_ABSOLUTE_DIMENSIONS | 150 |
| 5.76 | XS_DO_NOT_USE_FOLDED_GUSSET_PLATE | 151 |
| 5.77 | XS_DO_NOT_USE_GLOBAL_PLATE_SIDE | 151 |
| 5.78 | XS_DONT_SHOW_POLYBEAM_MID_EDGES | 151 |
| 5.79 | XS_DRAW_ALL_SECTION_EDGES_IN_DRAWINGS..... | 153 |
| 5.80 | XS_DRAW_ANGLE_AND_RADIUS_INFO_IN_UNFOLDING | 153 |
| 5.81 | XS_DRAW_BENDING_END_LINE_DIMENSIONS_IN_UNFOLDING..... | 153 |
| 5.82 | XS_DRAW_BENDING_END_LINES_IN_UNFOLDING..... | 154 |
| 5.83 | XS_DRAW_BENDING_LINE_DIMENSIONS_IN_UNFOLDING | 154 |
| 5.84 | XS_DRAW_BOLT_HIDDEN_LINES | 154 |
| 5.85 | XS_DRAW_BOLT_HIDDEN_LINES_IN_ASSEMBLY_DRAWINGS | 156 |
| 5.86 | XS_DRAW_BOLT_HIDDEN_LINES_IN_GA_DRAWINGS | 157 |
| 5.87 | XS_DRAW_BOLT_HIDDEN_LINES_IN_SINGLE_DRAWINGS | 157 |
| 5.88 | XS_DRAW_BOLT_OWN_HIDDEN_LINES | 158 |
| 5.89 | XS_DRAW_BOLT_OWN_HIDDEN_LINES_IN_ASSEMBLY_DRAWINGS | 158 |
| 5.90 | XS_DRAW_BOLT_OWN_HIDDEN_LINES_IN_GA_DRAWINGS | 159 |
| 5.91 | XS_DRAW_BOLT_OWN_HIDDEN_LINES_IN_SINGLE_DRAWINGS | 159 |
| 5.92 | XS_DRAW_BOLTS_3D_IN_BOLT_LAYER..... | 160 |
| 5.93 | XS_DRAW_BOLTS_PERPENDICULAR_TO_PART_IN_SINGLE_DRAWINGS | 160 |
| 5.94 | XS_DRAW_BOLTS_THROUGH_NEIGHBOUR_PARTS | 161 |
| 5.95 | XS_DRAW_CAST_PHASE_INTERNAL_LINES | 162 |
| 5.96 | XS_DRAW_CAST_UNIT_INTERNAL_LINES | 163 |
| 5.97 | XS_DRAW_CHAMFERS_HANDLES | 163 |
| 5.98 | XS_DRAW_CROSS_AXIS | 164 |
| 5.99 | XS_DRAW_CUT_FACES_WITH_OBJECT_COLOR..... | 165 |
| 5.100 | XS_DRAW_HIDDEN_FACES | 165 |

| | | |
|-------|--|-----|
| 5.101 | XS_DRAW_HORIZONTAL_VIEW_SHORTENING_SYMBOLS_TO_PARTS..... | 166 |
| 5.102 | XS_DRAW_INSIDE_ANGLE_IN_UNFOLDING | 167 |
| 5.103 | XS_DRAW_LONG_HOLE_DIMENSIONS | 167 |
| 5.104 | XS_DRAW_MESH_OUTLINE_SYMBOL_FROM_BOTTOM_LEFT_TO_TOP_RIGHT..... | 167 |
| 5.105 | XS_DRAW_REBAR_HIDDEN_FACES..... | 168 |
| 5.106 | XS_DRAW_REBAR_SELF_INTERSECTING_LEGS_WITH_OFFSET..... | 169 |
| 5.107 | XS_DRAW_ROOT_OPENING_EVEN_WHEN_ZERO..... | 171 |
| 5.108 | XS_DRAW_SHORT_LEADER_LINES_OF_PART_MARKS | 171 |
| 5.109 | XS_DRAW_SHORT_LEADER_LINES_OF_PART_MARKS_MINIMUM_LENGTH. | 172 |
| 5.110 | XS_DRAW_SKEWED_ELEVATIONS | 172 |
| 5.111 | XS_DRAW_VERTICAL_VIEW_SHORTENING_SYMBOLS_TO_PARTS..... | 172 |
| 5.112 | XS_DRAWING_ALLOW_NEW_SECTIONS_IN_REDIMENSIONING..... | 173 |
| 5.113 | XS_DRAWING_ALLOW_SNAPPING_TO_DISTANT_POINTS..... | 174 |
| 5.114 | XS_DRAWING_ASSEMBLY_HATCH_SCHEMA | 174 |
| 5.115 | XS_DRAWING_CAST_UNIT_HATCH_SCHEMA | 175 |
| 5.116 | XS_DRAWING_CHANGE_HIGHLIGHT_COLOR | 175 |
| 5.117 | XS_DRAWING_CLONING_IGNORE_CHECK..... | 176 |
| 5.118 | XS_DRAWING_COMBINE_ADDED_DIMENSIONS..... | 177 |
| 5.119 | XS_DRAWING_CUT_VIEW_COMPARISON_CRITERIA | 177 |
| 5.120 | XS_DRAWING_FILTER_UDAS_WITHOUT_TYPE_CHECK..... | 178 |
| 5.121 | XS_DRAWING_GA_HATCH_SCHEMA | 178 |
| 5.122 | XS_DRAWING_GRID_LABEL_FRAME_FIXED_WIDTH..... | 179 |
| 5.123 | XS_DRAWING_GRID_LABEL_FRAME_LINE_WIDTH_FACTOR | 180 |
| 5.124 | XS_DRAWING_HISTORY_LOG_TYPE | 180 |
| 5.125 | XS_DRAWING_IGNORE_ZERO_LEVELS_IN_PART_MARKS | 181 |
| 5.126 | XS_DRAWING_PART_REFERENCE_LINE_TYPE | 181 |
| 5.127 | XS_DRAWING_PART_SYMBOL_REPRESENTATION_TYPE..... | 182 |
| 5.128 | XS_DRAWING_PLOT_FILE_DIRECTORY | 182 |
| 5.129 | XS_DRAWING_PLOT_FILE_NAME | 183 |
| 5.130 | XS_DRAWING_PLOT_FILE_NAME_A | 184 |
| 5.131 | XS_DRAWING_PLOT_FILE_NAME_W | 186 |
| 5.132 | XS_DRAWING_PLOT_FILE_NAME_G | 187 |
| 5.133 | XS_DRAWING_PLOT_FILE_NAME_M | 189 |
| 5.134 | XS_DRAWING_PLOT_FILE_NAME_C | 190 |
| 5.135 | XS_DRAWING_POINT_SCALE | 192 |
| 5.136 | XS_DRAWING_RENDERING_ENGINE..... | 192 |
| 5.137 | XS_DRAWING_SCALE_SEPARATOR_CHAR | 193 |
| 5.138 | XS_DRAWING_SHEET_HEIGHT | 193 |
| 5.139 | XS_DRAWING_SHEET_POSITION_X | 193 |
| 5.140 | XS_DRAWING_SHEET_POSITION_Y | 194 |

| | | |
|-------|--|-----|
| 5.141 | XS_DRAWING_SHEET_WIDTH | 195 |
| 5.142 | XS_DRAWING_SINGLE_PART_HATCH_SCHEMA | 195 |
| 5.143 | XS_DRAWING_SNAPSHOT_CREATION..... | 195 |
| 5.144 | XS_DRAWING_SOLID_MERGE_TOLERANCE..... | 196 |
| 5.145 | XS_DRAWING_STUD_REPRESENTATION..... | 198 |
| 5.146 | XS_DRAWING_TEMPLATES_LIBRARY | 199 |
| 5.147 | XS_DRAWING_UDAS_MODIFY_ALL_DRAWING_TYPES | 200 |
| 5.148 | XS_DRAWING_UPDATE_VIEW_PLACING | 200 |
| 5.149 | XS_DRAWING_USE_WORKSHOP_FORM _FOR_DOUBLE_PARTS_IN_SINGLE_PART_DRAWINGS..... | 201 |
| 5.150 | XS_DRAWING_VIEW_DIRECTION_MARK_SYMBOL_FRONT | 202 |
| 5.151 | XS_DRAWING_VIEW_DIRECTION_MARK_SYMBOL_TOP | 203 |
| 5.152 | XS_DRAWING_VIEW_DIRECTION_MARK_SYMBOL_BACK | 204 |
| 5.153 | XS_DRAWING_VIEW_DIRECTION_MARK_SYMBOL_BOTTOM | 204 |
| 5.154 | XS_DRAWING_VIEW_REFERENCE_SYMBOL | 205 |
| 5.155 | XS_DRIVER | 205 |
| 5.156 | XS_DSTV_CREATE_AK_BLOCK_FOR_ALL_PLATES..... | 205 |
| 5.157 | XS_DSTV_CREATE_AK_BLOCK_FOR_ALL_PROFILES..... | 206 |
| 5.158 | XS_DSTV_CREATE_NOTCH_ONLY_ON_BEAM_CORNERS..... | 206 |
| 5.159 | XS_DSTV_DO_NOT_UNFOLD_POLYBEAM_PLATES..... | 208 |
| 5.160 | XS_DSTV_LIST_NET_WEIGHT..... | 209 |
| 5.161 | XS_DSTV_LIST_SEPARATOR | 210 |
| 5.162 | XS_DSTV_NET_LENGTH | 210 |
| 5.163 | XS_DSTV_NO_SAWING_ANGLES_FOR_PLATES_NEEDED..... | 211 |
| 5.164 | XS_DSTV_NUMBER_OF_PARTS_BY_SELECTION..... | 211 |
| 5.165 | XS_DSTV_PLATE_PROFILE_WITH_WIDTH..... | 212 |
| 5.166 | XS_DSTV_PRINT_NET_AND_GROSS_LENGTH | 212 |
| 5.167 | XS_DSTV_REAL_WIDTH_INTO_HEADER_PROFILE_FOR_PLATES..... | 213 |
| 5.168 | XS_DSTV_USE_COUNTERSUNK_HOLES..... | 213 |
| 5.169 | XS_DSTV_USE_EQUAL_ACCURACY_FOR_PLATE_PROFILE_AND_WIDTH..... | 214 |
| 5.170 | XS_DSTV_USE_ONE_VERTEX_SHARP_INNER_CORNER | 214 |
| 5.171 | XS_DSTV_USE_REAL_DIMENSIONS_IN_HEADER..... | 215 |
| 5.172 | XS_DSTV_WRITE_BEHIND_FACE_FOR_PLATE | 215 |
| 5.173 | XS_DUPLICATE_CHECK_LIMIT_FOR_COPY_AND_MOVE..... | 215 |
| 5.174 | XS_DWG_EXPORT_UPDATE_TS_LINEWORK_OPTION | 216 |
| 5.175 | XS_DWG_IMPORT_IGNORE_UNITS | 216 |
| 5.176 | XS_DXF_FONT_CONVERSION_FILE..... | 217 |
| 5.177 | XS_DXF_FONT_NAME | 218 |
| 5.178 | XS_DXF_TEXT_HEIGHT_FACTOR | 218 |
| 5.179 | XS_DXF_TEXT_WIDTH_FACTOR | 218 |
| 5.180 | DXK_FONTPATH | 219 |

| | | |
|----------|---|------------|
| 5.181 | DXK_SYMBOLPATH | 219 |
| 6 | Advanced options - E..... | 221 |
| 6.1 | XS_ENABLE_FAST_CUSTOM_PROPERTY_LOADING..... | 221 |
| 6.2 | XS_ENABLE_INNER_CONTOURS_IN_CUT_PARTS | 221 |
| 6.3 | XS_ENABLE_MIDDLE_BUTTON_DOUBLE_CLICK_ZOOM_ORIGINAL..... | 222 |
| 6.4 | XS_ENABLE_PHASE_OPTION_IN_NUMBERING..... | 222 |
| 6.5 | XS_ENABLE_POUR_MANAGEMENT..... | 224 |
| 6.6 | XS_ENABLE_PRECAST_CONTINUOUS_CONCRETE..... | 224 |
| 6.7 | XS_ENABLE_PULLOUT_PLACEHOLDERS | 225 |
| 6.8 | XS_ENTER_FINALIZES_COMMANDS..... | 226 |
| 6.9 | XS_ENABLE_OVERLAPPING_CUT_LINE_REMOVAL..... | 226 |
| 6.10 | XS_ENABLE_REBAR_MARK_LEADER_LINE_BASE_POINT_OPTIMIZATION... | 227 |
| 6.11 | XS_EQUAL_SHAPE_DIMENSIONS_TO_BOTH_ENDS_LIMIT | 227 |
| 6.12 | XS_ERASE_UDA_VALUE_WITH_ATTRIBUTE_IMPORT_NULL_AND_BLANK... | 228 |
| 6.13 | XS_EXCLUDED_PARTS_IN_ORIENTATIONAL_NUMBERING..... | 229 |
| 6.14 | XS_EXPORT_BREP_AS_EXACT_SOLID..... | 229 |
| 6.15 | XS_EXPORT_CODEPAGE..... | 230 |
| 6.16 | XS_EXPORT_DGN_COORDINATE_SCALE | 231 |
| 6.17 | XS_EXPORT_DGN_FILENAME | 232 |
| 6.18 | XS_EXPORT_DGN_INCLUDE_CUTS | 232 |
| 6.19 | XS_EXPORT_DGN_INCLUDE_INNER_CONTOUR | 233 |
| 6.20 | XS_EXPORT_DGN_ROUND_SEGMENTS | 233 |
| 6.21 | XS_EXPORT_DGN_USE_CLASS_AS_COLOR | 233 |
| 6.22 | XS_EXPORT_DGN_USE_VOLUMETRIC | 234 |
| 6.23 | XS_EXPORT_DRAWING_TRY_TO_KEEP_LOCATION..... | 234 |
| 6.24 | XS_EXPORT_FILLMODE..... | 234 |
| 6.25 | XS_EXPORT_IFC_REBARSET_INDIVIDUAL_BARS..... | 235 |
| 6.26 | XS_EXPORT_LINE_TYPE_DEFINITION_FILE..... | 236 |
| 6.27 | XS_EXPORT_STEEL2000_PRIMARY_IDS | 236 |
| 6.28 | XS_EXTENSION_DIRECTORY..... | 236 |
| 6.29 | XS_EXTERNAL_EXCEL_DESIGN_PATH | 236 |
| 7 | Advanced options - F..... | 238 |
| 7.1 | XS_FILTER_SEPARATOR_CHAR | 238 |
| 7.2 | XS_FIRM | 238 |
| 7.3 | XS_FIX_FRAME_OF_FIXED_MODELVIEW..... | 239 |
| 7.4 | XS_FLAT_PREFIX | 239 |
| 7.5 | XS_FLAT_THICKNESS_TOLERANCE | 240 |
| 7.6 | XS_FLAT_TOLERANCE | 240 |
| 7.7 | FLEXLM_TIMEOUT..... | 240 |

| | | |
|-----------|--|------------|
| 7.8 | XS_FRACTION_HEIGHT_FACTOR | 241 |
| 7.9 | XS_FS_POSTFIX_FOR_MERGED_PART_MARK | 241 |
| 8 | Advanced options - G..... | 242 |
| 8.1 | XS_GA_CONNECTING_SIDE_MARK_SYMBOL..... | 242 |
| 8.2 | XS_GA_DRAWING_VIEW_TITLE | 242 |
| 8.3 | XS_GAGE_OF_OUTSTANDING_LEG_STRING | 243 |
| 8.4 | XS_GA_HIDDEN_NORTH_MARK_SYMBOL | 243 |
| 8.5 | XS_GA_NORTH_MARK_SCALE | 244 |
| 8.6 | XS_GA_NORTH_MARK_SYMBOL | 244 |
| 8.7 | XS_GA_OMITTED_DIAMETER_TYPE | 244 |
| 8.8 | XS_GET_ASSEMBLY_LEVELS_FROM_ASSEMBLY_MAIN_PART..... | 245 |
| 8.9 | XS_GET_CAST_UNIT_LEVELS_FROM_CAST_UNIT_MAIN_PART..... | 245 |
| 8.10 | XS_GOL_SYMMETRY_DISTANCE..... | 245 |
| 8.11 | XS_GRID_DIMENSION_OVERALL_LENGTH | 246 |
| 8.12 | XS_GRID_COLOR_FOR_WORK_PLANE | 246 |
| 8.13 | XS_GRID_PLANES_VISIBLE_WITH_USERPLANES..... | 246 |
| 8.14 | XS_GRID_TEXT_FONT | 247 |
| 9 | Advanced options - H..... | 248 |
| 9.1 | XS_HANDLE_SCALE | 248 |
| 9.2 | XS_HATCH_PATTERN_LINE_LIMIT | 248 |
| 9.3 | XS_HATCH_SCALE_LIMIT..... | 249 |
| 9.4 | XS_HATCH_SEGMENT_BUFFER_SIZE | 249 |
| 9.5 | XS_HATCH_SPECIAL_COLOR_ACI..... | 249 |
| 9.6 | XS_HATCH_SPECIAL_COLOR_R | 250 |
| 9.7 | XS_HATCH_SPECIAL_COLOR_G | 250 |
| 9.8 | XS_HATCH_SPECIAL_COLOR_B | 250 |
| 9.9 | XS_HELP_PATH..... | 251 |
| 9.10 | XS_HIDDEN_LINES_CHECK_TOLERANCE | 251 |
| 9.11 | XS_HIDDEN_LINES_UNHIDE_EMBEDDED..... | 251 |
| 9.12 | XS_HIDDEN_NORTH_MARK_SYMBOL | 253 |
| 9.13 | XS_HIDDEN_REMOVE_DOUBLE_LINES | 254 |
| 9.14 | XS_HIDDEN_USE_BOLT_PLANES | 254 |
| 9.15 | XS_HIDE_OTHER_PARTS_IN_ASSEMBLY_AND_CAST_UNIT_VIEWS..... | 256 |
| 9.16 | XS_HIDE_WORKAREA..... | 257 |
| 9.17 | XS_HIGHLIGHT_ASSOCIATIVE_DIMENSION_CHANGES | 258 |
| 9.18 | XS_HIGHLIGHT_MARK_CONTENT_CHANGES | 258 |
| 9.19 | XS_HOLE_MARK_STRING_FOR_SIZE | 259 |
| 9.20 | XS_HOLE_MARK_STRING_FOR_SIZE_IN_GA | 260 |
| 10 | Advanced options - I..... | 262 |

| | | |
|-----------|---|------------|
| 10.1 | XS_IGNORE_CUT_VALUE_IN_TEMPLATE..... | 262 |
| 10.2 | XS_IGNORE_CROSSBAR_LOCATION_IN_REBAR_MESH_NUMBERING..... | 262 |
| 10.3 | XS_IGNORE_SUBASSEMBLY_HIERARCHY_IN_DIMENSIONING..... | 263 |
| 10.4 | XS_IFC_EXPORT_OBJECT_LAYER_FROM_UDA..... | 263 |
| 10.5 | XS_IFC2X3_EXPORT_SECONDARY_AS_DISCRETEACCESSORY..... | 264 |
| 10.6 | XS_IMPERIAL | 264 |
| 10.7 | XS_IMPERIAL_DATE | 264 |
| 10.8 | XS_IMPERIAL_INPUT | 265 |
| 10.9 | XS_IMPERIAL_TIME | 265 |
| 10.10 | XS_IMPERIAL_TRIANGLES | 265 |
| 10.11 | XS_IMPORT_DWG_TEXT_AS_POLYGON | 266 |
| 10.12 | XS_IMPORT_MODEL_LOG | 266 |
| 10.13 | XS_INCH_SIGN_ALWAYS | 266 |
| 10.14 | XS_INCLUDE_DWG_ATTRIBUTES_IN_REPORTS_AND_INQUIRE..... | 267 |
| 10.15 | XS_INHERIT_CONCRETE_PART_NUMBERING_SETTINGS_FROM_ CAST_UNIT..... | 267 |
| 10.16 | XS_INP | 267 |
| 10.17 | XS_INTELLIGENCE_DO_NOT_REMOVE_OBSOLETE_VIEWS | 268 |
| 10.18 | XS_INTELLIGENCE_DO_NOT_REMOVE_OBSOLETE_VIEWS_IN_GA | 268 |
| 10.19 | XS_INTELLIGENCE_MAX_PART_COUNT..... | 269 |
| 10.20 | XS_INTELLIGENCE_MAX_PLANE_COUNT..... | 269 |
| 10.21 | XS_INTELLIGENCE_MAX_RULE_COUNT..... | 269 |
| 10.22 | XS_INTELLIGENT_CLONING_ADD_DIMENSIONS..... | 270 |
| 10.23 | XS_INTELLIGENT_DRAWING_ALLOWED | 270 |
| 10.24 | XS_INTELLIGENT_DRAWING_ALLOWED_IN_GA | 271 |
| 10.25 | XS_INTELLIGENT_MESSAGES_ALLOWED | 271 |
| 10.26 | XS_INTELLIGENT_UPDATE_ADD_DIMENSIONS..... | 271 |
| 10.27 | XS_INVALID_POUR_BREAK_COLOR..... | 272 |
| 10.28 | XS_I_PROFILE_CENTER | 272 |
| 10.29 | XS_ISO_LEG_LENGTH_AS_WELDSIZE..... | 272 |
| 11 | Advanced options - J..... | 274 |
| 11.1 | XS_JOINT_NUMBER_FORMAT | 274 |
| 11.2 | XS_JOINTS_USE_NOTCH1 | 274 |
| 12 | Advanced options - K..... | 276 |
| 12.1 | XS_KEEP_AUTOSAVE_FILES_ON_EXIT_WHEN_NOT_SAVING | 276 |
| 12.2 | XS_KEYIN_ABSOLUTE_PREFIX | 276 |
| 12.3 | XS_KEYIN_DEFAULT_MODE..... | 277 |
| 12.4 | XS_KEYIN_GLOBAL_PREFIX | 277 |
| 12.5 | XS_KEYIN_RELATIVE_PREFIX | 278 |
| 12.6 | XS_KNOCK_OFF_DIMENSION_PRECISION..... | 278 |

| | | |
|-----------|---|------------|
| 13 | Advanced options - L | 279 |
| 13.1 | XS_LANGUAGE..... | 279 |
| 13.2 | XS_LEADER_LINE_TO_DRAGGED_DIMENSION_TEXT..... | 279 |
| 13.3 | XS_LICENSE_SERVER_HOST..... | 280 |
| 13.4 | XS_LOAD_MODELING_CODE..... | 280 |
| 13.5 | XS_LOG_FILE_NAME | 281 |
| 13.6 | XS_LOG_LEVEL..... | 281 |
| 13.7 | XS_LOG_TIMER..... | 281 |
| 13.8 | XS_LOGPATH | 282 |
| 13.9 | XS_LONGHOLE_MARK_STRING_FOR_SIZE | 282 |
| 13.10 | XS_LONGHOLE_MARK_STRING_FOR_SIZE_IN_GA | 283 |
| 14 | Advanced options - M | 285 |
| 14.1 | XS_MACRO_DIRECTORY | 285 |
| 14.2 | XS_MACRO_ENABLE_TIMESTAMP | 286 |
| 14.3 | XS_MACRO_LOG | 286 |
| 14.4 | XS_MACRO_REFERENCES | 286 |
| 14.5 | XS_MAGNETIC_PLANE_OFFSET..... | 287 |
| 14.6 | XS_MARK_ALL_BOLT_GROUPS_SEPARATELY | 287 |
| 14.7 | XS_MARK_ELEMENT_SPACE_FACTOR | 288 |
| 14.8 | XS_MARK_FONT | 289 |
| 14.9 | XS_MARK_INTELLIGENT_PLACING..... | 289 |
| 14.10 | XS_MARK_INTELLIGENT_POST_FREEPLACE_NEARBY..... | 290 |
| 14.11 | XS_MARK_LEADER_LINE_ARROW_HEIGHT | 290 |
| 14.12 | XS_MARK_LEADER_LINE_ARROW_LENGTH | 291 |
| 14.13 | XS_MARK_LEADER_LINE_EXTENSION_LENGTH | 291 |
| 14.14 | XS_MARK_LEADER_LINE_LENGTH_FOR_PERPENDICULAR..... | 291 |
| 14.15 | XS_MARK_LEADER_LINE_POSITION_TYPE_FOR_NO_FRAME | 292 |
| 14.16 | XS_MARK_LEADER_LINE_POSITION_TYPE_FOR_RECTANGULAR_FRAME ... | 294 |
| 14.17 | XS_MARK_LINE_SPACE_FACTOR | 295 |
| 14.18 | XS_MARK_PLACING_ANGLE_CLOSE_TO_45_DEGREES..... | 296 |
| 14.19 | XS_MARK_TEXT_FRAME_BOX_HEIGHT_FACTOR | 296 |
| 14.20 | XS_MATERIAL_SYMBOL_REPRESENTATION_FILE | 297 |
| 14.21 | XS_MAX_ANGLE_BETWEEN_SKEWED_END_PLATE_AND_BEAM_END | 297 |
| 14.22 | XS_MAX_ANGLE_TOLERANCE_BETWEEN_COMPLEX_MAIN_PARTS | 298 |
| 14.23 | XS_MAX_AUTOMATIC_RADIUS_DIMENSION | 298 |
| 14.24 | XS_MAX_DECIMALS_IN_PROFILE_NAME | 298 |
| 14.25 | XS_MAX_DEVIATION_FOR_CURVED_PART_EDGES..... | 299 |
| 14.26 | XS_MAX_FRACTIONS_IN_MODEL_DIMENSION | 299 |
| 14.27 | XS_MAXIMUM_NUMBER_OF_PLANES_TO_NAME..... | 300 |

| | | |
|-----------|--|------------|
| 14.28 | XS_MAX_MERGE_DISTANCE_IN_HORIZONTAL | 300 |
| 14.29 | XS_MAX_MERGE_DISTANCE_IN_VERTICAL | 300 |
| 14.30 | XS_MAX_SPACE_BETWEEN_COMPLEX_ASSEMBLY_PARALLEL_PARTS | 301 |
| 14.31 | XS_MDIBASICVIEWPARENT | 301 |
| 14.32 | XS_MDIVIEWPARENT | 302 |
| 14.33 | XS_MDIZOOMPARENT | 302 |
| 14.34 | XS_MESSAGES | 303 |
| 14.35 | XS_MESSAGES_PATH..... | 303 |
| 14.36 | XS_MESSAGES_PATH_INTERNAL..... | 303 |
| 14.37 | XS_MIN_DISTANCE_FOR_CONNECTING_SIDE_MARK..... | 304 |
| 14.38 | XS_MIN_MERGE_PART_COUNT | 305 |
| 14.39 | XS_MIN_NUMBER_OF_ASSEMBLY_MULTI_CHARACTERS | 305 |
| 14.40 | XS_MIN_NUMBER_OF_PART_MULTI_CHARACTERS | 305 |
| 14.41 | XS_MIN_WELD_LINE_LENGTH..... | 306 |
| 14.42 | XS_MIS_FILE_DIRECTORY | 306 |
| 14.43 | XS_MIS_SEQUENCE..... | 306 |
| 14.44 | XS_MODEL_BACKUP_DIRECTORY..... | 307 |
| 14.45 | XS_MODEL_IMPORT_LOCK_OBJECTS..... | 308 |
| 14.46 | XS_MODEL_PREFIX_INFLUENCES_MULTI_NUMBERING_FOR | 308 |
| 14.47 | XS_MODEL_TEMPLATE_DIRECTORY..... | 309 |
| 14.48 | XS_MULTIDRAWING_KEEP_OBSOLETE_DRAWINGS..... | 309 |
| 14.49 | XS_MULTIDRAWING_REMOVE_VIEW_LABEL_GAP | 309 |
| 14.50 | XS_MULTI_DRAWING_VIEW_PLACING_TRIAL_NUMBER..... | 310 |
| 14.51 | XS_MULTI_DRAWING_VIEW_TITLE..... | 310 |
| 14.52 | XS_MULTI_NUMBERING_INCLUDE_ASSEMBLY_PARTS..... | 310 |
| 14.53 | XS_MULTIMPLIER_SEPARATOR_FOR_MERGED_PART_MARK | 311 |
| 14.54 | XS_MULTIUUSER_SAVE_REOPEN_DISABLE_COMPACTON..... | 311 |
| 15 | Advanced options - N..... | 312 |
| 15.1 | XS_NEIGHBOUR_PART_SKEW_LIMIT | 312 |
| 15.2 | XS_NO_AUTO_DISPLAY_VIEWS | 312 |
| 15.3 | XS_NO_BOLT_ANGLE_DIMENSIONS | 313 |
| 15.4 | XS_NO_CHAMFERS_IN_EXACT_MODE | 313 |
| 15.5 | XS_NO_END_VIEWS_TO_INCLUDED_SINGLE_DRAWINGS | 313 |
| 15.6 | XS_NO_RELATIVE_SHAPE_DIMENSIONS | 314 |
| 15.7 | XS_NO_UNFOLDING_LINES_TO_DRAWINGS..... | 314 |
| 15.8 | XS_NO_SINGLE_PART_DRAWINGS_FOR | 314 |
| 15.9 | XS_NORTH_MARK_SCALE | 315 |
| 15.10 | XS_NORTH_MARK_SYMBOL | 315 |
| 15.11 | XS_NSFS_POSTFIX_FOR_MERGED_PART_MARK | 315 |
| 15.12 | XS_NSFS_TEXT_POSITION_IN_PART_MARK | 316 |

| | | |
|-----------|---|------------|
| 15.13 | XS_NS_POSTFIX_FOR_MERGED_PART_MARK | 317 |
| 15.14 | XS_NUMBERING_RESULTS_DIALOG_DISPLAY_TIME | 318 |
| 16 | Advanced options - O | 319 |
| 16.1 | XS_OBJECT_SELECTION_CONFIRMATION | 319 |
| 16.2 | XS_OBJECTLOCK_DEFAULT | 319 |
| 16.3 | XS_OMIT_MARKS_OF_HIDDEN_PARTS_IN_GA_DRAWINGS | 320 |
| 16.4 | XS_OMIT_MARKS_OF_PARTS_OUT_OF_VIEW_PLANE_LIMIT_ANGLE | 320 |
| 16.5 | XS_OMITTED_BOLT_ASSEMBLY_TYPE | 320 |
| 16.6 | XS_OMITTED_BOLT_TYPE | 321 |
| 16.7 | XS_OMITTED_DIAMETER_TYPE | 321 |
| 16.8 | XS_OMITTED_PART_NAME_IN_AUTOCONNECTION | 322 |
| 16.9 | XS_OMITTED_WELD_TYPE | 322 |
| 16.10 | XS_OPEN_DRAWINGS_MAXIMIZED | 323 |
| 16.11 | XS_ORIENTATION_MARK_DIRECTION | 323 |
| 16.12 | XS_ORIENTATION_MARK_MOVE_DIST_FOR_BEAMS | 324 |
| 16.13 | XS_ORIENTATION_MARK_MOVE_DIST_FOR_BEAMS_IN_GA | 324 |
| 16.14 | XS_ORIENTATION_MARK_MOVE_DIST_FOR_COLUMNS | 324 |
| 16.15 | XS_ORIENTATION_MARK_MOVE_DIST_FOR_COLUMNS_IN_GA | 325 |
| 17 | Advanced options - P | 326 |
| 17.1 | XS_PARAMETRIC_PROFILE_SEPARATOR | 326 |
| 17.2 | XS_PART_DIMENSION_PLANES_TABLE | 327 |
| 17.3 | XS_PART_MERGE_MAX_DISTANCE | 327 |
| 17.4 | XS_PART_MULTI_NUMBER_FORMAT_STRING | 327 |
| 17.5 | XS_PART_POSITION_NUMBER_FORMAT_STRING | 328 |
| 17.6 | XS_PART_POSITION_TO_EDGE_NEAREST_TO_NEIGHBOUR | 329 |
| 17.7 | XS_PART_POSITION_TO_LEADING_EDGE | 330 |
| 17.8 | XS_PART_POSITION_TO_LEADING_EDGE_IN_COLUMNS_ALSO | 331 |
| 17.9 | XS_PIXEL_TOLERANCE | 331 |
| 17.10 | XS_PLATE_ROUNDING_DECIMALS | 331 |
| 17.11 | XS_PLOT_ORIGIN_MOVE_X | 332 |
| 17.12 | XS_PLOT_ORIGIN_MOVE_Y | 332 |
| 17.13 | XS_PLOT_VIEW_FRAMES | 333 |
| 17.14 | PML_ASSEMBLY_MARKS_IN_USE | 333 |
| 17.15 | PML_CARDINAL_POINT_NOT_IN_USE | 333 |
| 17.16 | XS_PML_EXPORT_INCLUDE_GLOBAL_ID | 334 |
| 17.17 | XS_PML_EXPORT_USE_ADDITIONAL_CUT_DIST | 334 |
| 17.18 | XS_POINT_CLOUD_CACHE_FOLDER | 334 |
| 17.19 | XS_POINT_CLOUDS_WEB_CACHE | 335 |
| 17.20 | XS_POLYBEAM_CHORD_TOLERANCE | 335 |

| | | |
|-----------|---|------------|
| 17.21 | XS_POLYBEAM_MAX_ANGLE_BETWEEN_CS..... | 335 |
| 17.22 | XS_POLYBEAM_CURVATURE_TOLERANCE..... | 336 |
| 17.23 | XS_POLYGON_CUT_EXTRA_THICKNESS | 336 |
| 17.24 | XS_POLYGON_PERPENDICULAR_EDGE_PREFERENCE_FACTOR | 337 |
| 17.25 | XS_POLYGON_SQUARE_CORNER_PREFERENCE_FACTOR | 339 |
| 17.26 | XS_POP_MARK_COLOR..... | 341 |
| 17.27 | XS_POP_MARK_HEIGHT..... | 341 |
| 17.28 | XS_POP_MARK_SYMBOL..... | 342 |
| 17.29 | XS_POSITION_DIMENSIONS_FOR_HOLES _IN_SINGLE_SECONDARY_PARTS_IN_ASSEMBLY_DRAWING..... | 342 |
| 17.30 | XS_POUR_BREAK_COLOR..... | 342 |
| 17.31 | XS_POUR_BREAK_SYMBOL..... | 343 |
| 17.32 | XS_POUR_OBJECT_COLOR..... | 344 |
| 17.33 | XS_PREVIEW_LIMIT..... | 344 |
| 17.34 | XS_PRINT_MULTISHEET_BORDER | 344 |
| 17.35 | XS_PRINT_REPORT_FONT | 345 |
| 17.36 | XS_PRINT_REPORT_LINE_WIDTH_LANDSCAPE | 345 |
| 17.37 | XS_PRINT_REPORT_LINE_WIDTH_PORTRAIT | 345 |
| 17.38 | XS_PRINT_REPORT_PAGE_HEIGHT_LANDSCAPE | 346 |
| 17.39 | XS_PRINT_REPORT_PAGE_HEIGHT_PORTRAIT | 346 |
| 17.40 | XS_PRODUCT_IDENTIFIER..... | 347 |
| 17.41 | XS_PROFDB | 347 |
| 17.42 | XS_PROFILE_ANALYSIS_CHECK_ALL | 348 |
| 17.43 | XS_PROFILE_ANALYSIS_VALUE_DIFF_LIMIT | 348 |
| 17.44 | XS_PROFILE_DISPLAY_INCH_MARK_AFTER_FRACTIONS_IN_REPORTS | 349 |
| 17.45 | XS_PROJECT | 349 |
| 17.46 | XS_PROTECT_SYMBOLS | 350 |
| 18 | Advanced options - R..... | 351 |
| 18.1 | XS_RADIUS_TEXT_IN_UNFOLDING_BENDING_LINE_DIMENSIONING | 351 |
| 18.2 | XSR_BOLT_LENGTH_USE_ONLY_INCHES | 351 |
| 18.3 | XS_REBAR_BEND_MARK_SYMBOL_MIN_SIZE | 352 |
| 18.4 | XS_REBAR_DIMENSION_LINE_SYMBOL..... | 353 |
| 18.5 | XS_REBAR_END_SYMBOL_MIN_SIZE | 353 |
| 18.6 | XS_REBAR_GEOMETRY_TYPE_IN_NUMBERING..... | 354 |
| 18.7 | XS_REBAR_MARK_LEADER_LINE_BASE_POINT_SEARCH_STEP_LENGTH | 355 |
| 18.8 | XS_REBAR_MARK_LEADER_LINE_BASE_POINT_SEARCH_TOLERANCE | 356 |
| 18.9 | XS_REBAR_POSITION_NUMBER_FORMAT_STRING..... | 356 |
| 18.10 | XS_REBAR_PULLOUT_ANGLE_TEXT_FRAME | 357 |
| 18.11 | XS_REBAR_PULLOUT_ANGLE_TEXT_UNDERLINE..... | 357 |
| 18.12 | XS_REBAR_RECOGNITION_CURVE_TOLERANCE..... | 358 |

| | | |
|-------|---|------------|
| 18.13 | XS_REBAR_RECOGNITION_EXTRA_POINT_SHORTENING..... | 358 |
| 18.14 | XS_REBAR_RECOGNITION_HOOKS_CONSIDERATION..... | 359 |
| 18.15 | XS_REBAR_RECOGNITION_MAXCURVE..... | 359 |
| 18.16 | XS_REBAR_REVERSE_END_SYMBOLS | 360 |
| 18.17 | XS_REBARSET_BUFFER_SIZE..... | 361 |
| 18.18 | XS_REBARSET_COLOR_BARGROUPS..... | 362 |
| 18.19 | XS_REBARSET_CREATION_ANGLE_TOLERANCE_FOR_CROSSING_REBARS.. | 362 |
| 18.20 | XS_REBARSET_CREATION_ANGLE_TOLERANCE_FOR_ LONGITUDINAL_REBARS..... | 363 |
| 18.21 | XS_REBARSET_ENABLE_BAR_GROUPING_WHEN_SPACING_DIFFERS..... | 363 |
| 18.22 | XS_REBARSET_LEG_CONNECTION_TOLERANCE..... | 364 |
| 18.23 | XS_REBARSET_MINIMUM_BENDING_ANGLE..... | 364 |
| 18.24 | XS_REBARSET_MINIMUM_LEG_DEVIATION..... | 364 |
| 18.25 | XS_REBARSET_REBAR_LAYER_FORMAT_STRING..... | 365 |
| 18.26 | XS_REBARSET_ROUNDING_TOLERANCE..... | 365 |
| 18.27 | XS_REBARSET_SHOW_END_DETAIL_MODIFIERS..... | 366 |
| 18.28 | XS_REBARSET_SHOW_GUIDELINES..... | 367 |
| 18.29 | XS_REBARSET_SHOW_LEGFACES..... | 367 |
| 18.30 | XS_REBARSET_SHOW_MODIFIERS_CREATED_BY_COMPONENTS..... | 368 |
| 18.31 | XS_REBARSET_SHOW_PROPERTY_MODIFIERS..... | 368 |
| 18.32 | XS_REBARSET_SHOW_SPLITTERS..... | 369 |
| 18.33 | XS_REBARSET_SIMILAR_GROUPING_NUMBER..... | 369 |
| 18.34 | XS_REBARSET_SIMILAR_GROUPING_TOLERANCE..... | 370 |
| 18.35 | XS_REBARSET_TAPERED_CURVED_GROUPING_TOLERANCE..... | 370 |
| 18.36 | XS_REBARSET_TAPERED_GROUP_POSITION_NUMBER_FORMAT_STRING.. | 371 |
| 18.37 | XS_REBARSET_TAPERED_LINEAR_GROUPING_TOLERANCE..... | 372 |
| 18.38 | XS_REBARSET_TAPERED_REBAR_POSITION_NUMBER_FORMAT_STRING.. | 373 |
| 18.39 | XS_REBARSET_USE_GROUP_NUMBER_FOR_BARS_IN_TAPERED_GROUPS.. | 374 |
| 18.40 | XS_REBAR_USE_ALWAYS_METHOD_A_FOR_90_DEGREE_HOOK_ DIMENSIONS | 375 |
| 18.41 | XS_RECREATE_MARKS_IN_INTELLIGENT_CLONING..... | 375 |
| 18.42 | XS_RECREATE_UNMODIFIED_DRAWINGS | 375 |
| 18.43 | XS_REFERENCE_CACHE..... | 376 |
| 18.44 | XS_REFERENCE_MODEL_KEEP_VERSIONS_COUNT..... | 376 |
| 18.45 | XS_REFERENCE_USE_RENDERED_CLIPPING | 377 |
| 18.46 | XS_REFRESH_ALSO_LOCKED_REFERENCE_MODELS..... | 378 |
| 18.47 | XS_REMEMBER_LAST_PLOT_DIALOG_VALUES..... | 378 |
| 18.48 | XS_REMOVE_VOID_FROM_BOLT_MATERIAL_THICKNESS..... | 378 |
| 18.49 | XS_RENDERED_CURSOR_LINE_WIDTH | 379 |
| 18.50 | XS_RENDERED_FIELD_OF_VIEW..... | 380 |
| 18.51 | XS_RENDERED_GL_FOG_END_VALUE..... | 381 |

| | | |
|-----------|---|------------|
| 18.52 | XS_RENDERED_GL_FOG_START_VALUE..... | 381 |
| 18.53 | XS_RENDERED_PIXEL_TOLERANCE_SCALE | 382 |
| 18.54 | XS_REPORT_BOLTS_WITH_SUPPORTING_MEMBER | 382 |
| 18.55 | XS_REPORT_OUTPUT_DIRECTORY | 384 |
| 18.56 | XS_RESTORE_ENABLES..... | 385 |
| 18.57 | XS_RIBBON_CONFIGURATION_CARBON..... | 385 |
| 18.58 | XS_RIBBON_CONFIGURATION_DIAMOND..... | 385 |
| 18.59 | XS_RIBBON_CONFIGURATION_GRAPHITE..... | 386 |
| 18.60 | XS_ROTATE_CUT_VIEWS | 387 |
| 18.61 | XS_RUN_AT_STARTUP..... | 388 |
| 18.62 | XS_RUNPATH | 389 |
| 18.63 | XSR_USE_NO_FEET_SEPARATOR | 389 |
| 18.64 | XSR_USE_NO_FEET_SYMBOL | 389 |
| 18.65 | XSR_USE_NO_INCH_SYMBOL | 390 |
| 18.66 | XSR_USE_ZERO_FEET_VALUE | 390 |
| 18.67 | XSR_USE_ZERO_INCH_FOR_FRACTIONS | 391 |
| 18.68 | XSR_USE_ZERO_INCH_VALUE | 391 |
| 19 | Advanced options - S..... | 392 |
| 19.1 | XS_SAVE_WITH_COMMENT..... | 392 |
| 19.2 | XS_SCALE_COPIED_OR_MOVED_OBJECTS_IN_DRAWINGS | 392 |
| 19.3 | XS_SCALE_MARKS_TO_FIT_LIMIT | 393 |
| 19.4 | XS_SCREW_DIAMOND_WITHOUT_PHI | 393 |
| 19.5 | XS_SDNF_CONVERT_PL_PROFILE_TO_PLATE | 393 |
| 19.6 | XS_SDNF_EXPORT_INCLUDE_GLOBAL_ID | 394 |
| 19.7 | XS_SDNF_IMPORT_MIRROR_SWAP_OFFSETS..... | 394 |
| 19.8 | XS_SDNF_IMPORT_STORE_MEMBER_NUMBER | 394 |
| 19.9 | XS_SECONDARY_PART_HARDSTAMP | 395 |
| 19.10 | XS_SECTION_LINE_COLOR | 395 |
| 19.11 | XS_SECTION_SYMBOL_LEFT_ARROW_SYMBOL | 397 |
| 19.12 | XS_SECTION_SYMBOL_REFERENCE | 398 |
| 19.13 | XS_SECTION_SYMBOL_RIGHT_ARROW_SYMBOL | 399 |
| 19.14 | XS_SECTION_VIEW_REFERENCE | 400 |
| 19.15 | XS_SET_FIXEDMAINVIEW_UDA_TO_AFFECT_NUMBERING..... | 401 |
| 19.16 | XS_SET_HATCH_ORIGIN_INTO_VIEW_ORIGIN..... | 402 |
| 19.17 | XS_SET_MAX_POINT_CLOUD_POINT_COUNT..... | 402 |
| 19.18 | XS_SHARING_INFO_URL..... | 403 |
| 19.19 | XS_SHARING_JOIN_SHOW_AVAILABLE_VERSIONS..... | 403 |
| 19.20 | XS_SHARING_READIN_SHOW_AVAILABLE_VERSIONS..... | 404 |
| 19.21 | XS_SHARING_READIN_SHOW_CHANGEMANAGER..... | 404 |
| 19.22 | XS_SHARING_READIN_SHOW_CHANGEMANAGER_CONFLICTSONLY..... | 405 |

| | | |
|-------|--|-----|
| 19.23 | XS_SHARING_TEMP..... | 405 |
| 19.24 | XS_SHOP_BOLT_MARK_STRING_FOR_SIZE | 405 |
| 19.25 | XS_SHOP_BOLT_MARK_STRING_FOR_SIZE_IN_GA | 406 |
| 19.26 | XS_SHOP_HOLE_MARK_STRING_FOR_SIZE | 408 |
| 19.27 | XS_SHOP_HOLE_MARK_STRING_FOR_SIZE_IN_GA | 409 |
| 19.28 | XS_SHOP_LONGHOLE_MARK_STRING_FOR_SIZE | 410 |
| 19.29 | XS_SHOP_LONGHOLE_MARK_STRING_FOR_SIZE_IN_GA | 411 |
| 19.30 | XS_SHOP_OVERSIZEDHOLE_MARK_STRING_FOR_SIZE..... | 412 |
| 19.31 | XS_SHOP_OVERSIZEDHOLE_MARK_STRING_FOR_SIZE_IN_GA..... | 413 |
| 19.32 | XS_SHOP_TAPPEDHOLE_MARK_STRING_FOR_SIZE..... | 414 |
| 19.33 | XS_SHOP_TAPPEDHOLE_MARK_STRING_FOR_SIZE_IN_GA..... | 415 |
| 19.34 | XS_SHORTENING_SYMBOL_COLOR..... | 416 |
| 19.35 | XS_SHORTENING_SYMBOL_LINE_TYPE..... | 417 |
| 19.36 | XS_SHORTENING_SYMBOL_WITH_ZIGZAG..... | 417 |
| 19.37 | XS_SHOW_HARDWARE_DASHED_LINE_IN_PIXEL_SCALE..... | 418 |
| 19.38 | XSR_SHOW_INCH_MARK_IN_PROFILE_NAMES | 419 |
| 19.39 | XS_SHOW_NOTIFICATION_REPORT..... | 419 |
| 19.40 | XS_SHOW_PERFORM_NUMBERING_MESSAGE..... | 420 |
| 19.41 | XS_SHOW_PROGRESS_BAR_FOR_PROJECT_STATUS_VISUALIZATION..... | 420 |
| 19.42 | XS_SHOW_REVISION_MARK_ON_DRAWING_LIST | 421 |
| 19.43 | XS_SHOW_SHADOW_FOR_ORTHO_IN_DX..... | 421 |
| 19.44 | XS_SHOW_SHADOW_FOR_PERSPECTIVE_IN_DX..... | 421 |
| 19.45 | XS_SHOW_SITE_STUDS_IN_ASSEMBLY_DRAWINGS | 422 |
| 19.46 | XS_SHOW_STATISTICS_IN_DX | 422 |
| 19.47 | XS_SHOW_STUDS_IN_WORKSHOP_DRAWINGS | 422 |
| 19.48 | XS_SHOW_TEMPLATE_LOG_MESSAGES | 423 |
| 19.49 | XS_SINGLE_CENTERED_SCREW | 423 |
| 19.50 | XS_SINGLE_CLOSE_DIMENSIONS | 423 |
| 19.51 | XS_SINGLE_CLOSE_SHORT_DIMENSIONS | 424 |
| 19.52 | XS_SINGLE_COMBINE_DISTANCE | 424 |
| 19.53 | XS_SINGLE_COMBINE_MIN_DISTANCE | 424 |
| 19.54 | XS_SINGLE_COMBINE_WAY | 425 |
| 19.55 | XS_SINGLE_DIMENSION_TYPE | 425 |
| 19.56 | XS_SINGLE_DRAW_PART_AS | 426 |
| 19.57 | XS_SINGLE_EXCLUDE | 426 |
| 19.58 | XS_SINGLE_FORWARD_OFFSET | 427 |
| 19.59 | XS_SINGLE_NO_RELATIVE_SHAPE_DIMENSIONS | 427 |
| 19.60 | XS_SINGLE_NO_SHORTEN | 428 |
| 19.61 | XS_SINGLE_ORIENTATION_MARK | 428 |
| 19.62 | XS_SINGLE_PART_DRAWING_VIEW_TITLE | 428 |
| 19.63 | XS_SINGLE_PART_EXTREMA | 429 |

| | | |
|-----------|---|------------|
| 19.64 | XS_SINGLE_PART_SHAPE | 429 |
| 19.65 | XS_SINGLE_SCALE..... | 430 |
| 19.66 | XS_SINGLE_SCREW_INTERNAL | 430 |
| 19.67 | XS_SINGLE_SCREW_POSITIONS | 430 |
| 19.68 | XS_SINGLE_USE_WORKING_POINTS | 431 |
| 19.69 | XS_SINGLE_X_DIMENSION_TYPE | 431 |
| 19.70 | XS_SITE_BOLT_MARK_STRING_FOR_SIZE | 432 |
| 19.71 | XS_SITE_BOLT_MARK_STRING_FOR_SIZE_IN_GA | 433 |
| 19.72 | XS_SITE_HOLE_MARK_STRING_FOR_SIZE | 434 |
| 19.73 | XS_SITE_HOLE_MARK_STRING_FOR_SIZE_IN_GA | 435 |
| 19.74 | XS_SITE_LONGHOLE_MARK_STRING_FOR_SIZE | 436 |
| 19.75 | XS_SITE_LONGHOLE_MARK_STRING_FOR_SIZE_IN_GA | 437 |
| 19.76 | XS_SITE_OVERSIZEDHOLE_MARK_STRING_FOR_SIZE..... | 438 |
| 19.77 | XS_SITE_OVERSIZEDHOLE_MARK_STRING_FOR_SIZE_IN_GA..... | 439 |
| 19.78 | XS_SITE_TAPPEDHOLE_MARK_STRING_FOR_SIZE..... | 440 |
| 19.79 | XS_SITE_TAPPEDHOLE_MARK_STRING_FOR_SIZE_IN_GA..... | 441 |
| 19.80 | XS_SKIP_START_UP_SIGNIN_ON_PREMISE_LICENSING..... | 442 |
| 19.81 | XS_SNAPSHOT_DIRECTORY | 443 |
| 19.82 | XS_SOLID_BUFFER_SIZE | 443 |
| 19.83 | XS_SOLID_USE_HIGHER_ACCURACY | 444 |
| 19.84 | XS_STACKED_FRACTION_TYPE | 445 |
| 19.85 | XS_STANDARD_GUSSET_WIDTH_TOLERANCE | 445 |
| 19.86 | XS_STANDARD_STIFFENER_WIDTH_TOLERANCE | 446 |
| 19.87 | XS_STD_LOCALE..... | 446 |
| 19.88 | XS_STD_PART_MODEL | 447 |
| 19.89 | XS_STEEL1_TS_PAGE_9_EXTENSION..... | 447 |
| 19.90 | XS_STEEL1_TS_PAGE_10_EXTENSION..... | 448 |
| 19.91 | XS_STORE_MULTIPLE_BAK_FILES..... | 448 |
| 19.92 | XS_SUPERSCRIPT_HEIGHT_FACTOR | 449 |
| 19.93 | XS_SUPERSCRIPT_USED_IN_DRAWING_TEXTS..... | 449 |
| 19.94 | XS_SUPPORT_TOOL_EXCLUDE_ALL_FILES..... | 450 |
| 19.95 | XS_SWITCH_MULTI_NUMBERS_FOR | 450 |
| 19.96 | XS_SWITCH_POS_NUMBERS_FOR | 450 |
| 19.97 | SYMEDHOME | 451 |
| 19.98 | XS_SYSTEM | 451 |
| 19.99 | XS_SYSTEM_INTERNAL..... | 452 |
| 20 | Advanced options - T..... | 453 |
| 20.1 | TEMPLATE_FONT_CONVERSION_FILE | 453 |
| 20.2 | XS_TEMPLATE_DIRECTORY | 453 |
| 20.3 | XS_TEMPLATE_DIRECTORY_SYSTEM | 454 |

| | | |
|-----------|--|------------|
| 20.4 | XS_TEMPLATE_MARK_SUB_DIRECTORY..... | 454 |
| 20.5 | XS_TEXT_ORIENTATION_EPSILON..... | 455 |
| 20.6 | XS_THICKNESS_PARAMETER_IS_CROSS_SECTION_THICKNESS..... | 456 |
| 20.7 | XS_TPLED_INI | 457 |
| 20.8 | XS_TRY_TO_KEEP_LOCATION_IN_FREEPLACING | 457 |
| 20.9 | XS_TUBE_UNWRAP_LIMIT_THICKNESS | 457 |
| 20.10 | XS_TUBE_UNWRAP_PAPER_THICKNESS | 458 |
| 20.11 | XS_TUBE_UNWRAP_USE_PLATE_PROFILE_TYPE_IN_NC | 458 |
| 20.12 | XS_TUBE_UNWRAP_WITH_CUT_HOLES | 459 |
| 21 | Advanced options - U..... | 461 |
| 21.1 | XS_UEL_IMPORT_FOLDER..... | 461 |
| 21.2 | XS_UNDERLINE_AFTER_POSITION_NUMBER_IN_HARDSTAMP..... | 462 |
| 21.3 | XS_UNFOLDING_ANGLE_DIM_FORMAT | 462 |
| 21.4 | XS_UNFOLDING_DONT_USE_NEUTRAL_AXIS_FOR_RADIUS..... | 462 |
| 21.5 | XS_UNFOLDING_ANGLE_DIM_PRECISION | 463 |
| 21.6 | XS_UNFOLDING_PLANE_EPSILON | 464 |
| 21.7 | XS_UNIQUE_NUMBERS | 464 |
| 21.8 | XS_UNIQUE_ASSEMBLY_NUMBERS..... | 464 |
| 21.9 | XS_UPDATE_MARK_PLACING_IN_DRAWING | 465 |
| 21.10 | XS_UPDATE_MARKS_IN_FROZEN_DRAWINGS | 465 |
| 21.11 | XS_UPLOAD_SHARED_MODEL_TO_CONNECT..... | 466 |
| 21.12 | XS_UPSIDE_DOWN_TEXT_ALLOWED | 466 |
| 21.13 | XS_USABSOLUTE_TO_RELATIVE_LIMIT | 467 |
| 21.14 | XS_USABSOLUTE2_TO_RELATIVE_LENGTH_FACTOR | 468 |
| 21.15 | XS_USE_ANTI_ALIASING_IN_DX | 468 |
| 21.16 | XS_USE_ASSEMBLY_EXTREMA_IN_MARK_PLACING..... | 468 |
| 21.17 | XS_USE_ASSEMBLY_NUMBER_FOR | 470 |
| 21.18 | XS_USE_BOLT_DISTANCE_IN_NOTCH_CALCULATIONS | 471 |
| 21.19 | XS_USE_COLOR_DRAWINGS | 471 |
| 21.20 | XS_USE_CONVEX_PROTECT_AREA..... | 472 |
| 21.21 | XS_USE_CROSS_FOR_OPENING_SYMBOL..... | 472 |
| 21.22 | XS_USE_DRAWING_NAME_AS_PLOT_FILE_NAME | 473 |
| 21.23 | XS_USE_DYNAMIC_ROW_WIDTH_IN_TEMPLATES..... | 473 |
| 21.24 | XS_USE_DRAWING_NAME_AS_PLOT_TITLE | 475 |
| 21.25 | XS_USE_EIGHT_COLORS_IN_MODELING_VIEWS | 475 |
| 21.26 | XS_USE_EXACT_SOLID_FOR_CLASH_CHECK..... | 475 |
| 21.27 | XS_USE_EXISTING_SINGLE_PART_DRAWINGS_IN_ASSEMBLY_DRAWINGS. | 476 |
| 21.28 | XS_USE_EXISTING_SINGLE_PART_DRAWINGS_SCALE..... | 476 |
| 21.29 | XS_USE_FLAT_DESIGNATION | 477 |
| 21.30 | XS_USE_INTEGRATED_BUILDING_HIERARCHIES..... | 477 |

| | | |
|-------|--|-----|
| 21.31 | XS_USE_LINECLIP | 477 |
| 21.32 | XS_USE_LONG_POINTS_IN_DIMENSIONING..... | 478 |
| 21.33 | XS_USE_MODEL_PREFIX_IN_MULTI_NUMBERS_FOR | 479 |
| 21.34 | XS_USE_MULTI_NUMBERING_FOR..... | 480 |
| 21.35 | XS_USE_MULTI_NUMBERING_WHEN_COPYING_DRAWING_VIEWS | 481 |
| 21.36 | XS_USE_NEW_PLATE_DESIGNATION | 481 |
| 21.37 | XS_USE_NEW_WELD_PLACING | 482 |
| 21.38 | XS_USE_NEW_USNOTCH | 482 |
| 21.39 | XS_USE_NUMBER_SELECTED_FOR_DRAWING_CREATION_AND_UPDATE... | 483 |
| 21.40 | XS_USE_NUMERIC_MULTI_NUMBERS_FOR | 483 |
| 21.41 | XS_USE_OLD_DRAWING_CREATION_SETTINGS..... | 484 |
| 21.42 | XS_USE_OLD_DRAWING_EXPORT..... | 484 |
| 21.43 | XS_USE_OLD_DRAWING_LIST_DIALOG..... | 484 |
| 21.44 | XS_USE_OLD_PLOT_DIALOG..... | 485 |
| 21.45 | XS_USE_OLD_POLYBEAM_LENGTH_CALCULATION | 485 |
| 21.46 | XS_USE_ONLY_INCHES_IN_SHEET_SIZES | 486 |
| 21.47 | XS_USE_ONLY_INCHES_IN_WELD_LENGTH | 486 |
| 21.48 | XS_USE_ONLY_NOMINAL_REBAR_DIAMETER | 486 |
| 21.49 | XS_USE_OPENING_SYMBOL_IN_BORDER_HOLES..... | 487 |
| 21.50 | XS_USE_OPENING_SYMBOL_IN_CORNER_HOLES..... | 488 |
| 21.51 | XS_USE_PLATE_SIDE_POSITIONING | 489 |
| 21.52 | XS_USE_POINT_AS_SEPARATOR_IN_PROFILE_NAME | 490 |
| 21.53 | XS_USE_RECESS_SYMBOL_FOR_BORDER_AND_CORNER_RECESSES..... | 490 |
| 21.54 | XS_USE_REPAIR_NUMBERING_INSTEAD_OF_NUMBERING..... | 491 |
| 21.55 | XS_USE_ROUND_MAIN_PART_COORDINATES_FOR_SECONDARY_ PART_ANGLE..... | 491 |
| 21.56 | XS_USE_SCREW_POINT_ELEVATION_DIM..... | 492 |
| 21.57 | XS_USE_SMALLER_GUSSET_PLATE | 493 |
| 21.58 | XS_USE_SMART_PAN | 493 |
| 21.59 | XS_USE_SMOOTH_LINES | 494 |
| 21.60 | XS_USE_SOFTWARE_RENDERING | 494 |
| 21.61 | XS_USE_SPECIAL_FILLER_PLATE_THICKNESS | 494 |
| 21.62 | XS_USE_TUBE_INNER_LENGTH_IN_DIMENSIONING | 495 |
| 21.63 | XS_USE_UP_DOWN_SIGN_INDICATOR_FOR_ANGLE_IN_UNFOLDING..... | 495 |
| 21.64 | XS_USE_USABSOLUTE_ARROW_TYPE_FOR_ABSOLUTE_DIMENSIONS..... | 496 |
| 21.65 | XS_USE_USER_DEFINED_REBAR_LENGTH_AND_WEIGHT..... | 496 |
| 21.66 | XS_USE_USER_DEFINED_REBARSHAPERULES..... | 497 |
| 21.67 | XS_USE_VERTICAL_PLACING_FOR_COLUMNS_IN | 497 |
| 21.68 | XSUSERDATADIR..... | 498 |
| 21.69 | XS_USER_DEFINED_BOLT_SYMBOL_TABLE | 498 |
| 21.70 | XS_USER_DEFINED_PARAMETRIC_PROFILE_SEPARATORS | 498 |

| | | |
|-----------|---|------------|
| 21.71 | XS_USER_SETTINGS_DIRECTORY..... | 499 |
| 22 | Advanced options - V..... | 500 |
| 22.1 | XS_VALID_CHARS_FOR_ASSEMBLY_FAMILY_POSITION_NUMBERS | 500 |
| 22.2 | XS_VALID_CHARS_FOR_ASSEMBLY_FAMILY_QUALIFIER | 500 |
| 22.3 | XS_VALID_CHARS_FOR_ASSEMBLY_MULTI_NUMBERS | 501 |
| 22.4 | XS_VALID_CHARS_FOR_ASSEMBLY_POSITION_NUMBERS | 501 |
| 22.5 | XS_VALID_CHARS_FOR_PART_MULTI_NUMBERS | 502 |
| 22.6 | XS_VALID_CHARS_FOR_PART_POSITION_NUMBERS | 502 |
| 22.7 | XS_VALID_CHARS_FOR_REBAR_SUB_ID_WITH_LETTERS..... | 503 |
| 22.8 | XS_VIEW_DIM_LINE_COLOR | 503 |
| 22.9 | XS_VIEW_DIM_TEXT_COLOR | 504 |
| 22.10 | XS_VIEW_FAST_BOLT_COLOR..... | 504 |
| 22.11 | XS_VIEW_FRAMES_VISIBLE..... | 505 |
| 22.12 | XS_VIEW_FREE_MEASURE_PLANE..... | 505 |
| 22.13 | XS_VIEW_HEIGHT | 506 |
| 22.14 | XS_VIEW_PART_LABEL_COLOR | 506 |
| 22.15 | XS_VIEW_POSITION_X | 507 |
| 22.16 | XS_VIEW_POSITION_Y | 507 |
| 22.17 | XS_VIEW_TITLE_FONT | 508 |
| 22.18 | XS_VIEW_WIDTH | 508 |
| 22.19 | XS_VISUALIZE_VIEW_IN_ANOTHER_VIEWS..... | 508 |
| 22.20 | XS_VISUALIZE_VIEW_IN_FATHER_VIEW_ONLY..... | 509 |
| 22.21 | XS_VISUALIZE_VIEW_NEIGHBOUR_PART_EXTENSION..... | 509 |
| 23 | Advanced options - W..... | 510 |
| 23.1 | XS_WARP_MAX_ANGLE_BETWEEN_CS | 510 |
| 23.2 | XS_WARP_MAX_DEVIATION | 510 |
| 23.3 | XS_WELD_FILTER_TYPE | 511 |
| 23.4 | XS_WELD_FONT | 511 |
| 23.5 | XS_WELDING_LENGTH_TOLERANCE | 511 |
| 23.6 | XS_WELDING_TOUCH_TOLERANCE | 512 |
| 23.7 | XS_WELD_LENGTH_CC_SEPARATOR_CHAR | 512 |
| 23.8 | XS_WELD_NUMBER_FORMAT | 512 |
| 23.9 | XS_WORKING_POINTS_VALID_ALSO_OUTSIDE_PART | 513 |
| 23.10 | XS_ZERO_POINT_SYMBOL_OLD_WAY | 513 |
| 24 | Advanced options - Z..... | 514 |
| 24.1 | XS_ZOOM_STEP_RATIO | 514 |
| 24.2 | XS_ZOOM_STEP_RATIO_IN_MOUSEWHEEL_MODE..... | 514 |
| 24.3 | XS_ZOOM_STEP_RATIO_IN_SCROLL_MODE | 515 |

| | | |
|-----------|------------------------|------------|
| 25 | Disclaimer..... | 516 |
|-----------|------------------------|------------|

1 Advanced options

Advanced options customize your version of Tekla Structures. For example, they set various file names and locations, define symbols used in drawings, change how numbering is done, and so on.

Check and change advanced option values

Most advanced options are available in the user interface. To access the options, click **File menu** --> **Settings** and in the **Settings** area select **Advanced options**.

Some advanced options are not shown in the **Advanced options** dialog box and can only be set in initialization files; the documentation of the option mentions when this is the case.

The default values given for the advanced options in the documentation are for the Default environment. The values may be different in localized environments. If you want to change the defaults used in your projects, add the advanced options in an initialization file that is located in a project or firm folder. Settings in the initialization files do not change existing selections in models. They are used when you create a new model and when you add values for options that have no previous value in the model.

To list all advanced option values set in the current model, including those set in initialization files, click the **Write to file** button at the bottom of the **Advanced options** dialog box.

Find the documentation for advanced options

To see the documentation for those advanced options that are shown in the **Advanced options** dialog box, select an advanced option in the dialog box and press F1 on your keyboard. This opens the correct help page for the option, and often provides additional information even for those options that have a short description directly in the dialog box.

Here in the documentation, we list the advanced options alphabetically (see the attached listing), ignoring the initial letters XS. For example, under **A** you will find the advanced option `XS_AISC_WELD_MARK`, under **B**, `XS_BACKGROUND_COLOR`, and so on. Advanced options starting with `XSR` are listed under **R**.

Search for advanced options

The regular search is configured to find advanced options.

When you type "XS_WELD", you will see suggestions to choose from. When you perform the search, you will see all advanced options containing "XS_WELD" first and then after that those containing "WELD".

If you search for advanced options but only know a part of the name, first select the **Functionality filter: Advanced options** and then type your search word, for example "WELD". You will get [a list of all advanced options containing that word](#).

2 Advanced options - A

2.1 XS_AD_ANALYSIS_PLANES_ENABLED

Category: Analysis and design

Set this advanced option to `FALSE` to revert to the analysis model creation method used in Tekla Structures 2017i and earlier versions.

The default value is `TRUE`.

If you change the value, Tekla Structures recreates the analysis models.

This advanced option is model specific and the setting is saved in the options database.

2.2 XS_AD_CURVED_BEAM_SPLIT_ACCURACY_MM

Category: Analysis & Design

When **Curved beams** is set to **Split into straight segments** in the analysis model properties, curved beams are approximated using polylines in the analysis model. This advanced option defines how closely the straight polyline segments follow the curved beams.

Use this advanced option to set the maximum distance between a curved beam and a straight segment. Enter the value in millimeters. The default value is 25.0 mm.

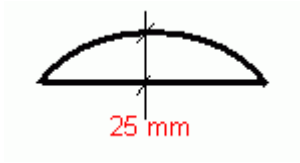

This advanced option is model specific and the setting is saved in the options database.

2.3 XS_AD_DRAW_BAR_DIAMETER_MM

Category: Analysis and design

Use this advanced option to define the diameter of the analysis parts when the analysis parts are shown in model views. Enter the value in millimeters. The default value is 70 mm.

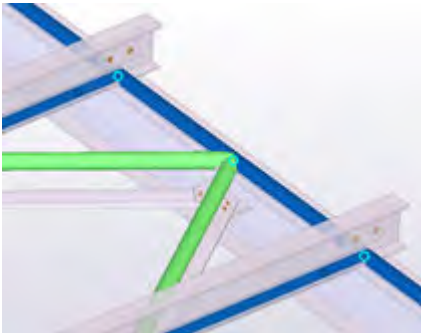

This advanced option is user specific and the setting is saved in `options.bin` under the user folder, for example, in `C:\Users\\AppData\Local\Trimble\Tekla Structures\\UserSettings`. Redraw the model views after changing the value to activate the new setting.

See also

[XS_AD_DRAW_NODE_SCALE](#) (page 30)

2.4 XS_AD_DRAW_NODE_SCALE

Category: Analysis and design

Use this advanced option to scale the size of the analysis nodes when the analysis nodes are shown in model views. The default value is 1.

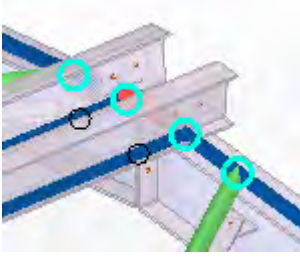

This advanced option is user specific and the setting is saved in `options.bin` under the user folder, for example, in `C:\Users\\AppData\Local\Trimble\Tekla Structures\\UserSettings`. Redraw the model views after changing the value to activate the new setting.

See also

[XS_AD_DRAW_BAR_DIAMETER_MM](#) (page 30)

2.5 XS_AD_ELEMENT_ANGLE_CHECK_ANGLE_DIFF_LIMIT

Category

Analysis & Design

Use to set a limit angle between physical part and analysis model member, in order to test the validity of the analysis model. When the angle is greater than the limit, a message appears and a warning is added to the log. Small differences in angles are usual in the analysis model of a truss, for example. The default value is `10.0`.

This advanced option is model specific and the setting is saved in the options database.

2.6 XS_AD_ENVIRONMENT

Category

Analysis & Design

This advanced option is used in analysis and design integration to set the environment, for example, to set the cross section catalog. The default value is `Europe`.

Possible values are dependent on the analysis application that is used. For some applications, this advanced option is not used.

This advanced option is model specific and the setting is saved in the options database.

2.7 XS_AD_GET_MOMENT_CONNECTION_STATUS

Category

Analysis & Design

Use to specify to which value (**Yes** or **No**) the **Moment connection symbols** option is set when the **Get results** command is used in the analysis model. The **Moment connection symbols** option is available on the **End conditions** tab in the user-defined attributes properties dialog box of the part, and it defines whether the moment connection symbols are shown in drawings.

Set the advanced option to one of the following values:

- `yz`: if the rotations `ry` and `rz` are fixed in the analysis model, the value **Yes** is used, otherwise **No** is used.
- `xyz`: if all rotations are fixed in the analysis model, the value **Yes** is used, otherwise **No** is used.
- `z`: if the rotation `rz` is fixed in the analysis model, the value **Yes** is used, otherwise **No** is used.
- The advanced option is not set: The value you have set manually in the **Moment connection symbols** option is used.

The default is `yz`.

This advanced option is model specific and the setting is saved in the options database.

2.8 XS_AD_GET_RESULTS_DESIGN_VALUES

Category

This advanced option must be set in an initialization (.ini) file.

Set this advanced option to `TRUE` to import steel and concrete design values from Robot into Tekla Structures when you use the **Get results** or **Get results for selected** command in the **Analysis & Design Models** dialog box. The default value is `TRUE`. If you do not want to import the design values, set this advanced option to `FALSE`.

See also

[XS_AD_GET_RESULTS_FORCES \(page 32\)](#)

2.9 XS_AD_GET_RESULTS_FORCES

Category

This advanced option must be set in an initialization (.ini) file.

Set this advanced option to `TRUE` to import forces from Robot into Tekla Structures when you use the **Get results** or **Get results for selected** command in the **Analysis & Design Models** dialog box. The default value is `FALSE`.

See also

[XS_AD_GET_RESULTS_DESIGN_VALUES](#) (page 32)

2.10 XS_AD_LOAD_COMBINATION_METHOD

Category: Analysis and design

Use this advanced option to define whether a load combination is created instead of a repeated load in STAAD.Pro export from Tekla Structures.

Set to 0 to use `REPEAT LOAD`, or set to 1 to use `LOAD COMBINATION`.

The default value is 0.

This advanced option is model specific and the setting is saved in the options database.

2.11 XS_AD_MEMBER_NUMBER_VISUALIZATION

Category

Analysis & Design

Use to show or hide member numbers when displaying the analysis model in a model view. The default is `TRUE`, which shows the numbers. To hide the numbers, set to `FALSE`.

This advanced option is model specific and the setting is saved in the options database.

2.12 XS_AD_MEMBER_RESULT_DISP_DIVISION_COUNT

Category

Analysis & Design

Use to define the analysis member points whose results are saved in the `analysis_results.db5` database. This advanced option defines into how many parts each analysis member is divided.

Enter an integer value. The default is 0, which does not save any displacement results.

This advanced option is model specific and the setting is saved in the options database.

Example

To save only the displacements of member ends, set `XS_AD_MEMBER_RESULT_DISP_DIVISION_COUNT` to 1.

To save three intermediate displacement results, in addition to the end displacements, set `XS_AD_MEMBER_RESULT_DISP_DIVISION_COUNT` to 4.

See also

[XS_AD_MEMBER_RESULT_MIN_DISTANCE](#) (page 35)

[XS_AD_MEMBER_RESULT_DIVISION_COUNT](#) (page 34)

2.13 XS_AD_MEMBER_RESULT_DIVISION_COUNT

Category

Analysis & Design

Use to define the analysis member points whose results are saved in the `analysis_results.db5` database. This advanced option defines into how many parts each analysis member is divided.

The default is 1, which saves only the results of member ends.

This advanced option is model specific and the setting is saved in the options database.

Example

To save the results of three intermediate points (quartiles) on each member, in addition to the end results, set `XS_AD_MEMBER_RESULT_DIVISION_COUNT` to 4.

See also

[XS_AD_MEMBER_RESULT_MIN_DISTANCE \(page 35\)](#)

[XS_AD_MEMBER_RESULT_DISP_DIVISION_COUNT \(page 33\)](#)

2.14 XS_AD_MEMBER_RESULT_GRID_SIZE

Category

Analysis & Design

Use to define the grid spacing for the analysis results of plates, slabs, and panels. Enter the value in millimeters. The default value is 500.

This advanced option is model specific and the setting is saved in the options database.

2.15 XS_AD_MEMBER_RESULT_MIN_DISTANCE

Category

Analysis & Design

Use to define the minimum distance between the analysis result points on analysis members. Enter the value in millimeters. The default value is 500.

This advanced option is model specific and the setting is saved in the options database.

See also

[XS_AD_MEMBER_RESULT_DIVISION_COUNT \(page 34\)](#)

[XS_AD_MEMBER_RESULT_DISP_DIVISION_COUNT \(page 33\)](#)

2.16 XS_AD_MEMBER_TYPE_VISUALIZATION

Category: Analysis and design

Use colors to show different analysis part types when displaying the analysis model in a model view. The default setting is `TRUE`, which shows the analysis parts using the analysis class colors. A setting of `FALSE` shows the plate objects using the analysis class colors and the other analysis parts in blue.

This advanced option is model specific and the setting is saved in the options database.

2.17 XS_AD_NEAR_NODES_WARNING_LIMIT

Category

Analysis & Design

Use this advanced option to trigger a warning when analysis nodes are closer to each other than the limit.

Enter the limit in millimeters. The default value is 0, which means that Tekla Structures does not show warnings.

This advanced option is model specific and the setting is saved in the options database.

Example

To have Tekla Structures show a warning for analysis nodes that are closer than 5 mm to each other, set `XS_AD_NEAR_NODES_WARNING_LIMIT` to 5.

See also

[XS_AD_SHORT_MEMBER_WARNING_LIMIT \(page 39\)](#)

[XS_AD_SHORT_RIGIDLINK_WARNING_LIMIT \(page 39\)](#)

2.18 XS_AD_NODE_NUMBER_BY_Z

Category: Analysis and design

If you set this advanced option to `TRUE`, the start number of a new analysis node is set according to the global z coordinate of the node. For example:

- If z is less than 1000.0, the node start number is 0.
- If z is between 1000.0 and 1999.0, the node start number is 1000.
- If z is between 2000.0 and 2999.0, the node start number is 2000.

The first free number above the start number is assigned to the node.

The default is `FALSE`.

2.19 XS_AD_NODE_NUMBER_VISUALIZATION

Category

Analysis & Design

Use to show or hide node numbers when displaying the analysis model in a model view. The default is `TRUE`, which shows the numbers.

This advanced option is model specific and the setting is saved in the options database.

2.20 XS_AD_OPTIMISATION_DISABLED

Category

Analysis & Design

Use to check profile catalog analysis values. To enable design optimization, use the value `FALSE`. To disable design optimization, use the value `TRUE`. The default value is `FALSE`.

This advanced option is model specific and the setting is saved in the options database.

See also

[XS_PROFILE_ANALYSIS_CHECK_ALL \(page 348\)](#)

2.21 XS_AD_OPTIMISATION_NO_WEIGHT_SORT

Category

Analysis & Design

When optimization cross section group is extracted from the profile catalog, the group is sorted by default according to the section weight (cross section area). Set this advanced option to `TRUE` to disable this sorting, in which case the section order is the same as in the profile catalog.

If you use the value `FALSE`, the group is sorted according to the section weight. The default value is `FALSE`.

This advanced option is model specific and the setting is saved in the options database.

2.22 XS_AD_OPTIMISATION_RECURSE_CATALOG

Category

Analysis & Design

Set this advanced option to `TRUE` to have Tekla Structures ignore profile catalog rules for optimizing steel part sizes and search the entire profile catalog. If you want to take the rules into account, set it to `FALSE`. The default value is `TRUE`.

This advanced option is model specific and the setting is saved in the options database.

2.23 XS_AD_RESULT_DATABASE_ENABLED

Category

Analysis & Design

Use to define whether the analysis results database `analysis_results.db5` is created or not. The default setting is `TRUE`. This creates the analysis results database.

If you decide not to create the analysis results database, set this advanced option to `FALSE`. In this way the use of large models with several load combinations is faster and less memory consuming.

This advanced option is model specific and the setting is saved in the options database.

2.24 XS_AD_RIGID_DIAPHRAGM_VISUALIZATION

Category

Analysis & Design

Defines whether extra sticks are drawn in visualization for rigid diaphragms.

This advanced option is model specific and the setting is saved in the options database.

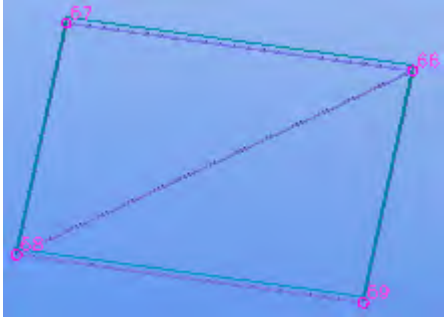
| Advanced option is set to | Appearance |
|---------------------------|--|
| TRUE (default) |  |

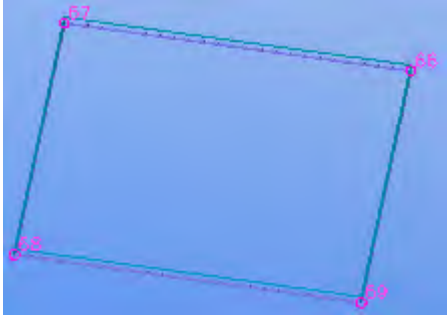
| Advanced option is set to | Appearance |
|---------------------------|--|
| FALSE |  |

2.25 XS_AD_SHORT_MEMBER_WARNING_LIMIT

Category

Analysis & Design

Use this advanced option to trigger a warning when a analysis member is shorter that the limit.

Enter the length in millimeters. Default is 50. If the limit is set to 0, no checking is done.

This advanced option is model specific and the setting is saved in the options database.

2.26 XS_AD_SHORT_RIGIDLINK_WARNING_LIMIT

Category

Analysis & Design

Use this advanced option to trigger a warning when an analysis rigid link is shorter that the limit. Enter the length in millimeters. Default is 10. If the limit is set to 0, no checking is done.

This advanced option is model specific and the setting is saved in the options database.

2.27 XS_AD_SOLID_AXIAL_EXPAND_MM

Category: Analysis and design

Used in analysis model creation when checking if parts are clashing. Parts are expanded in axial direction by the given distance to create clash also when there is a small gap between parts. The default value is 25.

This advanced option is model specific and the setting is saved in the options database.

See also

[XS_AD_SOLID_SECONDARY_EXPAND_MM \(page 40\)](#)

2.28 XS_AD_SOLID_SECONDARY_EXPAND_MM

Category: Analysis and design

Used in analysis model creation when checking if parts are clashing and if they should be connected in the analysis model. Secondary parts are expanded in all directions by the given distance to create clash also when there is a gap between parts. The default value is 75.

This advanced option is model specific and the setting is saved in the options database.

See also

[XS_AD_SOLID_AXIAL_EXPAND_MM \(page 39\)](#)

2.29 XS_AD_SUPPORT_VISUALIZATION

Category

Analysis & Design

Use to show or hide the support conditions when showing the analysis model in a model view. The default is `TRUE`, which shows the support conditions.

This advanced option is model specific and the setting is saved in the options database.

2.30 XS_AD_USE_HIGH_ACCURACY

Category

Analysis & Design

Set this advanced option to `FALSE` to allow for more tolerance in the creation of the analysis model. In certain situations this will result in a more suitable analysis model. If you do not want to allow more tolerance in the analysis mode creation, set this advanced option to `TRUE`. The default value is `FALSE`.

This advanced option is model specific and the setting is saved in the options database.

2.31 XS_ADAPTIVE_OBJECTS

Category: Modeling properties

Use to define which adaptivity method to use. The options are:

- `ENABLED`: the new adaptivity method is used
- `ENABLED_OLD`: the old adaptivity method is used
- `DISABLED`: adaptivity is disabled

The default value is `ENABLED`.

This advanced option is model specific and the setting is saved in the options database.

2.32 XS_ADD_SNAPPING_SYMBOL_TO_CIRCLES

Category: Drawing properties

Set this advanced option to `TRUE` to have the snapping point in the center of circles while you are snapping to the center of circles created in the model by using polygon cuts. You may need to snap to center of circles when you need to create dimensions, for example. The default value is `FALSE`.

If you change the value, you need to reopen the drawing.

This advanced option is model specific and the setting is saved in the options database.

2.33 XS_ADJUST_GRID_LABELS

Category

Model View

Set this advanced option to `FALSE` to disable the dynamic moving of grid labels when zooming in, and to keep the labels anchored to the end of the grid line. The default value is `TRUE`, and the grid line labels are kept visible. When working with very large grids having the grid labels always visible might slow down Tekla Structures. After you change the advanced option setting, close and re-open the view to implement the change.

2.34 XS_AISC_WELD_MARK

Category: Welds

Set this advanced option to `TRUE` to create AISC weld marks, to use leg length as default fillet weld size dimensioning, and to create arrow side weld using below line weld properties.

Set this advanced option to `FALSE` to create ISO weld marks, to use throat thickness as default fillet weld size dimensioning, and to create arrow side weld using above line weld properties. `FALSE` is the default value.

This advanced option also affects the spacing of intermittent welds:

- `TRUE` uses the **Pitch** value entered in the weld properties as the center-to-center spacing of welds.
- `FALSE` uses the **Pitch** value entered in the weld properties as the spacing between the welds.

An AISC weld mark of a staggered intermittent weld with the pitch after a dash:

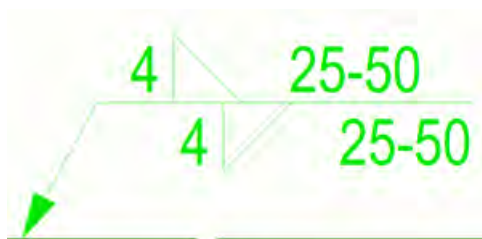

An ISO weld mark of a staggered intermittent weld with the distance between weld elements in parenthesis



This advanced option is model specific and the setting is saved in the options database.

NOTE The `XS_AISC_WELD_MARK` advanced option is delivered with model folder files. If you need to deliver the model to another party, send the full model with all files (not just the model database file `*.db1`) to ensure that the weld cross section size remains the same. If the value for this advanced option is changed, then the actual weld cross-section size will change accordingly.

2.35 XS_ALLOW_DRAWING_TO_MANY_MULTI_DRAWINGS

Category

Numbering

Set this advanced option to `TRUE` to allow the same drawings to be included in more than one multidrawing.

If you want the drawing to be included in only one multidrawing, set this value to `FALSE` (default).

This advanced option is model specific and the setting is saved in the options database.

2.36 XS_ALLOW_INCH_MARK_IN_DIMENSIONS

Category: Dimensioning - general

Set to `TRUE` to have Tekla Structures include the inch symbol in dimensions. The default value is `TRUE`. If you do not want to allow inch marks, set this advanced option to `FALSE`.

TRUE:

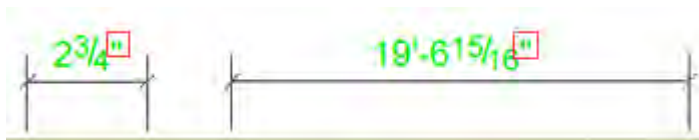

FALSE:

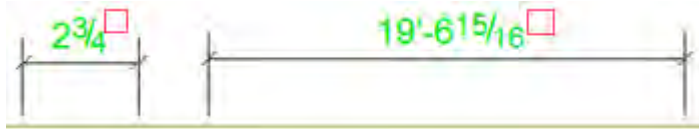

This advanced option is role specific. When the type **SYSTEM(ROLE)** is in use, the default value is used. When the type **MODEL(ROLE)** or **DRAWING(ROLE)** is in use, you can change the value, which is then the same for all users in the current model.

2.37 XS_ALLOW_INCH_MARK_IN_WELD_SYMBOLS

Category: Imperial Units

Set this advanced option to `TRUE` to have Tekla Structures include the inch symbol (") in weld symbols. If you do not want to include the inch symbol, set it to `FALSE` (default).

`TRUE`:



This advanced option is model specific and the setting is saved in the options database.

2.38 XS_ALLOW_REBARS_ON_TOP_OF_EACH_OTHER

Category

Concrete Detailing

If you set this advanced option to `TRUE`, reinforcing bars can be drawn on top of each other. In this case you have selected **Visibility of reinforcing bars in group** to **bar in the middle of group** or to **customized**, and you have two reinforcing bar groups on top of each other, for example, on the top surface of a slab and on the bottom surface of a slab. The default value is `FALSE`. This advanced option is model specific and the setting is saved in the options database.

2.39 XS_ALLOW_REINFORCING_LOCKED_PARTS

This advanced option must be set in an initialization (.ini) file.

Set to `TRUE` to create, modify, or delete reinforcement in parts that have been locked. This is useful, for example, when different parties of a project are responsible for modeling concrete parts and for modeling reinforcement, and when modification of parts needs to be prevented.

2.40 XS_ALLOW_SHEAR_PLATE_CLASH_FLANGE

Category

Components

Set this advanced option to `TRUE` (default) to omit the default 0.3 mm tolerance between shear tab and secondary part web for shear tab components. To use the tolerance, set it to `FALSE`.

This advanced option is model specific and the setting is saved in the options database.

2.41 XS_ALWAYS_CONFIRM_SAVE_WHEN_CLOSING_DRAWING

Category

Drawing Properties

Set this advanced option to `TRUE` to always display the confirmation message "Do you want to save current drawing?".

The default value is `FALSE`. This means that if you close a drawing without making any changes, Tekla Structures does not by default prompt you to save the drawing.

This advanced option is user specific and the setting is saved in `options.bin` under the user folder, for example, in `C:\Users\\AppData\Local\Trimble\Tekla Structures\\UserSettings`. Restart Tekla Structures to activate the new value.

2.42 XS_ALWAYS_CONFIRM_SAVE_WHEN_EXIT

Category

Modeling Properties

Use to define whether or not Tekla Structures prompts you to save the model if you are closing it without making any changes.

If this advanced option is set to `TRUE` (default), Tekla Structures always asks you to save the model when closing it.

If this advanced option is set to `FALSE`, Tekla Structures does not ask you to save the model if there are no changes after the last save.

This advanced option is user specific and the setting is saved in `options.bin` under the user folder, for example, in `C:\Users\\AppData\Local\Trimble\Tekla Structures\\UserSettings`. Restart Tekla Structures to activate the new value.

2.43 XS_ANCHOR_BOLT_PLAN_ADDITIONAL_PARTS_FILTER

Category Drawing properties

Use to add additional parts that are not usually part of a column assembly to an anchor bolt plan, such as anchor rods or leveling plates. First define a general arrangement drawing filter and then give that filter name as the value for this advanced option.

This advanced option is model specific and the setting is saved in the options database.

In the following example we will make anchor rods and leveling plates visible in an anchor bolt plan.

1. Go to the **File** menu and click **Settings --> Advanced options --> Drawing Properties**.
2. Enter the name of the general arrangement drawing filter for the advanced option `XS_ANCHOR_BOLT_PLAN_ADDITIONAL_PARTS_FILTER`. In this example, we will use the name `SHOW_IN_ABPLAN` (default).
3. On the **Drawings & Reports** tab, click **Drawing properties > GA drawing**.
4. In the general arrangement drawing properties dialog box, click **Filter**.
5. Click **Add row**.
6. Select **Part** as the **Category**, **Name** as the **Property**, **Equals** as the **Condition** and enter `*ANCHOR*LEVEL` in the **Value** box.
7. Enter the name of the drawing filter, `SHOW_IN_ABPLAN`, in the **Save as** box and click **Save as**.

8. Click **Cancel** to exit the dialog box.

When you create an anchor bolt plan, both the anchor rods and the leveling plates are shown in the drawing. In the drawing below, the name of the anchor rod is "ANCHOR ROD" and the name of the leveling plate is "LEVELING PLATE."

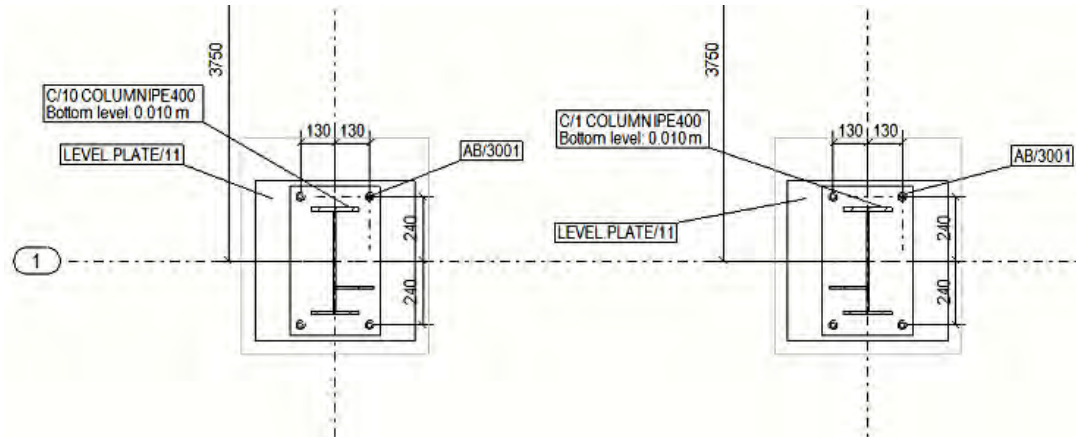

2.44 XS_ANCHOR_BOLT_PLAN_BASEPLATE_FILTER

Category

Drawing Properties

Use a general arrangement drawing filter to limit the number of visible objects to determine the parts to be included in the anchor bolt plan. First create the base plate filter, then enter its name as the value for the advanced option. Tekla Structures will show in the anchor bolt plan the base plates defined by the drawing filter.

If this advanced option is set, base plate is a part that fulfills the following rules:

- Part belongs to the same assembly as the column, which is the main part of the assembly.
- Part passes the drawing filter specified by
`XS_ANCHOR_BOLT_PLAN_BASEPLATE_FILTER`.

If there is more than one part in the column assembly that fulfills the rules, the lowest part is considered to be the base plate.

This advanced option is model specific and the setting is saved in the options database.

Example

`XS_ANCHOR_BOLT_PLAN_BASEPLATE_FILTER = <the name of the drawing filter for base plates>`

2.45 XS_ANCHOR_BOLT_PLAN_BOLT_FILTER

Category

Drawing Properties

Use a general arrangement drawing filter to limit the number of visible objects in a drawing and determine the parts to be included in the anchor bolt plan. First create the general arrangement drawing bolt filter, then enter its name as the value for this advanced option. Tekla Structures will show in the anchor bolt plan the bolts included in the drawing filter.

This advanced option is model specific and the setting is saved in the options database.

Example

```
XS_ANCHOR_BOLT_PLAN_BOLT_FILTER=<the name of the drawing  
filter for bolts>
```

2.46 XS_ANCHOR_BOLT_PLAN_COLUMN_FILTER

Category

Drawing Properties

Use a general arrangement drawing view filter to limit the number of visible objects and determine the parts to be included in the anchor bolt plan. First create a general arrangement drawing column filter, then enter its name as the value for this advanced option. Tekla Structures will show in the anchor bolt plan the columns included in the filter.

This advanced option is model specific and the setting is saved in the options database.

Example

```
XS_ANCHOR_BOLT_PLAN_COLUMN_FILTER=<the name of the drawing  
filter for columns>
```

2.47 XS_ANCHOR_BOLT_PLAN_DRAWING_TOLERANCE

Category: Drawing properties

Use to specify the distance of an assembly from the view plane for the assembly to be included in the anchor bolt plan. Enter the distance in millimeters. The default value is 200.

If you have anchor bolts at varying elevations, you can create a general arrangement drawing at the level of the top-most base plate/anchor bolt. The anchor bolt plan view extrema looks downwards. If the lowest level anchor bolt is not shown, adjust the advanced option

`XS_ANCHOR_BOLT_PLAN_DRAWING_TOLERANCE`.

This advanced option is model specific and the setting is saved in the options database.

2.48 XS_ANCHOR_BOLT_PLAN_USE_VIEW_COORDSYS_FOR_BOLT_DIMENSIONS

Category

Drawing Properties

Use to select the direction for the dimensions in the anchor bolt plans. If set to `TRUE`, anchor bolt plan detail view dimensions are created using the coordinate system of the main view. This advanced option is set to `FALSE` by default, which means that the dimensions of anchor bolt plan detail views are created according to the base plate coordinate system.

This advanced option is model specific and the setting is saved in the options database.

2.49 XS_ANGLE_DEGREE_SIGN

Category

Drawing Properties

Use to show the degree symbol correctly in Asian languages. By default, the value is `unicode:176`. The value can be changed depending on the desired character. To add the degree symbol in an Asian language, copy the symbol from a text file and paste it directly in the value field. Do not use a unicode value.

This advanced option is model specific and the setting is saved in the options database.

2.50 XS_ANGLE_DIMENSION_SYMBOL_SIZE_FACTOR

Category

Dimensioning: General

Use to define the size of angle symbols.

This advanced option is model specific and the setting is saved in the options database.

Value 1

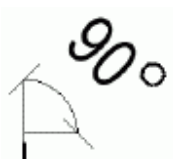

Value 3 (default)

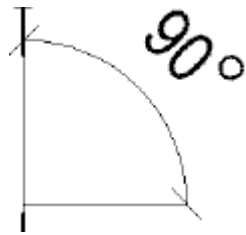

Value 5

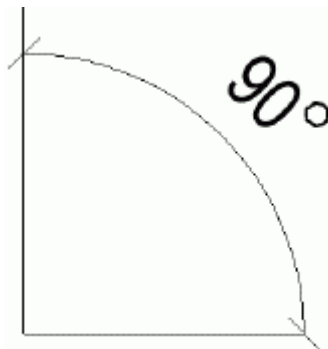

NOTE Setting this advanced option disables the advanced option `XS_CHECK_TRIANGLE_TEXT_SIZE`.

See also

[XS_CHECK_TRIANGLE_TEXT_SIZE](#) (page 91)

2.51 XS_ANGLE_TEXT_IN_UNFOLDING_BENDING_LINE_DIMENSIONING

Category: Dimensioning: Unfolding

Use to set the prefix text for unfolded angles. This affects single-part drawings that show folded parts unfolded. Enter any text, for example, A=. By default, there is no prefix text.

This advanced option is model specific and the setting is saved in the options database.

2.52 APPL_ERROR_LOG

This advanced option must be set in an initialization (.ini) file.

This advanced option is system specific and is read from `teklastructures.ini`. Generally, there is no need to modify system-specific settings. Do not modify them if you are not an administrator.

This advanced option tells the prefix of the application error log files.

Example

If you enter `set APPL_ERROR_LOG=TeklaStructures`, Tekla Structures creates at least the following log files by default in

`C:\TeklaStructuresModels\` folder:

- `TeklaStructures_%USERNAME%.log`: log data collected while the program is running
- `TeklaStructures_%USERNAME%.err`: errors collected while the program is running

2.53 XS_APPLICATIONS

This advanced option is deprecated, but still supported in Tekla Structures version 2022 and older Tekla Structures versions. Instead of this advanced option, we recommend that you use [XS_APPLICATIONS_PATH \(page 51\)](#), which allows you to define several application file locations.

This advanced option must be set in an initialization (.ini) file.

This advanced option is system specific and is read from `teklastructures.ini`. Generally, there is no need to modify system-specific settings. Do not modify them if you are not an administrator.

This advanced option defines the folder that contains the connection, detail, and detailing tool applications.

Example

```
set XS_APPLICATIONS=%XS_DIR%\applications\
```

2.54 XS_APPLICATIONS_PATH

This advanced option must be set in an initialization (.ini) file.

This advanced option is system specific and is read from `teklastructures.ini`. Generally, there is no need to modify system-specific settings. Do not modify them if you are not an administrator.

This advanced option defines the folders that contain the connection, detail, and detailing components.

Example

```
set XS_APPLICATIONS_PATH=%XS_APPLICATIONS%;%XSDATADIR
%environments\common\Extensions\applications\
```

The order in which the elements are placed affects how the applications and application settings are used. Tekla Structures reads the first elements first.

2.55 XS_ARC_WIDTH_OF_CLOUD

Category

Drawing Properties

Use to control the width of cloud arcs on paper (default 10 mm). You can use the **Cloud** tool to highlight changes in drawings.

This advanced option is model specific and the setting is saved in the options database.

Example

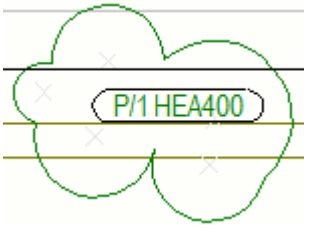
| Advanced option is set to | Example of appearance in drawing |
|---------------------------|--|
| 1 |  |
| 10 |  |

2.56 XS_ASCII_IMPORT_CREATES_CONSTRUCTION_LINES

Category

Import

Set this advanced option to `TRUE` to have Tekla Structures only draw construction lines between object points in an ASCII import. If you do not want to do this, set it to `FALSE` (default).

This advanced option is model specific and the setting is saved in the options database.

2.57 XS_ASSEMBLY_DRAWING_VIEW_TITLE

Category: Drawing properties

Use to define a title for assembly drawing views in a **multidrawing**.

Enter any combination of text and options, and enclose each option in percent symbols (%).

Example: No. %MODEL_NUMBER%, Marked %ASSEMBLY_POS%

The options are:

- PART_NAME
- PART_MATERIAL
- PART_POS
- ASSEMBLY_POS
- MODEL_NUMBER
- LENGTH
- PROFILE
- MAIN_PART_LENGTH
- DRAWING_BASE_NAME
- DRAWING_NAME

This advanced option is role specific. When the type **SYSTEM(ROLE)** is in use, the default value is used. When the type **MODEL(ROLE)** or **DRAWING(ROLE)** is in use, you can change the value, which is then the same for all users in the current model.

2.58 XS_ASSEMBLY_FAMILY_POSITION_NUMBER_FORMAT_STRING

Category: Numbering

Use to define the contents of the assembly family position number. For example, instead of DT1-1, DT1-2, you can define the numbering as DT1-A, DT1-B.

To get this result, set the advanced option as follows:

```
XS_ASSEMBLY_FAMILY_POSITION_NUMBER_FORMAT_STRING=
%ASSEMBLY_PREFIX%%ASSEMBLY_FAMILY_NUMBER%-
%ASSEMBLY_FAMILY_QUALIFIER_WITH_LETTERS%
```

This advanced option is model specific and the setting is saved in the options database.

Use the following options to define the contents of family position numbers. Use as many options as you need, and enclose each one in percent symbols (%).

| Option | Description |
|--|---|
| %ASSEMBLY_PREFIX% | Assembly prefix, defined in the part properties in the property pane. |
| %ASSEMBLY_POS% | The running assembly position number, starting from the start number, defined in the part properties in the property pane. |
| %ASSEMBLY_FAMILY_NUMBER% | Assembly family number, defined by the start number (in part properties in the property pane) and the final position in that numbering series. |
| %ASSEMBLY_FAMILY_NUMBER_WITH_LETTERS% | Assembly family number with letters. The letters run automatically from A to Z. If more letters are needed, Tekla Structures takes a second or even a third letter into use, for example AA or AAA. You can also define valid letters with the advanced option XS_VALID_CHARS_FOR_ASSEMBLY_FAMILY_POSITION_NUMBERS. |
| %ASSEMBLY_FAMILY_QUALIFIER% | Assembly family qualifier, defined by the family numbering criteria given in the Numbering Setup dialog box. |
| %ASSEMBLY_FAMILY_QUALIFIER_WITH_LETTERS% | Assembly family qualifier with letters. The letters run automatically from A to Z. If more letters are needed, Tekla |

| Option | Description |
|-------------------|--|
| | <p>Structures takes a second or even a third letter into use, for example AA or AAA.</p> <p>You can also define valid letters with the advanced option XS_VALID_CHARS_FOR_ASSEMBLY_FAMILY_QUALIFIER.</p> |
| %UDA: [uda_name]% | <p>User-defined attribute of the assembly or assembly main part. If the attribute is defined for the assembly, it will be used. If it is not defined, the main part attribute will be used. You can also define that only the user-defined attribute of the main part will be used, for example %UDA:MAINPART.USER_FIELD_1%.</p> |
| %TPL: [tpl_name]% | <p>Template attribute of the assembly or assembly main part, for example % TPL:PROJECT.NUMBER% .</p> |

Number of characters

You can define the number of characters by adding a period and the required number to the end of each option. For example

%ASSEMBLY_FAMILY_QUALIFIER_WITH_LETTERS.3% will result in three letters for every assembly, starting from AAA.

Example

If you set the advanced option to

```
XS_ASSEMBLY_FAMILY_POSITION_NUMBER_FORMAT_STRING=
%ASSEMBLY_PREFIX%/ASSEMBLY_FAMILY_NUMBER.3%-
%ASSEMBLY_FAMILY_QUALIFIER.3%
```

The result will be

A/001-001.

See also

[XS_VALID_CHARS_FOR_ASSEMBLY_FAMILY_POSITION_NUMBERS \(page 500\)](#)

[XS_VALID_CHARS_FOR_ASSEMBLY_FAMILY_QUALIFIER \(page 500\)](#)

2.59 XS_ASSEMBLY_MULTI_NUMBER_FORMAT_STRING

Category: Numbering

Use to base assembly numbers on drawing numbers. Use the following switches to define the contents of assembly marks. Use as many switches as you need, and enclose each one in percent symbols (%).

The available switches are:

| Switch | Description |
|--|---|
| %ASSEMBLY_MULTI_DRAWING_NUMBER% | Multidrawing name. |
| %ASSEMBLY_MULTI_DRAWING_POS% | Position of the assembly drawing inside the multidrawing. |
| %ASSEMBLY_PREFIX% | Assembly prefix in the model. |
| %ASSEMBLY_POS% | Assembly position number in the model. |
| Template fields | Enter TPL: followed by the name of any relevant template field. Enclose each name in percent symbols (%). For example, %TPL:PROJECT.NUMBER% NOTE: No template fields starting with DRAWING work for this advanced option, for example, DRAWING.TITLE1. If you use them in the value, Tekla Structures will replace the whole value string with the default value. |
| User-defined attributes that are defined in the objects.inp file | Enter UDA: followed by the name of any relevant user-defined attribute, exactly as it appears in the objects.inp file. For example, %UDA:MY_INFO_1% |

This advanced option is model specific and the setting is saved in the options database.

Example

To put the assembly multinumbers in the format multidrawing name + part prefix + position on multidrawing, set the advanced option as follows:

```
%ASSEMBLY_MULTI_DRAWING_NUMBER%%ASSEMBLY_PREFIX%
%ASSEMBLY_MULTI_DRAWING_POS%
```

This will create the assembly mark 10B1, where:

- 10 is the drawing number

- B is the assembly prefix
- 1 designates that it is the first assembly on the sheet.

See also

[XS_USE_MULTI_NUMBERING_FOR](#) (page 480)

[XS_PART_MULTI_NUMBER_FORMAT_STRING](#) (page 327)

[XS_CAST_UNIT_MULTI_NUMBER_FORMAT_STRING](#) (page 82)

2.60 XS_ASSEMBLY_POSITION_CODE_3D

Category

Templates and symbols

Set to `TRUE` to include Z orientation in assembly position codes.

The default value is `FALSE`.

This advanced option is model specific and the setting is saved in the options database.

2.61 XS_ASSEMBLY_POSITION_CODE_TOLERANCE

Category

Templates and symbols

Tolerance distance to use when identifying grid position code for assembly.

The default value is `500.0`.

This advanced option is model specific and the setting is saved in the options database.

2.62 XS_ASSEMBLY_POSITION_NEW_FORMAT

Category

Templates and Symbols

Use to define how the assembly position code is displayed in reports. Set to TRUE to use a format such as B1/C2 instead of B-C/1-2. The default value is FALSE.

This advanced option is model specific and the setting is saved in the options database.

2.63 XS_ASSEMBLY_POSITION_NUMBER_FORMAT_STRING

Category: Numbering

Use to define the contents of the assembly position number.

NOTE Do not change this advanced option after you have created single-part, assembly, or cast unit drawings, if you are using cloning. It may partially separate the drawings from the part they represent, causing the drawings to be flagged as deleted and other drawings to be cloned after the next numbering.

NOTE The advanced options XS_ASSEMBLY_POSITION_NUMBER_FORMAT_STRING and XS_PART_POSITION_NUMBER_FORMAT_STRING (page 328) override the advanced option XS_SWITCH_POS_NUMBERS_FOR (page 450). XS_SWITCH_POS_NUMBERS_FOR has no impact on assembly and/or part position numbers if you use XS_ASSEMBLY_POSITION_NUMBER_FORMAT_STRING and/or XS_PART_POSITION_NUMBER_FORMAT_STRING.

The options are:

| Option | Description |
|-----------------------------|---|
| %ASSEMBLY_PREFIX% | Assembly prefix, defined in the part properties in the property pane. |
| %ASSEMBLY_POS% | The running assembly position number, starting from the start number defined in the part properties in the property pane. |
| %ASSEMBLY_POS_WITH_LETTERS% | Same as above, but with letters. Uses letters A – Z by default, but you can also define valid letters with the advanced option XS_VALID_CHARS_FOR_ASSEMBLY_POSITION_NUMBERS. |
| %UDA: [uda_name] % | User-defined attribute of the assembly or assembly main part. If |

| Option | Description |
|-------------------|---|
| | the attribute is defined for the assembly, it will be used. If it is not defined, the main part attribute will be used. You can also define that only the user-defined attribute of the main part will be used, for example %UDA:MAINPART.USER_FIELD_1%. |
| %TPL: [tpl_name]% | Template attribute of the assembly or assembly main part, for example % TPL:PROJECT.NUMBER% . |

This advanced option is model specific and the setting is saved in the options database.

Number of characters in the assembly position number

You can define the number of characters by adding a period and the required number to the end of the options %ASSEMBLY_POS_WITH_LETTERS% and %ASSEMBLY_POS%. For example,%ASSEMBLY_POS_WITH_LETTERS.3% will result in three letters for every assembly, starting from AAA.

Example

If you set the advanced option to %ASSEMBLY_PREFIX%/ASSEMBLY_POS.3%, the result will be A/001.

See also

[XS_VALID_CHARS_FOR_ASSEMBLY_POSITION_NUMBERS \(page 501\)](#)

2.64 XS_ASSOCIATIVE_CHANGE_HIGHLIGHT_SIZE

Category

Dimensioning: General

Use to define the height of the change symbol around the points. The default value is 7.

This advanced option is model specific and the setting is saved in the options database.

See also

[XS_HIGHLIGHT_ASSOCIATIVE_DIMENSION_CHANGES \(page 258\)](#)

2.65 XS_ASSOCIATIVE_CHANGE_HIGHLIGHT_SYMBOL

Category

Dimensioning: General

Use to define the used associativity change symbol. The default value is `AssociativityAnchor@1` (a cloud).

This advanced option is model specific and the setting is saved in the options database.

See also

[XS_HIGHLIGHT_ASSOCIATIVE_DIMENSION_CHANGES](#) (page 258)

2.66 XS_ATTRIBUTE_FILE_EXCLUDE_LIST

Category

File Locations

Use this advanced option to exclude attribute files or reports from the user interface. For this advanced option control strings are given for controlling the access to attribute files or reports. If a control string is present anywhere in a filename of an attribute file or a report, the file or report becomes unavailable. Several control strings can be entered, and the values are case sensitive. Use semicolon (;) as a separator.

The default value is

```
TS_Report_Inquire;dgn_attribute_info;import_revision
```

- Enter the file name or a part of the file name that you want to exclude from the user interface as the value for the advanced option. For example, setting the advanced option to `_eng;_det` removes all the attribute files that include the string `_eng` or `_det` in their name from the user interface.
- Enter the name or a part of the name of the report you want to exclude from the **Create report** dialog box. For example, setting the advanced option to `_Part` hides the report `ts_Report_Inquire_Part.rpt` in the dialog box.

Example:

```
PROJ1_;PROJ2_;_TeamA;Team_Detailing
```

This advanced option is role specific. When the type **SYSTEM(ROLE)** is in use, the default value is used. When the type **MODEL(ROLE)** or **DRAWING(ROLE)** is in use, you can change the value, which is then the same for all users in the current model.

2.67 XS_AUTOCONNECTION_TOLERANCE

Category: Components

Use to set the size of the area that Tekla Structures searches for parts to connect with **AutoConnection**. Enter a value in millimeters, for example, 500. The default value is 0, which means that the connection is created only between colliding or adjacent parts.

This advanced option is model specific and the setting is saved in the options database.

2.68 XS_AUTOCONNECTION_USE_UDL

Category

Components

Set this advanced option to `TRUE` to switch on UDL calculation in **AutoConnection**. This calculates the maximum shear force allowed. The default value is `FALSE`.

This advanced option is model specific and the setting is saved in the options database.

2.69 XS_AUTODEFAULT_UDL_PERCENT

Category

Components

Use to set a default percentage for UDL calculation. The default value is 50.

In **AutoDefaults** Tekla Structures uses the percentage in the connection properties. If no percentage is given, Tekla Structures uses this value.

In **AutoConnection** only the default percentage is used. You switch UDL calculation on with the advanced option `XS_AUTOCONNECTION_USE_UDL`.

This advanced option is model specific and the setting is saved in the options database.

See also

[XS_AUTOCONNECTION_USE_UDL \(page 61\)](#)

2.70 XS_AUTOMATIC_NEW_MODEL_NAME

Category

Modeling Properties

Set this advanced option to `TRUE` (default) to have Tekla Structures suggest a name for a new model automatically in the **New** dialog box. The suggested name is `New model XX`, where `XX` is a running number.

If you set this advanced option to `FALSE`, the name is not suggested.

This advanced option is user specific and the setting is saved in `options.bin` under the user folder, for example, in `C:\Users\<user>\AppData\Local\Trimble\Tekla Structures\<version>\UserSettings`. Restart Tekla Structures to activate the new value.

2.71 XS_AUTOMATIC_USER_FEEDBACK_SAVING_INTERVAL

Category

Modeling Properties

Enter an integer to define the saving interval of the usage statistics information. The saving interval means the number of commands or interactions that the data collection observes before saving data to file. The value of the advanced option corresponds to the number of rows in the log file. The default value is 100.

The log file is called `UserFeedbackLog.txt`, and it is located in the `Logs` folder under the path defined with `XSUSERDATADIR` in `teklastructures.ini` file.

See also

[XS_AUTOMATIC_USER_FEEDBACK_SENDING_INTERVAL](#) (page 62)

[XSUSERDATADIR](#) (page 498)

2.72 XS_AUTOMATIC_USER_FEEDBACK_SENDING_INTERVAL

Category

Modeling Properties

Enter an integer to define the sending interval of usage statistics information. The value of the advanced option corresponds to the number of rows in the log file. The default value is 10000.

The log file is called `UserFeedbackLog.txt`, and it is located in the `Logs` folder under the path defined with **XSUSERDATADIR** in `teklastructures.ini` file.

This advanced option is user specific and the setting is saved in `options.bin` under the user folder, for example, in `C:\Users\\AppData\Local\Trimble\Tekla Structures\\UserSettings`. Restart Tekla Structures to activate the new value.

See also

[XS_AUTOMATIC_USER_FEEDBACK_SAVING_INTERVAL \(page 62\)](#)

[XSUSERDATADIR \(page 498\)](#)

2.73 XS_AUTOSAVE_DIRECTORY

Category

File Locations

Enter the path to the folder that contains the files that Tekla Structures saves automatically. The default value is `%XS_RUNPATH%\autosave\`.

If you do not define a path, Tekla Structures places autosave files in the current model folder.

This advanced option is user specific and the setting is saved in `options.bin` under the user folder, for example, in `C:\Users\\AppData\Local\Trimble\Tekla Structures\\UserSettings`. Restart Tekla Structures to activate the new value.

3 Advanced options - B

3.1 XS_BACKGROUND_COLOR1

Category: Model views

To have a gradient background color in model views, use the advanced options [XS_BACKGROUND_COLOR1 \(page 64\)](#), [XS_BACKGROUND_COLOR2 \(page 64\)](#), [XS_BACKGROUND_COLOR3 \(page 65\)](#), and [XS_BACKGROUND_COLOR4 \(page 65\)](#). With these advanced options you can control the color of each corner separately in a model view.

This advanced option controls the upper-left corner of the model view.

Define the color using RGB (Red Green Blue) values. The scale is from 0 to 1, and separate the numbers with spaces. If you want to use the traditional single-colored background, set the same value for all four background color advanced options. Reopen the view for the change to take effect.

The default value is 1.0 1.0 1.0. To use the default background color, leave the box empty.

This advanced option is user specific and the setting is saved in `options.bin` under the user folder, for example, in `C:\Users\\AppData\Local\Trimble\Tekla Structures\\UserSettings`.

Example

- Use 0.0 0.0 0.0 for black background.
- Use 1.0 1.0 1.0 for white background.

3.2 XS_BACKGROUND_COLOR2

Category: Model views

See [XS_BACKGROUND_COLOR1 \(page 64\)](#).

This advanced option controls the upper-right corner of the model view.

The default value is 1.0 1.0 1.0. To use the default background color, leave the box empty.

3.3 XS_BACKGROUND_COLOR3

Category: Model views

See [XS_BACKGROUND_COLOR1 \(page 64\)](#).

This advanced option controls the bottom-left corner of the model view.

The default value is 0.80 0.79 0.85. To use the default background color, leave the box empty.

3.4 XS_BACKGROUND_COLOR4

Category: Model views

See [XS_BACKGROUND_COLOR1 \(page 64\)](#).

This advanced option controls the bottom-right corner of the model view.

The default value is 0.80 0.79 0.85. To use the default background color, leave the box empty.

3.5 XS_BASE_LINE_WIDTH

Category

Plotting

Use this advanced option to specify the base line width for printed drawings. Enter the value in millimeters as decimal value. The default value is 0.01. The final line thicknesses in a printed drawing is the base line width multiplied by the pen thickness from the **Print Drawings** dialog box (or in the old printing, from the **Color** dialog box). For example, 25 will give a thickness of 0.25 mm.

TIP To control the accuracy of line thickness, use a small value for `XS_BASE_LINE_WIDTH` and a large number for the pen.

This advanced option also affects lines on the screen, if you set `XS_BASE_LINE_WIDTH_AFFECTS_SCREEN` to `TRUE`.

This advanced option is model specific and the setting is saved in the options database.

See also

[XS_BASE_LINE_WIDTH_AFFECTS_SCREEN](#) (page 66)

3.6 XS_BASE_LINE_WIDTH_AFFECTS_SCREEN

Category

Plotting

Set this advanced option to `TRUE`, if you want `XS_BASE_LINE_WIDTH` to affect line widths drawn on the screen.

Enter `FALSE` if you do not want `XS_BASE_LINE_WIDTH` to affect line widths on the screen.

The default value is `TRUE`.

This advanced option is model specific and the setting is saved in the options database.

See also

[XS_BASE_LINE_WIDTH](#) (page 65)

3.7 XS_BASICVIEW_HEIGHT

Category

Model View

Use to define the height of basic view windows. Enter the height in pixels. The default value is 375.

This advanced option is user specific and the setting is saved in `options.bin` under the user folder, for example, in `C:\Users\<user>\AppData\Local\Trimble\Tekla Structures\<version>\UserSettings`. Restart Tekla Structures to activate the new value.

Example

`XS_BASICVIEW_HEIGHT=570`

See also

[XS_BASICVIEW_POSITION_X \(page 67\)](#)

3.8 XS_BASICVIEW_POSITION_X

Category

Model View

Use to control the horizontal position of basic view windows on the screen. Enter the value in pixels. The default value is 100.

If the advanced option `XS_MDIBASICVIEWPARENT` is set, the origin for the position is the top left corner of the client area. Otherwise, the origin is the top left corner of the whole Tekla Structures window. Moving a toolbar also affects the size of the client area, because menus and toolbars are not part of it.

This advanced option is user specific and the setting is saved in `options.bin` under the user folder, for example, in `C:\Users\<user>\AppData\Local\Trimble\Tekla Structures\<version>\UserSettings`. Restart Tekla Structures to activate the new value.

See also

[XS_MDIBASICVIEWPARENT \(page 301\)](#)

3.9 XS_BASICVIEW_POSITION_Y

Category

Model View

Use to control the vertical position of basic view windows on the screen. Enter the value in pixels. The default value is 20.

This advanced option is user specific and the setting is saved in `options.bin` under the user folder, for example, in `C:\Users\<user>\AppData\Local\Trimble\Tekla Structures\<version>\UserSettings`. Restart Tekla Structures to activate the new value.

See also

[XS_BASICVIEW_POSITION_X \(page 67\)](#)

3.10 XS_BASICVIEW_WIDTH

Category

Model view

Use to define the width of basic view windows. Enter the width in pixels, for example, 570. The default value is 375.

This advanced option is user specific and the setting is saved in `options.bin` under the user folder, for example, in `C:\Users\\AppData\Local\Trimble\Tekla Structures\\UserSettings`. Restart Tekla Structures to activate the new value.

See also

[XS_BASICVIEW_POSITION_X](#) (page 67)

3.11 XS_BEVEL_DIMENSIONS_FOR_PROFILES_ONLY

Category

Dimensioning: Parts

Use to define whether to show bevel dimensions only for profiles.

If you set the advanced option to `TRUE`, bevel dimensions are shown only for profiles

If you set the advanced option to `FALSE` (default), bevel dimensions are shown always.

This advanced option is model specific and the setting is saved in the options database.

3.12 XSBIN

This advanced option must be set in an initialization (.ini) file.

This advanced option is system specific and is read from `teklastructures.ini`. Generally, there is no need to modify system-specific settings. Do not modify them if you are not an administrator.

This advanced option defines the location of the Tekla Structures `bin` folder.

3.13 XS_BLACK_DRAWING_BACKGROUND

Category: Drawing views

Set to `TRUE` to have a black background and colored lines in drawings. If you want to have white background and colored lines, enter `FALSE` (default).

This advanced option only affects the **Color** mode, not the **Black and White** or **Gray Scale** mode.

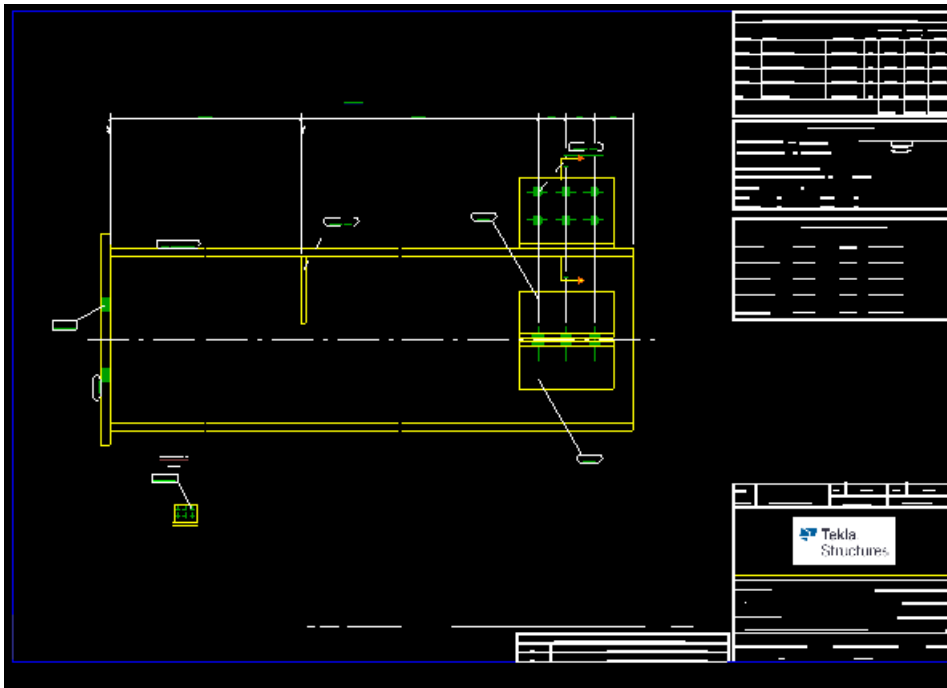

This advanced option is user specific and the setting is saved in `options.bin` under the user folder, for example, in `C:\Users\\AppData\Local\Trimble\Tekla Structures\\UserSettings`.

Note that you do not need to restart to activate the changed value, just reopen the drawing.

See also

Colors in drawings

[XS_USE_COLOR_DRAWINGS \(page 471\)](#)

3.14 XS_BOLT_DUPLICATE_IGNORE

Category: Numbering

NOTE Do not use this advanced option in new models. This advanced option was a temporary solution that has been replaced with a more comprehensive option.

Instead of the `XS_BOLT_DUPLICATE_...` advanced options, use the **No hole** option for **Special hole type** in the **Bolt** properties.

If necessary in existing models, use this advanced option to define whether duplicate bolt holes in the same location, or within a [tolerance \(page 70\)](#), in a part are ignored in part numbering, and in drawings and NC files.

The default value is `FALSE`.

If this advanced option is set to `TRUE`, the duplicate bolt holes are ignored in part numbering, and in drawings and NC files.

You can use this advanced option when only some and possibly a different set of the holes in otherwise identical parts will be used for bolting on site. In this way identical parts can be used in different conditions in the structure.

The size of the duplicate holes is not taken into consideration, only the location, so holes of different size are considered duplicates if they are in the same location.

If there are overlapping holes within the tolerance, the hole without a bolt is taken into account, and the hole created by an actual bolt is ignored.

NOTE It is not recommended to change this advanced option during a project, but if you do so, you must carry out full numbering.

This advanced option is model specific and the setting is saved in the options database.

See also

[XS_BOLT_DUPLICATE_TOLERANCE \(page 70\)](#)

3.15 XS_BOLT_DUPLICATE_TOLERANCE

Category: Numbering

NOTE Do not use this advanced option in new models. This advanced option was part of a temporary solution that has been replaced with a more comprehensive option.

Instead of the `XS_BOLT_DUPLICATE_...` advanced options, use the **No hole** option for **Special hole type** in the **Bolt** properties.

If necessary in existing models, when [XS_BOLT_DUPLICATE_IGNORE \(page 69\)](#) is set to `TRUE`, use `XS_BOLT_DUPLICATE_TOLERANCE` to set the location tolerance that defines which bolt holes are considered duplicates and will therefore be ignored in part numbering.

The default value for the tolerance is 3 mm.

NOTE It is not recommended to change this advanced option during a project, but if you do so, you must carry out full numbering.

This advanced option is model specific and the setting is saved in the options database.

3.16 XS_BOLT_LENGTH_EPSILON

Category: Modeling properties

Use to round bolt length.

Tekla Structures calculates bolt length using material thickness. To avoid having several bolt lengths where material thickness only differs slightly, set this advanced option to a positive or negative value. This value is multiplied by two and the result is subtracted from the material thickness in bolt length calculation. Enter the value in millimeters (all environments). Typical values are 0.001–0.5. The default value is 0.001.

This advanced option is model specific and the setting is saved in the options database.

3.17 XS_BOLT_MARK_DIAMETER_PREFIX

Category

Marking: Bolts

Use this advanced option to specify a prefix for bolt mark diameter. The possible values are `NONE` or any string.

This advanced option is model specific and the setting is saved in the options database.

Example

For a bolt group consisting of three 20 mm diameter bolts:

- If you do not give any value, result is
3*M20
- If you set `XS_BOLT_MARK_DIAMETER_PREFIX` to `NONE`, the result is
3*20
- If you set `XS_BOLT_MARK_DIAMETER_PREFIX` to `D`, the result is
3*D20

3.18 XS_BOLT_MARK_IS_ALWAYS_VISIBLE

Category

Marking: Bolts

Set this advanced option to `TRUE` to show the bolt marks of bolts hidden from views by other objects. The bolt marks are displayed with solid leader lines and frames. If you set it to `FALSE` (default), the bolt marks of hidden bolts are displayed with dashed leader lines and frames. This advanced option affects all drawing types.

This advanced option is model specific and the setting is saved in the options database.

3.19 XS_BOLT_MARK_IS_ALWAYS_VISIBLE_IN_GA

Category

Marking: Bolts

Set this advanced option to `TRUE` to show the bolt marks of bolts hidden from views by other objects. The bolt marks are displayed with solid leader lines and frames. If you set it to `FALSE` (default), the bolt marks of hidden bolts are displayed with dashed leader lines and frames. This advanced only affects general arrangement drawings.

NOTE If you have set the advanced option

`XS_BOLT_MARK_IS_ALWAYS_VISIBLE` to `TRUE`, the bolt marks are always displayed with solid lines even if you set `XS_BOLT_MARK_IS_ALWAYS_VISIBLE_IN_GA` to `FALSE`.

This advanced option is model specific and the setting is saved in the options database.

3.20 XS_BOLT_MARK_STRING_FOR_SIZE

Category

Marking: bolts

Use to define the contents of the **Size** element in bolt marks. For example, to have the bolt number and the hole diameter in the mark, enter

`%BOLT_NUMBER%*D%HOLE.DIAMETER%`.

This advanced option is only used when there is a bolt and the hole is a normal one.

The advanced options `XS_SHOP_BOLT_MARK_STRING_FOR_SIZE` and `XS_SITE_BOLT_MARK_STRING_FOR_SIZE` override this setting.

You can use any combination of text and the following options as the value for this advanced option. You can use the options in any order, and make calculations.

- BOLT_NUMBER
- DIAMETER
- LENGTH
- HOLE.DIAMETER
- LONG_HOLE_X
- LONG_HOLE_Y
- LONGHOLE_MIN (the shorter of the slotted hole dimensions)
- LONGHOLE_MAX (the longer of the slotted hole dimensions)
- BOLT_STANDARD
- BOLT_MATERIAL
- BOLT_ASSEMBLY_TYPE
- BOLT_COUNTERSUNK
- BOLT_SHORT_NAME
- BOLT_FULL_NAME

Enclose each option in % characters.

Note that if you are defining this advanced option in an `.ini` file, use double percent signs around the options. For example, `%%BOLT_NUMBER%%*D%
%HOLE.DIAMETER%%`.

To use special characters, enter a backslash (\) followed by an ASCII number.

With length-type options, but not in calculations, you can specify the number of decimals. For example, `HOLE.DIAMETER.2` shows (tapped) hole diameters with two decimals.

This advanced option is model specific and the setting is saved in the options database.

See also

[XS_SITE_BOLT_MARK_STRING_FOR_SIZE \(page 432\)](#)

[XS_SHOP_BOLT_MARK_STRING_FOR_SIZE \(page 405\)](#)

3.21 XS_BOLT_MARK_STRING_FOR_SIZE_IN_GA

Category

Marking: Bolts

Use to define the contents of the size element in bolt marks in general arrangement drawings. If you have not set the advanced options `XS_SHOP_BOLT_MARK_STRING_FOR_SIZE_IN_GA` or `XS_SITE_BOLT_MARK_STRING_FOR_SIZE_IN_GA`, then this advanced option is used.

This advanced option is only used when there is a bolt and the hole is a normal one.

You can use any combination of text and the following options as the value for this advanced option. You can use the options in any order, and make calculations.

- BOLT_NUMBER
- DIAMETER
- LENGTH
- HOLE.DIAMETER
- LONG_HOLE_X
- LONG_HOLE_Y
- LONGHOLE_MIN (the shorter of the slotted hole dimensions)
- LONGHOLE_MAX (the longer of the slotted hole dimensions)

- BOLT_STANDARD
- BOLT_MATERIAL
- BOLT_ASSEMBLY_TYPE
- BOLT_COUNTERSUNK
- BOLT_SHORT_NAME
- BOLT_FULL_NAME

Enclose each option in % characters.

Note that if you are defining this advanced option in an `.ini` file, use double percent signs around the options. For example, `%%BOLT_NUMBER%%*D%
%HOLE.DIAMETER%%`.

To use special characters, enter a backslash (\) followed by an ASCII number.

With length-type options, but not in calculations, you can specify the number of decimals. For example, `HOLE.DIAMETER.2` shows (tapped) hole diameters with two decimals.

This advanced option is model specific and the setting is saved in the options database.

See also

[XS_SHOP_BOLT_MARK_STRING_FOR_SIZE_IN_GA \(page 406\)](#)

[XS_SITE_BOLT_MARK_STRING_FOR_SIZE_IN_GA \(page 433\)](#)

3.22 XS_BOLT_POSITION_TO_MIN_AND_MAX_POINT

Category: Dimensioning - bolts

Set this advanced option to `TRUE` to create minimum and maximum position dimensions for bolts. If you do not want to create minimum and maximum position dimensions for bolts, set it to `FALSE` (default).

This advanced option is model specific and the setting is saved in the options database.

The examples below show a maximum bolt dimension of 40:

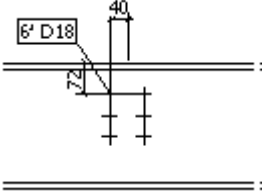
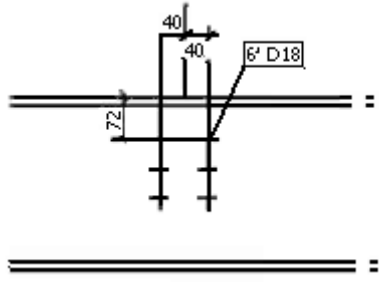
| Setting | Example |
|--|--|
| Before setting the advanced option. |  |
| After setting the advanced option to TRUE. |  |

3.23 XS_BOLT_REPRESENTATION_SYMBOL_AXIS_POSITION_AS_EXACT_SOLID

Category: Drawing properties

If you set the advanced option

`XS_BOLT_REPRESENTATION_SYMBOL_AXIS_POSITION_AS_EXACT_SOLID` to **TRUE**, all bolt axis representations set to **Symbol** are presented in the same position as with **Exact solid**.

The default value is **TRUE**.

This advanced option is model specific and the setting is saved in the options database.

Symbol representation when the advanced option is set to **FALSE**:

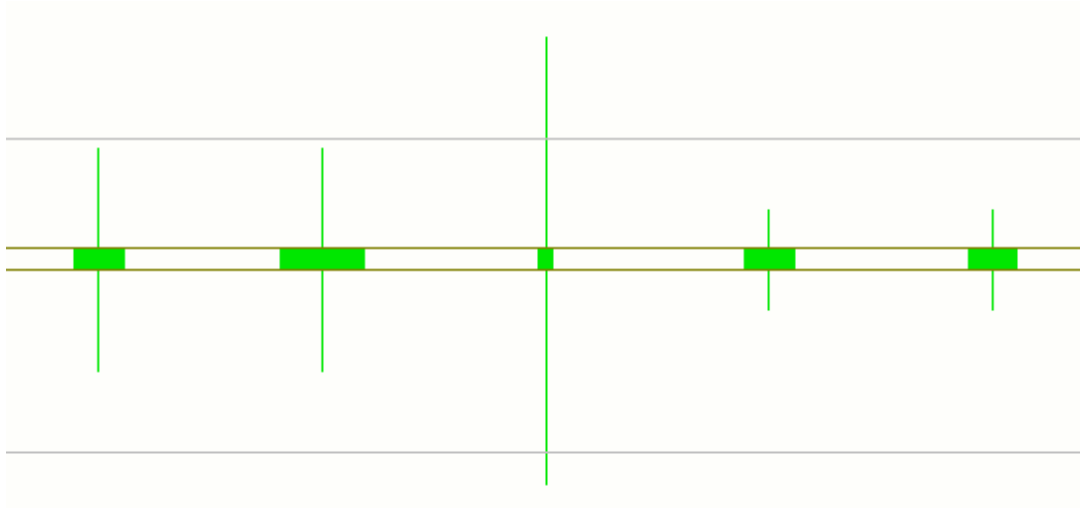

Symbol representation when the advanced option is set to `TRUE`:

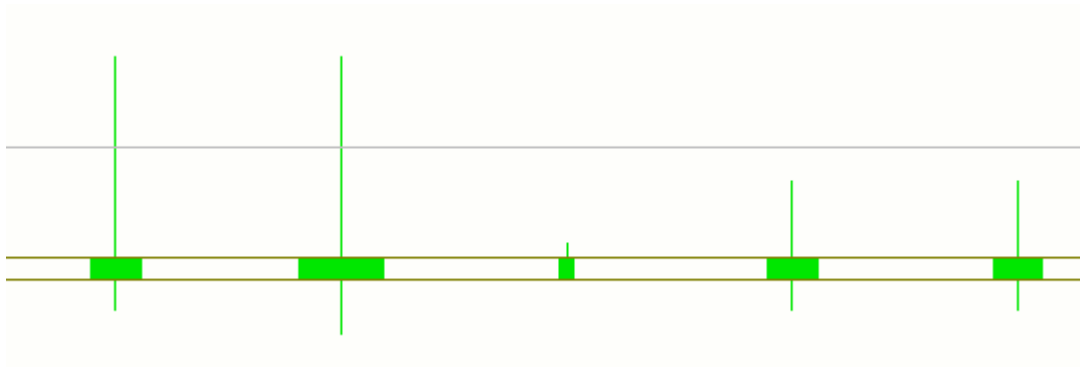

3.24 XS_BOLT_REPRESENTATION_USE_POSITIVE_CUT_LENGTH

Category

Drawing Properties

Set this advanced option to `TRUE` to create bolt holes in the drawing instead of sticks when the cut length is negative. `FALSE` is the default value.



This advanced option is model specific and the setting is saved in the options database.

3.25 XS_BOLTS_PERPENDICULAR_TO_PART_PLANE_IN_NC

Category

CNC

Set this advanced option to `TRUE` (default) to dimension bolts perpendicular to part plane in NC files. If you do not want to dimension the bolts, set it to `FALSE`.

This advanced option is model specific and the setting is saved in the options database.

4 Advanced options - C

4.1 XS_CALCULATE_POLYBEAM_LENGTH_ALONG_REFERENCE_LINE

Category: Dimensioning - unfolding

Use this advanced option to calculate polybeam length along the reference line instead of the centerline. By default, Tekla Structures measures polybeam length along the centerline of the beam, regardless of the **Position in plane** values of the beam.

Set this advanced option to `TRUE` to calculate polybeam length along the reference line. Set it to `FALSE` (default) to calculate along the centerline.

When this advanced option is set, Tekla Structures ignores all unfolding parameters defined in the `unfold_corner_ratios.inp` file. However, this only affects polybeams with straight sections. The length of polybeams with curved chamfers is always controlled using `unfold_corner_ratios.inp`.

This advanced option is model specific and the setting is saved in the options database.

NOTE The centerline option is always a safe alternative, because other modifications do not impact on it. For example, if you calculate length using the reference line and you have used offsets to move the beam, the result may not be the true length of the beam.

NOTE When [XS_USE_OLD_POLYBEAM_CALCULATION \(page 485\)](#) is set to `TRUE`, this advanced option is not used, even though results might be the same in most cases. To obtain reliable results, especially for Net Length, we recommend that you do not set `XS_USE_OLD_POLYBEAM_LENGTH_CALCULATION` to `TRUE`.

4.2 XS_CALCULATE_POUR_UNITS_ON_SHARING

Category: Multi-user

When this advanced option is set to `FALSE` (which is the default value), each user has to run the **Calculate pour units** command in their local version of the shared model to update the pour units.

If this advanced option is set to `TRUE`, pour units are automatically calculated and up to date in the shared model after read in and write out.

This advanced option is model specific and the setting is saved in the options database.

4.3 XS_CAST_UNIT_FAMILY_POSITION_NUMBER_FORMAT_STRING

Category

Numbering

Use to define the contents of the cast unit family position number. For example, instead of DT1-1, DT1-2, you can define the numbering as DT1-A, DT1-B.

To get this result, set the advanced option as follows:

```
%CAST_UNIT_PREFIX%%CAST_UNIT_FAMILY_NUMBER%-  
%CAST_UNIT_FAMILY_QUALIFIER_WITH_LETTERS%
```

Use the following options to define the contents of family position numbers. Use as many options as you need, and enclose each one in percent symbols (%).

| Option | Description |
|---------------------------|---|
| %CAST_UNIT_PREFIX% | Cast unit prefix, defined in the part properties in the property pane. |
| %CAST_UNIT_POS% | The running cast unit position number, starting from the start number defined in the part properties in the property pane. |
| %CAST_UNIT_FAMILY_NUMBER% | Cast unit family number, defined by the start number (in part properties in the property pane) and the final position in that numbering series. |

| Option | Description |
|---|---|
| %CAST_UNIT_FAMILY_NUMBER_WITH_LETTERS% | <p>Cast unit family number with letters. The letters run automatically from A to Z. If more letters are needed, Tekla Structures takes a second or even a third letter into use, for example AA or AAA.</p> <p>You can also define valid letters with the advanced option XS_VALID_CHARS_FOR_ASSEMBLY_FAMILY_POSITION_NUMBERS.</p> |
| %CAST_UNIT_FAMILY_QUALIFIER% | <p>Cast unit family qualifier, defined by the family numbering criteria given in the Numbering Setup dialog box.</p> |
| %CAST_UNIT_FAMILY_QUALIFIER_WITH_LETTERS% | <p>Cast unit family qualifier with letters. The letters run automatically from A to Z. If more letters are needed, Tekla Structures takes a second or even a third letter into use, for example AA or AAA.</p> <p>You can also define valid letters with the advanced option XS_VALID_CHARS_FOR_ASSEMBLY_FAMILY_QUALIFIER.</p> |
| %UDA: [uda_name] % | <p>User-defined attribute of the cast unit or cast unit main part. If the attribute is defined for the cast unit, it will be used. If it is not defined, the main part attribute will be used. You can also define that only the user-defined attribute of the main part will be used, for example %UDA:MAINPART.USER_FIELD_1%.</p> |
| %TPL: [tpl_name] % | <p>Template attribute of the cast unit or cast unit main part, for example %TPL:PROJECT.NUMBER%.</p> |

This advanced option is model specific and the setting is saved in the options database.

Number of characters

You can define the number of characters by adding a period and the required number to the end of each option. For example

%CAST_UNIT_FAMILY_QUALIFIER_WITH_LETTERS.3% will result in three letters for every cast unit, starting from AAA.

Example

If you set the advanced option to

```
%CAST_UNIT_PREFIX%/%CAST_UNIT_FAMILY_NUMBER.3%-  
%CAST_UNIT_FAMILY_QUALIFIER.3%
```

The result will be

A/001-001.

See also

[XS_VALID_CHARS_FOR_ASSEMBLY_FAMILY_QUALIFIER \(page 500\)](#)

[XS_VALID_CHARS_FOR_ASSEMBLY_FAMILY_POSITION_NUMBERS \(page 500\)](#)

4.4 XS_CAST_UNIT_MULTI_NUMBER_FORMAT_STRING

Category: Numbering

Use to base cast unit numbers on drawing numbers. Use the following switches to define the contents of cast unit marks. Use as many switches as you need, and enclose each one in percent symbols (%).

The available switches are:

| Switch | Description |
|----------------------------------|---|
| %CAST_UNIT_MULTI_DRAWING_NUMBER% | Multidrawing name. |
| %CAST_UNIT_MULTI_DRAWING_POS% | Position of the cast unit drawing inside the multidrawing. |
| %CAST_UNIT_PREFIXX% | Cast unit prefix in the model. |
| %CAST_UNIT_POS% | Cast unit position number in the model. |
| Template fields | Enter TPL: followed by the name of any relevant template field. Enclose each name in percent symbols (%). For example, %TPL:PROJECT.NUMBER% NOTE: No template fields starting with DRAWING work for this advanced option, for example, DRAWING.TITLE1. If you use them in the value, Tekla Structures will replace the whole value string with the default value. |

| Switch | Description |
|---|--|
| User-defined attributes that are defined in the <code>objects.inp</code> file | Enter <code>UDA:</code> followed by the name of any relevant user-defined attribute, exactly as it appears in the <code>objects.inp</code> file. For example, <code>%UDA:MY_INFO_1%</code> |

This advanced option is model specific and the setting is saved in the options database.

Example

To put the cast unit multinumbers in the format multidrawing name + part prefix + position on multidrawing, set the advanced option as follows:

```
%CAST_UNIT_MULTI_DRAWING_NUMBER%%CAST_UNIT_PREFIX%
%CAST_UNIT_MULTI_DRAWING_POS%
```

This will create the cast unit mark 10B1, where:

- 10 is the drawing number
- B is the cast unit prefix
- 1 designates that it is the first cast unit on the sheet.

See also

[XS_USE_MULTI_NUMBERING_FOR](#) (page 480)

[XS_PART_MULTI_NUMBER_FORMAT_STRING](#) (page 327)

[XS_ASSEMBLY_MULTI_NUMBER_FORMAT_STRING](#) (page 55)

4.5 XS_CAST_UNIT_POSITION_NUMBER_FORMAT_STRING

Category: Numbering

Use to define the contents of the cast unit position number.

NOTE Do not change this advanced option after you have created single-part, assembly, or cast unit drawings, if you are using cloning. It may partially separate the drawings from the part they represent, causing the drawings to be flagged as deleted and other drawings to be cloned after the next numbering.

The options are:

| Option | Description |
|---------------------------------|--|
| <code>%CAST_UNIT_PREFIX%</code> | Cast unit prefix, defined in the part properties in the property pane. |

| Option | Description |
|------------------------------|---|
| %CAST_UNIT_POS% | The running cast unit position number, starting from the start number defined in the part properties in the property pane. |
| %CAST_UNIT_POS_WITH_LETTERS% | Same as above, but with letters. Uses letters A – Z by default, but you can also define valid letters with the advanced option XS_VALID_CHARS_FOR_ASSEMBLY_POSITION_NUMBERS |
| %UDA: [uda_name]% | User-defined attribute of the cast unit or cast unit main part. If the attribute is defined for the cast unit, it will be used. If it is not defined, the main part attribute will be used. You can also define that only the user-defined attribute of the main part will be used, for example %UDA:MAINPART.USER_FIELD_1%. |
| %TPL: [tpl_name]% | Template attribute of the cast unit or cast unit main part, for example % TPL: PROJECT.NUMBER%. |

This advanced option is model specific and the setting is saved in the options database.

Number of characters

You can define the number of characters by adding a period and the required number to the end of the options %CAST_UNIT_POS% and %CAST_UNIT_POS_WITH_LETTERS%. For example, %CAST_UNIT_POS_WITH_LETTERS.3% will result in three letters for every cast unit, starting from AAA.

Example

If you set the advanced option to %CAST_UNIT_PREFIX%/ %CAST_UNIT_POS.3%, the result will be A/001.

4.6 XS_CENTER_LINE_TYPE

Category: Drawing properties

Use this advanced option to change the line type of the part center lines in drawings. Enter an integer value from 1 to 7. To see the center line type change, close the drawing and open it again.

You can select whether to show the center line in part properties.



| Value | Description |
|-------|--|
| 1 | Solid line |
| 2 - 7 | Dotted lines. The default value is 4 (dash-and-dot line). |

If you enter a value that is lower than 1 or higher than 7, Tekla Structures uses the default value 4.

TIP To see what the line types look like, see the **Hidden lines** > **Type** options on the **Appearance** tab in **Part Properties**.

This advanced option is model specific and the setting is saved in the options database.

4.7 XS_CENTER_TO_CENTER_DISTANCE_IN_ONE_PART_STRING

Category

Marking: Bolts

Sets the format of the element **Center-to-center distance** in bolt marks, when the bolts are in the same part, for example, in a column or beam flange. Use to define gage information in the bolt mark in the following way:

- Use the switch %VALUE% for the numeric value of a gage.
- You can add text and the option in any order, for example, %VALUE% GAGE or GAGE %VALUE%.
- If %VALUE% is missing, Tekla Structures adds the center-to-center distance to the end of the string.

- If this advanced option is not set, only %VALUE% is used.
- If Tekla Structures cannot calculate the gage, nothing is added in the mark.
- The default value value is $GAGE = \%VALUE\%$.

This advanced option is model specific and the setting is saved in the options database.

Example

There is a symmetrical bolt group in a beam flange. The value for gage is 10.

| In the Advanced Options dialog box | In bolt mark |
|------------------------------------|--------------|
| GAGE = %VALUE% | GAGE = 10 |

4.8 XS_CENTER_TO_CENTER_DISTANCE_IN_TWO_PARTS_STRING

Category

Marking: Bolts

Sets the format of the element **Center-to-center distance** in bolt marks where there are two parts.

The default value is $C/C = \%VALUE\%$.

This advanced option is model specific and the setting is saved in the options database.

Example

There is a symmetrical bolt group in two clip angles. The center-to-center distance is 10.

| In the Advanced Options dialog box | In bolt mark |
|------------------------------------|--------------|
| c/c = %VALUE% | c/c = 10 |

See also

[XS_CENTER_TO_CENTER_DISTANCE_IN_ONE_PART_STRING](#) (page 85)

4.9 XS_CHAMFER_ACCURACY_FACTOR

Category: Speed and accuracy

Use this advanced option to define the number of points used for chamfers. Use lower values to increase the number of points used to construct the chamfer, thus making the curved chamfer smoother. Use larger values to decrease the number of points used to construct the chamfer, thus making the curved chamfer less smoother.

The default value is 4 . 0.

Restart Tekla Structures after changing the value to activate the new setting.

In the example below, the value is 16.

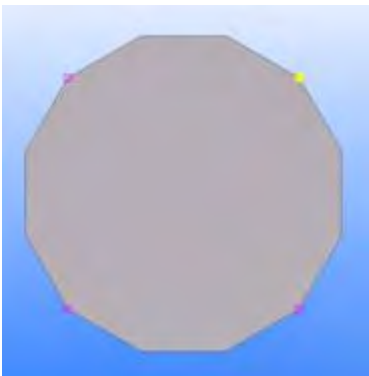

In the example below, the value is 1.



The minimum value is 0.1.

Click the links below to find out more:

[Round chamfers does not appear round in model](#)

[Chamfer accuracy for polybeams and contour plates](#)

4.10 XS_CHAMFER_DISPLAY_LENGTH_FACTOR

Category: Model views

Use to adjust chamfer length. Tekla Structures calculates plate chamfer length from the plate side length using the following formula:

`XS_CHAMFER_DISPLAY_LENGTH_FACTOR * plate side length`. By default this factor is 0.08.

This advanced option is user specific and the setting is saved in `options.bin` under the user folder, for example, in `C:\Users\\AppData\Local\Trimble\Tekla Structures\\UserSettings`.

4.11 XS_CHANGE_DRAGGED_DIMENSIONS_TO_FIXED

Category

Drawing Properties

Use to define whether dimensions have fixed placing when you drag them away from their original locations. When set to `TRUE`, dimension placing uses fixed placing routine instead of free placing. `FALSE` keeps the placing free.

The default value is `TRUE`.

Note that this advanced option does not affect dimension type **Curved dimension, radial reference lines**.

This advanced option is user specific and the setting is saved in `options.bin` under the user folder, for example, in `C:\Users\\AppData\Local\Trimble\Tekla Structures\\UserSettings`. Restart Tekla Structures to activate the new value.

4.12 XS_CHANGE_DRAGGED_MARKS_TO_FIXED

Category

Drawing Properties

Use to define whether part, bolt and reinforcement marks have fixed placing when you drag them away from their original locations. When set to `TRUE`, mark placing uses fixed placing routine instead of free placing.

The default value is `TRUE`.

This advanced option is user specific and the setting is saved in `options.bin` under the user folder, for example, in `C:\Users\\AppData\Local`

`\Trimble\Tekla Structures\<version>\UserSettings`. Restart Tekla Structures to activate the new value.

4.13 XS_CHANGE_DRAGGED_NOTES_TO_FIXED

Category

Drawing Properties

Use to define whether associative notes have fixed placing when you drag them away from their original locations. When set to `TRUE`, associative notes placing uses fixed placing routine instead of free placing. `FALSE` keeps the placing free.

The default value is `TRUE`.

This advanced option is user specific and the setting is saved in `options.bin` under the user folder, for example, in `C:\Users\<user>\AppData\Local\Trimble\Tekla Structures\<version>\UserSettings`. Restart Tekla Structures to activate the new value.

4.14 XS_CHANGE_DRAGGED_TEXTS_TO_FIXED

Category

Drawing Properties

Use to define whether texts have fixed placing when you drag them away from their original locations. When set to `TRUE`, text uses fixed placing routine instead of free placing. The default value is `TRUE`.

This advanced option is user specific and the setting is saved in `options.bin` under the user folder, for example, in `C:\Users\<user>\AppData\Local\Trimble\Tekla Structures\<version>\UserSettings`. Restart Tekla Structures to activate the new value.

4.15 XS_CHANGE_DRAGGED_VIEWS_TO_FIXED

Category

Drawing Properties

Use to define whether views have fixed placing when you drag them away from their original locations. When set to `TRUE`, view placing uses fixed placing

routine instead of free placing. If you set this advanced option to `FALSE`, fixed placing is not used. The default value is `TRUE`.

This advanced option is user specific and the setting is saved in `options.bin` under the user folder, for example, in `C:\Users\\AppData\Local\Trimble\Tekla Structures\\UserSettings`. Restart Tekla Structures to activate the new value.

4.16 XS_CHANGE_MARK_ASTERISK_TO

Category

Marking: parts

Use to specify a symbol to replace the asterisk character (*) in bolt marks and the size elements of part marks. The default value is asterisk (*).

This advanced option is model specific and the setting is saved in the options database.

NOTE You cannot use this advanced option to change the asterisk character in profile strings (e.g. PL10*100).

Example

```
XS_CHANGE_MARK_ASTERISK_TO=X
```

4.17 XS_CHANGE_WORKAREA_WHEN_MODIFYING_VIEW_DEPTH

Category

Model view

Makes working with reference files easier. Objects such as parts and reference files outside the work area are not visible, even when they are within the view depth range.

Set to `TRUE` (default) to automatically adjust the work area when you change the view depth.

4.18 XS_CHECK_BOLT_EDGE_DISTANCE_ALWAYS

Category

Modeling Properties

Use this advanced option to select whether to check the bolt edge distance. Set to `TRUE` to always check the bolt edge distance and to `FALSE` to check it only when there are bolts in the object (the check is not done if there is only a hole).

The default value is `TRUE`.

This advanced option is user specific and the setting is saved in `options.bin` under the user folder, for example, in `C:\Users\\AppData\Local\Trimble\Tekla Structures\\UserSettings`. Restart Tekla Structures to activate the new value.

4.19 XS_CHECK_FLAT_LENGTH_ALSO

Category: Plate work

Set this advanced option to `TRUE` (default) to check plate length and plate width, and then compare those with the possible dimensions for flat bars in `fltprops.inp`.

If you set this advanced option to `FALSE`, Tekla Structures only checks the plate width.

This advanced option is model specific and the setting is saved in the options database.

4.20 XS_CHECK_TRIANGLE_TEXT_SIZE

Category

Dimensioning: General

Set this advanced option to `TRUE` to size the triangle to fit text in bevel dimensions. The default value is `FALSE`.

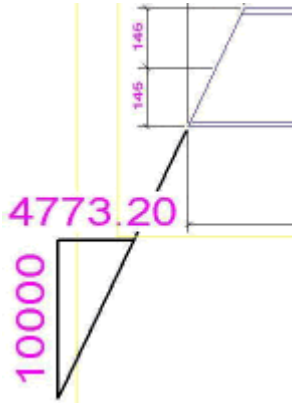

This advanced option is model specific and the setting is saved in the options database.

To define the angle symbol size, use the advanced option `XS_ANGLE_DIMENSION_SYMBOL_SIZE_FACTOR`.

NOTE Using advanced option

`XS_ANGLE_DIMENSION_SYMBOL_SIZE_FACTOR` will disable advanced option `XS_CHECK_TRIANGLE_TEXT_SIZE`.

See also

[XS_ANGLE_DIMENSION_SYMBOL_SIZE_FACTOR \(page 50\)](#)

4.21 XS_CHORD_TOLERANCE_FOR_SMALL_TUBE_SEGMENTS

Category

Speed and Accuracy

Use this advanced option to define the chord tolerance for round tubes smaller than or equal to the limit set by the advanced option `XS_CHORD_TOLERANCE_SMALL_TUBE_SIZE_LIMIT`. Enter the value in millimeters. The default value is 1.0.

Re-open the model to activate the new value.

NOTE Do not change the chord tolerance settings during a project. Changing them automatically recreates the tubular sections in the model when you restart Tekla Structures, resulting in slightly different solid objects, which may affect numbering.

See also

[XS_CHORD_TOLERANCE_SMALL_TUBE_SIZE_LIMIT \(page 93\)](#)

[XS_CHORD_TOLERANCE_FOR_TUBE_SEGMENTS \(page 93\)](#)

4.22 XS_CHORD_TOLERANCE_FOR_TUBE_SEGMENTS

Category

Speed and Accuracy

Use this advanced option to define the chord tolerance for round tubes larger than the limit set by the advanced option

`XS_CHORD_TOLERANCE_SMALL_TUBE_SIZE_LIMIT`. Enter the value in millimeters. The default value is 1.0.

Re-open the model to activate the new value.

Chord tolerance

Chord tolerance is the maximum difference between a straight segment used to display a tubular section in model views and the actual tubular section:

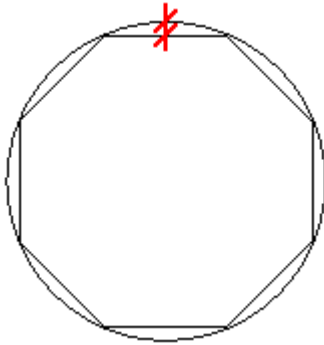

NOTE Do not change the chord tolerance settings during a project. Changing them automatically recreates the tubular sections in the model when you restart Tekla Structures, resulting in slightly different solid objects, which may affect numbering.

See also

[XS_CHORD_TOLERANCE_SMALL_TUBE_SIZE_LIMIT](#) (page 93)

[XS_CHORD_TOLERANCE_FOR_SMALL_TUBE_SEGMENTS](#) (page 92)

4.23 XS_CHORD_TOLERANCE_SMALL_TUBE_SIZE_LIMIT

Category

Speed and Accuracy

Use this advanced option to define the limit that determines whether a tube is considered small when calculating the chord tolerance. The value is compared to the diameter of the profile. Enter the value in millimeters. The default value is 50.0.

Re-open the model to activate the new value.

NOTE Do not change the chord tolerance settings during a project. Changing them automatically recreates the tubular sections in the model when you restart Tekla Structures, resulting in slightly different solid objects, which may affect numbering.

See also

[XS_CHORD_TOLERANCE_FOR_TUBE_SEGMENTS \(page 93\)](#)

[XS_CHORD_TOLERANCE_FOR_SMALL_TUBE_SEGMENTS \(page 92\)](#)

4.24 XS_CIS_DEP1_DATABASE_NAME

Category

Export

Use to define the name of the temporary database used in CIMsteel transfers.

This advanced option is system specific and is read from environment files. Generally, there is no need to modify system-specific settings. Do not modify them if you are not an administrator.

4.25 XS_CIS_DEP1_DATABASE_PASSW

Category

Export

Use to define the password for the temporary database used in CIMsteel transfers.

This advanced option is system specific and is read from environment files. Generally, there is no need to modify system-specific settings. Do not modify them if you are not an administrator.

4.26 XS_CIS_DEP1_DATABASE_PATH

Category

Export

Use to define a path to the temporary database that Tekla Structures creates while converting a model from/to CIMsteel STEP format.

This advanced option is system specific and is read from environment files. Generally, there is no need to modify system-specific settings. Do not modify them if you are not an administrator.

4.27 XS_CIS_DEP1_EXPRESS_FILE

Category

This advanced option must be set in an initialization (.ini) file.

Use this advanced option to specify the name of the EXPRESS file located in the system folder. The EXPRESS file describes the CIMsteel DEP1 logical product model. It is used when you convert a Tekla Structures model to/from CIMsteel DEP1 STEP format.

This advanced option is user specific and the setting is saved in `options.bin` under the user folder, for example, in `C:\Users\\AppData\Local\Trimble\Tekla Structures\\UserSettings`. Restart Tekla Structures to activate the new value.

4.28 XS_CLASH_CHECK_BETWEEN_REINFORCING_BARS

Category

Modeling Properties

Set this advanced option to `TRUE` to detect clashes between Tekla Structures reinforcing bars, and between reinforcing bars and other Tekla Structures objects (steel parts, bolts, embeds, and reference objects). Set to `FALSE` to detect clashes between reinforcing bars and other Tekla Structures objects except between reinforcing bars. The default is `TRUE`.

This advanced option is model specific and the setting is saved in the options database.

4.29 XS_CLEAR_MODEL_HISTORY

Category

Speed and Accuracy

If you use model history log files, set this advanced option to `TRUE` to clear history data from the log file each time you open and save the model. The default value is `FALSE`.

This advanced option is system specific and is read from environment files. Generally, there is no need to modify system-specific settings. Do not modify them if you are not an administrator.

See also

[XS_COLLECT_MODEL_HISTORY](#) (page 98)

4.30 XS_CLONING_TEMPLATE_DIRECTORY

Category: File locations

Enter a path to the folder that contains cloning template models used by the **Master Drawing Catalog**. You can have several paths separated by semicolon. This advanced option is set to `%XSDATADIR%\environments\common\cloning_templates` by default.

This advanced option is user specific and the setting is saved in `options.bin` under the user folder, for example, in `C:\Users\\AppData\Local\Trimble\Tekla Structures\\UserSettings`. Restart Tekla Structures to activate the new value.

4.31 XS_CLOUD_SHARING_PROXY

NOTE We recommend you to set this advanced option in **File menu --> Sharing --> Sharing settings --> Tekla Model Sharing cache**.

Use this advanced option to set up a cache server that is used with the Tekla Model Sharing sharing service.

If needed, the advanced option can be set in initialization files. Set `XS_CLOUD_SHARING_PROXY` to name of the server;port in initialization files.

This advanced option is user-specific.

4.32 XS_CNC_CUT_PLANE_HEIGHT

Category

CNC

Set this advanced option to a value between 0.3 and 1.0 if you get the following warning in the `dstv_nc.log` file for some NC files:

```
Error: Can't find intersection between solid and nc plane.  
Please try to adjust XS_CNC_CUT_PLANE_HEIGHT (0.3 .. 1.0)
```

You may get these warnings when you try to create NC files for folded parts. These NC files are not correct. For example, the external contours of the part may be entirely missing from the NC file. You will notice this, if you view a DXF file created from the NC file.

To use this advanced option, follow these steps:

1. Set this advanced option using a value bigger than 0.3. Start with smaller values first. The internal default value is 0.3.
2. Create the NC files for the problematic part.
3. Check the file `dstv_nc.log`, and if there is still warning for this part, repeat steps 1 to 4 with another value.
4. After creating the NC files without any error messages in the `dstv_nc.log`, remove the advanced option from the `user.ini` file as this advanced option may cause problems for some other parts.

This advanced option is model specific and the setting is saved in the options database.

4.33 XS_CNC_HOLE_DIAMETER_ROUNDING

Category: CNC

Defines the rounding factor of holes for NC files. NC files are accurate to 0.01 mm. Note that tapped holes are also affected.

Use to round bolt diameters with very small differences in diameter to the same value. You may need to use different diameters because bolts can have different tolerance values in a Tekla Structures model. You can input more decimals into bolt tolerance values in the component dialog boxes than in the general bolt dialog box.

The rounding routine is used only when you create NC files.

Set the rounding factor the same value (in mm) as the drill tolerance of the machine tool. The default value is 0.00001.

Tekla Structures divides the original hole diameter by the rounding factor, then rounds the result to the nearest integer, then multiplies it by the rounding factor. As a result, bolt diameters with very small differences in diameter are now rounded to the same value.

This advanced option is model specific and the setting is saved in the options database.

Example

Here the rounding factor is 1.5875 (1/16 inch), which results in the following:

- Diameter 26.99 mm (1" 1/16 from component dialog box) => 26.99/1.5875 => 17.00 => 17 => 17*1.5875 => 26.99 mm
- Diameter 27.00 mm (1" 1/16 from bolt dialog box) => 27.00/1.5875 => 17.01 => 17 => 17*1.5875 => 26.99 mm

4.34 XS_COLLECT_MODEL_HISTORY

Category

Speed and Accuracy

Tekla Structures is able to collect model history data on various objects, for example, parts in the inquire object dialog, reinforcing bars, and components in reports, etc. Set this advanced option to `TRUE` (default) to collect the data. If you do not want to collect the model history, set it to `FALSE`.

This advanced option is model specific and the setting is saved in the options database.

See also

[XS_CLEAR_MODEL_HISTORY \(page 95\)](#)

4.35 XS_COMBINED_BOLT_DIM_CHARACTER

Category

Dimensioning: Bolts

Use to set the character in bolt dimensions. The default value is asterisk (*).

This advanced option is model specific and the setting is saved in the options database.

4.36 XS_COMPANY_SETTINGS_DIRECTORY

Category

This advanced option must be set in an initialization (.ini) file.

Use this advanced option to define a folder where the initialization file `company.ini` is located. This file contains enterprise-level settings. You can define the folder, for example, in an `options.ini` file located under the model, firm or project folder.

4.37 XS_COMPLEX_PART_MEMBERS_DO_NOT_HAVE_TO_BE_MAIN_PARTS

Category

Dimensioning: Parts

Use in complex part/ assembly dimensioning to have Tekla Structures dimension other than main parts as one. The default value is `FALSE`.

This advanced option is role specific. When the type **SYSTEM(ROLE)** is in use, the default value is used. When the type **MODEL(ROLE)** or **DRAWING(ROLE)** is in use, you can change the value, which is then the same for all users in the current model.

4.38 XS_COMPONENT_CATALOG_ALLOW_SYSTEM_EDIT

Category: Modeling Properties

Set this advanced option to `TRUE` to be able to edit the **Applications & components** catalog definition files that are located in the `XS_SYSTEM` folders.

Generally, there is no need to modify system-specific settings. Do not modify them if you are not an administrator.

4.39 XS_COMPONENT_CATALOG_DO_REPORT_LEGACY_FILE_ISSUES

Category

This advanced option must be set in an initialization (.ini) file.

This advanced option is system specific and is read from `teklastructures.ini`. Generally, there is no need to modify system-specific settings. Do not modify them if you are not an administrator.

Set the advanced option to `TRUE` to enable the reporting of legacy component catalog issues to the message log in the **Applications and Components** catalog.

Restart Tekla Structures after changing the value to activate the new setting.

4.40 **XS_COMPONENT_CATALOG_COMPACT_THUMBNAI_SIZE**

Category: Modeling Properties

Use to adjust the size of thumbnails to between 16 and 96 pixels in the compact view. The default is 40.

This advanced option is user specific and the setting is saved in `options.bin` under the user folder, for example, in `C:\Users\<user>\AppData\Local\Trimble\Tekla Structures\<version>\UserSettings`. Restart Tekla Structures to activate the new value.

See also

[XS_COMPONENT_CATALOG_THUMBNAI_SIZE \(page 100\)](#)

4.41 **XS_COMPONENT_CATALOG_THUMBNAI_SIZE**

Category: Modeling Properties

Use to adjust the size of thumbnails to between 16 and 96 pixels in the normal view. The default is 96 pixels.

This advanced option is user specific and the setting is saved in `options.bin` under the user folder, for example, in `C:\Users\<user>\AppData\Local\Trimble\Tekla Structures\<version>\UserSettings`. Restart Tekla Structures to activate the new value.

See also

[XS_COMPONENT_CATALOG_COMPACT_THUMBNAI_SIZE \(page 100\)](#)

4.42 XS_CONCRETE_PART_NUMBERING_PREFIX

Category

Numbering

Use to define a numbering prefix for concrete parts. The default value is `Concrete`.

This advanced option is model specific and the setting is saved in the options database.

See also

[XS_CONCRETE_PART_NUMBERING_START_NUMBER \(page 101\)](#)

4.43 XS_CONCRETE_PART_NUMBERING_START_NUMBER

Category

Numbering

Use to define a start number for concrete parts. The default value is 1.

This advanced option is model specific and the setting is saved in the options database.

See also

[XS_CONCRETE_PART_NUMBERING_PREFIX \(page 100\)](#)

4.44 XS_CONNECTING_SIDE_MARK_SYMBOL

Category: Marking - parts

Use to change the symbol for a connecting side mark in single-part, cast unit, and assembly drawings. By default, the side mark symbol is symbol number 34 in the `xsteel.sym` symbol file. To change the symbol, set this advanced option to a different symbol number.

In general arrangement drawings, use [XS_GA_CONNECTING_SIDE_MARK_SYMBOL \(page 242\)](#).

This advanced option is model specific and the setting is saved in the options database.

4.45 XS_CONNECT_CONNECTION_PARTS_IN_AUTOCONNECTION

Category: Components

Set this advanced option to `FALSE` (default) if you do not want to connect the parts created by the connection in Autoconnection. If you set it to `TRUE`, the parts created by the connection are connected in Autoconnection.

This advanced option is model specific and the setting is saved in the options database.

See also

4.46 XS_CONNECT_PLATE_PROFILES_IN_AUTOCONNECTION

Category

Components

Set to `TRUE` to enable **AutoConnection** for built-up members. If you set this advanced option to `FALSE`, Tekla Structures does not consider plates as members when you use AutoConnection. The default value is `TRUE`.

This advanced option is model specific and the setting is saved in the options database.

4.47 XS_CONNECT_UPLOAD_MODEL_FOLDER

Category: File locations

Use this advanced option to define a Trimble Connect project folder where the current Tekla Structures model is uploaded as a read-only `.tekla` reference model. The `.tekla` reference model works as the counterpart of the Tekla Structures model in the linked Trimble Connect project. Uploading the Tekla Structures model as a `.tekla` reference model allows you to use Todos and other Trimble Connect commands with the model.

Enter a path to the folder in the attached Trimble Connect project into which you want upload the current Tekla Structures model. By default, the folder path is `Structural\Tekla models`.

If you are working with a model that has been shared with Tekla Model Sharing, use the [\(page 465\)](#) advanced option to define when the shared model will be uploaded to the Trimble Connect project folder.

This advanced option is model specific and the setting is saved in the options database.

4.48 XS_CONSIDER_NEIGHBOUR_PARTS_IN_HIDDEN

Category

Drawing Properties

Set this advanced option to `TRUE` (default) to draw parts behind neighbor using hidden lines. If you want to show parts behind neighboring parts using a visible line type, set this advanced option to `FALSE`.

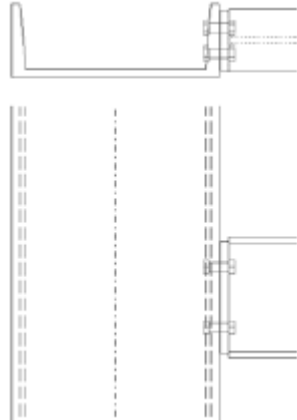
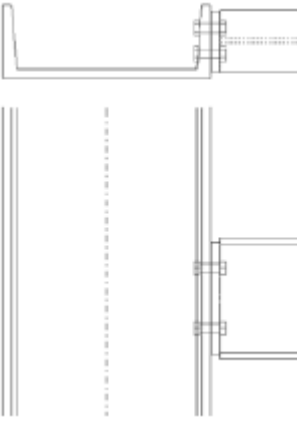
| Setting | Example of appearance in drawing |
|---|---|
| Set to <code>TRUE</code> (default). Parts behind neighbor parts are drawn with hidden lines. |  <p>The drawing shows a vertical assembly with a horizontal part extending to the right. The part behind the neighbor is represented by dashed lines, indicating it is hidden.</p> |
| Set to <code>FALSE</code> . Parts behind neighbor parts are drawn with the visible line type. |  <p>The drawing shows the same vertical assembly. In this case, the part behind the neighbor is drawn with solid lines, indicating it is visible.</p> |

This advanced option is model specific and the setting is saved in the options database.

4.49 XS_CONSIDER_REBAR_HOOK_LOCATION_IN_CAST_UNIT_NUMBERING

This advanced option must be set in an initialization (.ini) file.

Use this advanced option to define whether the location of the reinforcing bar hooks is taken into account in cast unit numbering or not.

The default value is `TRUE` in the `common` environment.

When this advanced option is set to `TRUE`, cast units that are otherwise identical will receive different numbers if the hooks in otherwise identical bars point in different directions, or if the stirrup hooks are in different corners, for example.

Restart Tekla Structures after changing the value to activate the new setting.

4.50 XS_CONSIDER_REBAR_NAME_IN_NUMBERING

Category

Concrete Detailing

Set to `FALSE` to have Tekla Structures only take part names into account when numbering, not reinforcing bar names. The default value is `FALSE`.

This advanced option is model specific and the setting is saved in the options database.

4.51 XS_CONTOUR_PLATE_POINT_ON_SAME_LINE_LIMIT

Category

Modeling Properties

Cleans away system component provided contour plate profile points in cases where points are on an almost straight line if the provided (middle) points deviate from the line at most as much as the value of this advanced option.

The point is then so close to the line between the previous and next point that it is redundant and can be removed. Enter a decimal value. The default is 1.0 mm.

This advanced option is model specific and the setting is saved in the options database.

See also

[XS_CONTOUR_PLATE_POINT_ON_SAME_LINE_LIMIT_FOR_CLOSE_POINTS \(page 105\)](#)

4.52 XS_CONTOUR_PLATE_POINT_ON_SAME_LINE_LIMIT_FOR_CLOSE_POINTS

Category

Modeling Properties

Cleans away system component provided contour plate profile points in cases where points are on an almost straight line if the provided (middle) points deviate from the line at most as much as the value of this advanced option. The point is then so close to the line between the previous and next point that it is redundant and can be removed. This advanced option is used if section point distances between two consecutive points are smaller than 10.0 mm. The default value for this advanced option is 0.1 mm.

This advanced option is model specific and the setting is saved in the options database.

See also

[XS_CONTOUR_PLATE_POINT_ON_SAME_LINE_LIMIT \(page 104\)](#)

4.53 XS_CONVERSION_ARBITRARY_PROFILE_MAPPING_BY_NAME_MUST_MATCH_DIMENSIONS

Category: Modeling properties

Set this advanced option to `TRUE` to require that the dimensions match the arbitrary profile mapping when mapping profile name to profile name in IFC object conversion. `FALSE` is the default value.

This advanced option is model specific and the setting is saved in the options database.

4.54 XS_CONVERT_OLD_FORCE_UNITS_TO_SI_FROM

Category

Components

Use to define how to convert part and connection attribute tables when you open a Tekla Structures catalog prior to version 7.0.

You can use the following units: kg/T/N/daN/kN/lbf/kip, or a numerical value.

This advanced option is model specific and the setting is saved in the options database.

Example

To convert force units from kip to SI, set this advanced option to `kip`.

4.55 XS_CONVERT_OLD_MOMENT_UNITS_TO_SI_FROM

Category

This advanced option must be set in an initialization (.ini) file.

Use to define how to convert part and connection attribute tables when you open a Tekla Structures catalog prior to version 7.0.

You can use the following units: kgm/Tm/Nm/daNm/kNm/lbf-in/lbf-ft/kip-in/kip-ft, or a numerical value.

Example

To convert moment units from kip-ft to SI, set this advanced option to `kip-ft`.

4.56 XS_COPY_REVISIONS_IN_AUTOMATIC_CLONING

Category

Drawing Properties

Set the advanced option `XS_COPY_REVISIONS_IN_AUTOMATIC_CLONING` to `TRUE` to copy the revisions and user-defined attributes to the automatically cloned drawings. `TRUE` is the default value.

This advanced option is model specific and the setting is saved in the options database.

4.57 XS_COUNT_ALL_PARTS_IN_NSFS_REPEATED_PART_MARK

Category

Marking: Parts

Use this advanced option to determine how the quantity of parts with merged part marks is shown. Set this advanced option to `TRUE` to count all parts. By default, this advanced option is set to `FALSE`.

This advanced option is role specific. When the type **SYSTEM(ROLE)** is in use, the default value is used. When the type **MODEL(ROLE)** or **DRAWING(ROLE)** is in use, you can change the value, which is then the same for all users in the current model.

Example

When there are four or more identical stiffeners on both sides of a beam web, the mark is

- 4x1002BS if `XS_COUNT_ALL_PARTS_IN_NSFS_REPEATED_PART_MARK` is set to `TRUE`.
- 2x1002BS if `XS_COUNT_ALL_PARTS_IN_NSFS_REPEATED_PART_MARK` is set to `FALSE`.

See also

[XS_COUNT_BOTH_PARTS_IN_NSFS_PART_MARK](#) (page 107)

4.58 XS_COUNT_BOTH_PARTS_IN_NSFS_PART_MARK

Category

Marking: Parts

Use this advanced option to determine how the quantity of parts with merged part marks is shown. Set this advanced option to `TRUE` to count both parts. If you do not want to do this, set it to `FALSE` (default).

This advanced option is role specific. When the type **SYSTEM(ROLE)** is in use, the default value is used. When the type **MODEL(ROLE)** or **DRAWING(ROLE)** is in use, you can change the value, which is then the same for all users in the current model.

Example

When there are two identical stiffeners on both sides of a beam web, the mark is

- **2x1002BS** if `XS_COUNT_BOTH_PARTS_IN_NSFS_PART_MARK=TRUE`.

- **1002BS** if `XS_COUNT_BOTH_PARTS_IN_NSFS_PART_MARK=FALSE`.

See also

[XS_COUNT_ALL_PARTS_IN_NSFS_REPEATED_PART_MARK \(page 106\)](#)

4.59 XS_CREATE_ALSO_BIG_HTML_REPORT_PICTURES

Category

Concrete Detailing

Set to `TRUE` to create an additional set of pictures to the report folder. The pictures are three times larger in size compared to the ones in the HTML report. The default is `FALSE`.

This advanced option is user specific and the setting is saved in `options.bin` under the user folder, for example, in `C:\Users\\AppData\Local\Trimble\Tekla Structures\\UserSettings`. Restart Tekla Structures to activate the new value.

4.60 XS_CREATE_DRAWING_PREVIEW_AUTOMATICALLY

Category

Drawing Properties

Set this advanced option to `TRUE` to take a snapshot of a drawing each time the drawing is saved. The snapshot is saved in the `\drawing` folder under the current model folder. The snapshot is used as the default preview image for the drawing in the **Master Drawing Catalog**. If you set this advanced option to `FALSE`, the snapshot is not taken. The default value is `FALSE`.

This advanced option is user specific and the setting is saved in `options.bin` under the user folder, for example, in `C:\Users\\AppData\Local\Trimble\Tekla Structures\\UserSettings`. Restart Tekla Structures to activate the new value.

4.61 XS_CREATE_MISSING_MARKS_IN_INTELLIGENT_CLONING

Category: Marking - general

Use to create all marks to a cloned drawing where new parts have been added.

To create the marks, set the advanced option to `TRUE`. The default is `FALSE`.
 This advanced option is model specific and the setting is saved in the options database.

4.62 XS_CREATE_ROUND_HOLE_DIMENSIONS

Category

Dimensioning: Parts

Enter `TRUE` (default) to dimension the round hole center point in drawings.

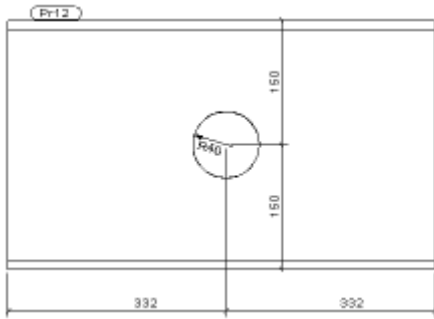
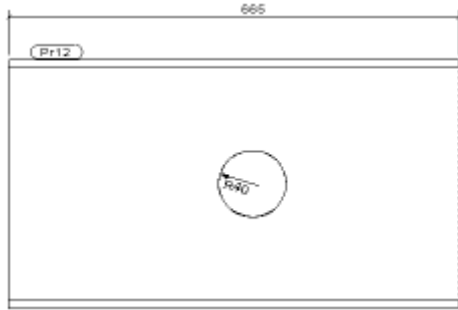
| Setting | Example of appearance in drawings |
|---------|--|
| TRUE |  |
| FALSE |  |

You get the automatic dimension to hole center only if the cut part profile is round.

This advanced option does not apply to automatic general arrangement drawing dimensions.

This advanced option is model specific and the setting is saved in the options database.

4.63 XS_CREATE_CONNECTION_WHEN_COPYING_DRAWING_VIEWS

Category

Drawing Properties

Set to `TRUE` to link copied views to the original drawing. This means, for example, that when you delete a drawing from which you copied a view, Tekla Structures also deletes the copied view. The default value is `FALSE`.

This advanced option is role specific. When the type **SYSTEM(ROLE)** is in use, the default value is used. When the type **MODEL(ROLE)** or **DRAWING(ROLE)** is in use, you can change the value, which is then the same for all users in the current model.

Useful links

For more information about using

`XS_CREATE_CONNECTION_WHEN_COPYING_DRAWING_VIEWS`, see the following Support Article in Tekla User Assistance: [What does the XS_CREATE_CONNECTION_WHEN_COPYING_DRAWING_VIEWS advanced option do?](#)

4.64 XS_DRAWING_CREATE_SNAPSHOT_ON_DRAWING_CREATION

Category: Drawing properties

Set this advanced option to `TRUE` to create a snapshot of a drawing at the same time that you create the drawing. If you set this option to `TRUE`, you no longer need to open a drawing to save it to create the snapshot. The default values is `FALSE`.

This advanced option is model specific and the setting is saved in the options database.

4.65 XS_CREATE_VIEW_FROM_MODEL_OLD_WAY

Category

Drawing View

Use this advanced option to specify which values Tekla Structures uses for drawing view boundaries in general arrangement drawings. This only affects views created from the model.

If you set this advanced option to `FALSE` (default), the drawing view boundaries values are based on the current work area x and y coordinates of a model view.

When this advanced option is set to `TRUE`, the drawing view boundary values are based on the entire model view, ignoring the work area settings.

In both cases depth values are based on the model view display depth values.

This advanced option is model specific and the setting is saved in the options database.

4.66 XS_CS_CHAMFER_DIVIDE_ANGLE

Category: Speed and accuracy

Use this advanced option to change the angles dividing a cross section chamfer. The default value is `30.0` degrees.

NOTE A very small value will cause profile roundings not to be visible.

Using this advanced option affects the rounding radius for parts that have high accuracy (for example parts in drawings and in DWG export).

This advanced option is model specific and the setting is saved in the options database.

Example

`XS_CS_CHAMFER_DIVIDE_ANGLE=10.0`

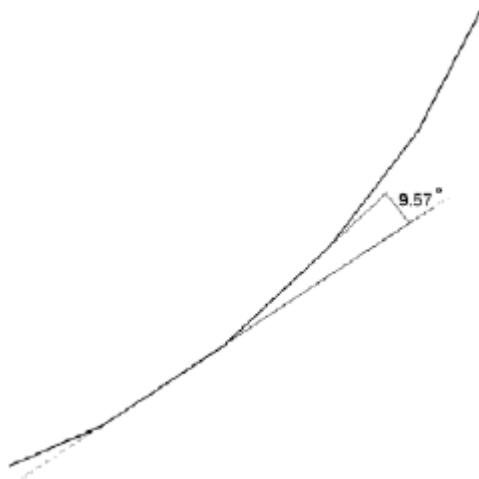

TIP When you want to export B-rep as exact solids in the IFC export, you need to set the advanced option [XS_EXPORT_BREP_AS_EXACT_SOLID](#)

(page 229) to TRUE. To get smoother edges to the export, set XS_CS_CHAMFER_DIVIDE_ANGLE to 10.

See also

[XS_SOLID_USE_HIGHER_ACCURACY \(page 444\)](#)

4.67 XS_CURVED_AXIS_PLACE

Category

Profiles

By default, Tekla Structures calculates the length of curved parts along the center axis. Use this advanced option to define the position of this axis as a ratio.

Tekla Structures calculates the location of the axis using the formula $h=H/2.0*ratio$. The default value is zero (0). Define the ratio as 1.0 to calculate length along the upper flange. Define the ratio as -1.0 to define the length along the lower flange.

This value is used in reports and drawing templates.

4.68 XS_CUSTOM_COMPONENT_DECIMALS

Category

Speed and Accuracy

Use this advanced option to adjust the number of decimals for custom components. This setting only works with parametric variables whose **Value type** is **Text**. Other parameter types follow the normal accuracy settings.

The default value is 3.

4.69 XS_CUT_SYMBOL_FONT

Category

Drawing Properties

Use to define the font for section symbol text. The default value is Arial. If you do not specify a font, Tekla Structures uses the default font defined for `XS_DEFAULT_FONT`.

This advanced option is model specific and the setting is saved in the options database.

See also

[XS_DEFAULT_FONT \(page 116\)](#)

4.70 XS_CYCLIC_SOLVER_MAX_LOOPS

Category

Modeling properties

Use to define how many cycles Tekla Structures makes to solve the dependencies in custom components. Enter a number for the amount of cycle loops. The default is 2.

This advanced option is model specific and the setting is saved in the options database.

5 Advanced options - D

5.1 DAK_BMPPATH

This advanced option must be set in an initialization (.ini) file.

This advanced option is system specific and is read from `teklastructures.ini`. Generally, there is no need to modify system-specific settings. Do not modify them if you are not an administrator.

Use to point to the folder for bitmap files used in

- custom components
- user-defined attributes (`objects.inp` file)
- profile catalog
- some system components

You can use semicolon-separated lists of folder paths, see an example below. This advanced option is by default defined in the `teklastructures.ini` file and it points to the folder `..\ProgramData\Trimble\Tekla Structures \<version>\Bitmaps`

Example

```
DAK_BMPPATH=%XSDATADIR%\Bitmaps\  
DAK_BMPPATH=%XSDATADIR%\Bitmaps\;H:\Tekla\bitmap\
```

5.2 XSDATADIR

Category

This advanced option must be set in an initialization (.ini) file.

This advanced option is system specific and is read from `teklastructures.ini`. It can also be set locally, see your environment `.ini` file (`env_<environment_name>.ini`). Generally, there is no need to modify system-specific settings. Do not modify them if you are not an administrator.

`XSDATADIR` is defined in the `teklastructures.ini` file. It points to a location where the installation installs the environment files and folders.

Example

By default, this advanced option is set as follows: `set XSDATADIR=C:\ProgramData\Trimble\Tekla Structures\<version>\`

5.3 XS_DEFAULT_BREP_PATH

This advanced option must be set in an initialization (.ini) file.

Use to define the location of the default shapes that are available in the shape catalog when you create a new model. By default, this advanced option is set to point to the `common` environment, and the definition files of the default shapes are read from the `\Shapes` and `\ShapeGeometries` folders under the `\profil` folder.

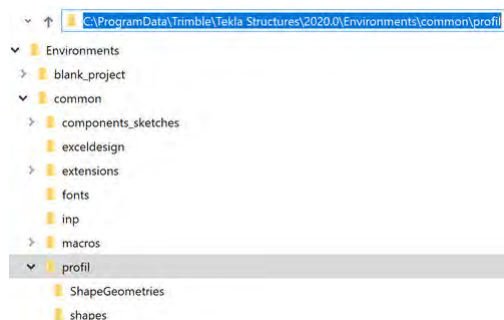

The definition files of the shapes that you use from this location when you create items in a model are copied to the model folder.

Example

To have Tekla Structures read the default shapes from the German environment, set this advanced option as follows:

```
set XS_DEFAULT_BREP_PATH=%XSDATADIR%\environments\germany\  
or
```

```
set XS_DEFAULT_BREP_PATH=C:\ProgramData\Trimble\Tekla  
Structures\<version>\environments\germany\  
or
```

5.4 XS_DEFAULT_ENVIRONMENT

This advanced option must be set in an initialization (.ini) file.

Use together with [XS_DEFAULT_LICENSE \(page 118\)](#) and [XS_DEFAULT_ROLE \(page 119\)](#) for bypassing the login dialog. Set these advanced options in a separate initialization file, and point to that file using the -l (capital i) parameter in the Tekla Structures shortcut. The parameter is used to point to a file which needs to be read **before** other initialization files.

WARNING If roles are used in your environment, both `XS_DEFAULT_ENVIRONMENT` and `XS_DEFAULT_ROLE` should be set for the startup to work correctly. `XS_DEFAULT_LICENSE` is optional.

Example

```
set XS_DEFAULT_ENVIRONMENT=C:\ProgramData\Trimble\Tekla Structures\<version>\Environments\germany\env_Germany.ini
```

5.5 XS_DEFAULT_FONT

Category: Model view

Use to specify the default font in the model and drawings, for example, when creating grids, dimensions, and mark texts. Enter the name of any Windows font, for example, Arial Narrow. The default value is Segoe UI semibold.

If any of the following advanced options are not set, or if font conversion is needed in drawings, Tekla Structures uses `XS_DEFAULT_FONT`:

- `XS_CUT_SYMBOL_FONT`
- `XS_DIMENSION_FONT`
- `XS_GRID_TEXT_FONT`
- `XS_MARK_FONT`
- `XS_VIEW_TITLE_FONT`
- `XS_WELD_FONT`

For example, if `XS_MARK_FONT` has no value set and you open an old model with a newer version of Tekla Structures, `XS_DEFAULT_FONT` is used when converting marks to the new model database.

This advanced option is user specific and the setting is saved in `options.bin` under the user folder, for example, in `C:\Users\<user>\AppData\Local`

\Trimble\Tekla Structures\\UserSettings. Restart Tekla Structures to activate the new value.

See also

[XS_DEFAULT_FONT_SIZE](#) (page 117)

[XS_CUT_SYMBOL_FONT](#) (page 112)

[XS_DIMENSION_FONT](#) (page 130)

[XS_GRID_TEXT_FONT](#) (page 247)

[XS_MARK_FONT](#) (page 289)

[XS_VIEW_TITLE_FONT](#) (page 507)

[XS_WELD_FONT](#) (page 511)

5.6 XS_DEFAULT_FONT_SIZE

Category

Model View

Use to set the default font size when modeling. The default value is 12.

This advanced option is user specific and the setting is saved in `options.bin` under the user folder, for example, in `C:\Users\\AppData\Local\Trimble\Tekla Structures\\UserSettings`. Restart Tekla Structures to activate the new value.

5.7 XS_DEFAULT_HEIGHT_FOR_CALCULATED_DRAWING_SIZE

Category: Drawing properties

Use to change the default height for the calculated drawing size. Enter the value in millimeters. The default value is 287.

This advanced option is model specific and the setting is saved in the options database.

5.8 XS_DEFAULT_KEEP_ONLINE_LICENSE_CHECKBOX

Use this advanced option to set the default value of the **Keep this license reserved on this device** check box in the closing confirmation message box.

This advanced option must be set in an initialization (.ini) file. For example, you can set this advanced option in `teklastructures.ini`, `options.ini`, or `bypass.ini`.

When this advanced option is set to `TRUE`, the **Keep this license reserved on this device** check box is selected, which keeps the subscription license seat reserved. The default value is `TRUE`.

When this advanced option is set to `FALSE`, the **Keep this license reserved on this device** check box is never selected by default.

When this advanced option is not set, the check box is selected if you selected it in the previous Tekla Structures session.

NOTE After you change the value of this advanced option, the user must sign out and sign in again for the change to take effect.

5.9 XS_DEFAULT_LICENSE

This advanced option must be set in an initialization (.ini) file.

Use to set the default subscription or license for a user role. The advanced option can be used either in a role-specific initialization file (`role_*.ini`) for setting the default license for a selected role, or in a separate initialization file together with [XS_DEFAULT_ROLE](#) (page 119) and [XS_DEFAULT_ENVIRONMENT](#) (page 116) for bypassing the sign in dialog.

WARNING If roles are used in your environment, both `XS_DEFAULT_ENVIRONMENT` and `XS_DEFAULT_ROLE` should be set for the startup to work correctly. `XS_DEFAULT_LICENSE` must be set if there are more than one license type available.

Possible values are:

- `CARBON`
- `GRAPHITE`
- `DIAMOND`
- `FULL`
- `TeklaStructures_Primary`
- `STEEL_DETAILING`
- `REBAR_DETAILING`
- `PRECAST_CONCRETE_DETAILING`
- `CONSTRUCTION_MODELING`

- DRAFTER
- ENGINEERING
- PROJECT_VIEWER
- PRODUCTION_PLANNER
- EDUCATIONAL
- DEVELOPER

See also

[XS_DEFAULT_ROLE \(page 119\)](#)

[XS_DEFAULT_ENVIRONMENT \(page 116\)](#)

5.10 XS_DEFAULT_MODEL_TEMPLATE

Category

This advanced option must be set in an initialization (.ini) file.

Use to define the model template which is used as the default in **File menu** --> **New** when you create a new model.

Define a value for the advanced option in the role initialization files, available in your environment folders. Store the default model template to the folder defined by the advanced option [XS_MODEL_TEMPLATE_DIRECTORY \(page 308\)](#).

If this advanced option is not set, the model template that was used last is displayed in **File menu** --> **New**.

Example

```
set XS_DEFAULT_MODEL_TEMPLATE=EngineeringTemplate
```

5.11 XS_DEFAULT_ROLE

This advanced option must be set in an initialization (.ini) file.

Use together with [XS_DEFAULT_LICENSE \(page 118\)](#) and [XS_DEFAULT_ENVIRONMENT \(page 116\)](#) for bypassing the login dialog. Set these advanced options in a separate initialization file, and point to that file using the -l (capital

i) parameter in the Tekla Structures shortcut. The parameter is used to point to a file which needs to be read **before** other initialization files.

WARNING If roles are used in your environment, both `XS_DEFAULT_ENVIRONMENT` and `XS_DEFAULT_ROLE` should be set for the startup to work correctly. `XS_DEFAULT_LICENSE` is optional.

Example

```
set XS_DEFAULT_ROLE=C:\ProgramData\Trimble\Tekla Structures
\<>version>\Environments\USA\Role_Imperial_Steel_Detailing.ini
```

5.12 XS_DEFAULT_UNICODE_FONT_DRAWING_PRINTING

Category Printing

Use this advanced option to define the default font that is used when the selected font for printing does not contain all of the multibyte characters used in the text. When a default font is defined, the characters are shown correctly even without embedding fonts. By default, the font is set to Arial Unicode MS. This font might not be installed on your machine by default, and you may need to install it. You can also define another font that contains the characters you need and that you have installed on your machine.

This advanced option is user specific and the setting is saved in `options.bin` under the user folder, for example, in `C:\Users\<user>\AppData\Local\Trimble\Tekla Structures\<version>\UserSettings`. Restart Tekla Structures to activate the new value.

5.13 XS_DEFAULT_WIDTH_FOR_CALCULATED_DRAWING_SIZE

Category: Drawing properties

Use to change the default width for the calculated drawing size. Enter the value in millimeters. The default is 410.

This advanced option is model specific and the setting is saved in the options database.

5.14 XS_DELETE_UNNECESSARY_DG_FILES

Category

Drawing Properties

Use the `XS_DELETE_UNNECESSARY_DG_FILES` advanced option to define if unnecessary drawing files are automatically deleted or not. To automatically delete the drawing files that are no longer used, set the advanced option to `TRUE` (default). If you do not want to delete the drawing files, set the advanced option to `FALSE`.

By default, the `.dg` files are deleted after 7 days. Use the `XS_DELETE_UNNECESSARY_DG_FILES_SAFETY_PERIOD` advanced option to define how long the drawing files are kept before they are deleted.

This advanced option is model specific and the setting is saved in the options database.

See also

[XS_DELETE_UNNECESSARY_DG_FILES_SAFETY_PERIOD \(page 121\)](#)

5.15 XS_DELETE_UNNECESSARY_DG_FILES_SAFETY_PERIOD

Category

Drawing Properties

Use the `XS_DELETE_UNNECESSARY_DG_FILES_SAFETY_PERIOD` advanced option to set the time frame after which unnecessary drawing files are deleted. Enter the required time frame in days. By default, `XS_DELETE_UNNECESSARY_DG_FILES_SAFETY_PERIOD` is set to 7 days.

WARNING We recommend that you do not modify the value of this advanced option unless you are an experienced Tekla Structures user.

This advanced option is model specific and the setting is saved in the options database.

See also

[XS_DELETE_UNNECESSARY_DG_FILES \(page 120\)](#)

5.16 XS_DELETE_UNNECESSARY_REFMODEL_FILES_SAFETY_PERIOD

Category : Multi-user

Defines the time frame after which unnecessary reference model files are deleted. Enter the required time frame in days. This advanced option is set to 7 days by default. This advanced option is used together with another advanced option `XS_REFERENCE_MODEL_KEEP_VERSIONS_COUNT`, which cleans up the unnecessary reference model revisions. Also have a look at the help article for [XS_REFERENCE_MODEL_KEEP_VERSIONS_COUNT](#) (page 376).

- In multiuser model, files are kept until the safety period has passed.
- Note that this advanced option has no effect on shared models. In shared model, files are kept until write out.

WARNING We recommend that you do not modify the value of this advanced option unless you are an experienced Tekla Structures user.

This advanced option is model specific and the setting is saved in the options database.

5.17 XS_DETAIL_BOUNDARY_RADIUS

Category

Drawing Properties

Use to define a fixed size for circle-shaped detail boundaries in detail views.

Enter a numeric value in millimeters for the radius. By default, no size is set.

This advanced option is model specific and the setting is saved in the options database.

5.18 XS_DETAIL_MARK_REFERENCE_SYMBOL

Category: Drawing properties

If you have set **Symbol** to **Custom** on the **Detail mark** tab of the **Detail symbol properties** dialog box, Tekla Structures uses the value that you have

set to this advanced option. For example, if you enter `xsteel@3`, Tekla Structures uses the symbol number 3 in symbol file `xsteel.sym`.

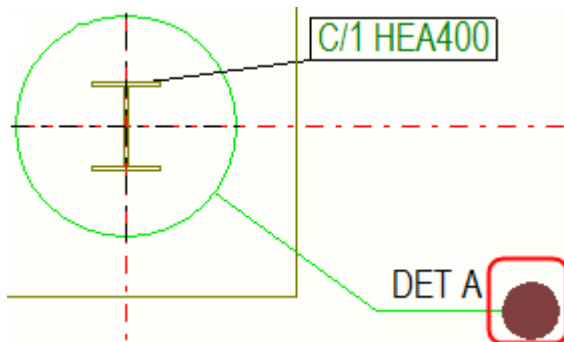

This advanced option is model specific and the setting is saved in the options database.

5.19 XS_DETAIL_SYMBOL_REFERENCE

Category: Drawing properties

You can move drawing views from one drawing to another. This advanced option sets the reference text for detail symbols for detail views moved to another drawing. You can enter free text, user-defined attributes (`%UDA_NAME%`, `%USERDEFINED.UDA_NAME%`), or template attributes (`%ATTRIBUTE_NAME%`).

If you enter user-defined attributes or template attributes, use single `%` characters around them in the **Advanced options** dialog box.

`%DRAWING_TITLE%` is the default value, and `%TITLE%` gives the same result. If you use these attributes, the detail symbol gets the drawing name entered in the **Name** field in the drawing properties dialog box. If you enter `%TITLE1%`, `%TITLE2%`, or `%TITLE3%`, the symbol gets the text from the **Title 1 - Title 3** fields in drawing properties. You can also use the format `%DR_TITLE1%`, `%DR_TITLE2%`, and `%DR_TITLE3%` to do the same.

| General arrangement drawing properties | |
|--|---|
| Save | Load |
| PCD_Ceiling_Plan | |
| %DRAWING_TITLE% | <input checked="" type="checkbox"/> Name: CEILING PLAN +3 000 |
| %TITLE1% | <input checked="" type="checkbox"/> Title 1: <input type="text"/> |
| %TITLE2% | <input checked="" type="checkbox"/> Title 2: <input type="text"/> |
| %TITLE3% | <input checked="" type="checkbox"/> Title 3: <input type="text"/> |

For more information about moving views to another drawing, see [Copy, link, or move drawing views](#).

This advanced option is model specific and the setting is saved in the options database.

See also

[XS_DETAIL_VIEW_REFERENCE](#) (page 124)

5.20 XS_DETAIL_VIEW_REFERENCE

Category: Drawing properties

You can move drawing views from one drawing to another. This advanced option sets the reference text for detail view labels for details moved to another drawing. You can enter free text, user-defined attributes (`%UDA_NAME%`, `%USERDEFINED.UDA_NAME%`), or template attributes (`%ATTRIBUTE_NAME%`).

If you enter user-defined attributes or template attributes, use single `%` characters around them in the **Advanced options** dialog box. The `%DRAWING_TITLE%` attribute is the default value, and the `%TITLE%` attribute gives the same result. If you use these attributes, the view label gets the drawing name entered in the **Name** field in the drawing properties dialog box. If you enter `%TITLE1%`, `%TITLE2%`, or `%TITLE3%`, the view label gets the text from the **Title 1 - Title 3** fields in drawing properties. You can also use the format `%DR_TITLE1%`, `%DR_TITLE2%`, and `%DR_TITLE3%` to do the same.

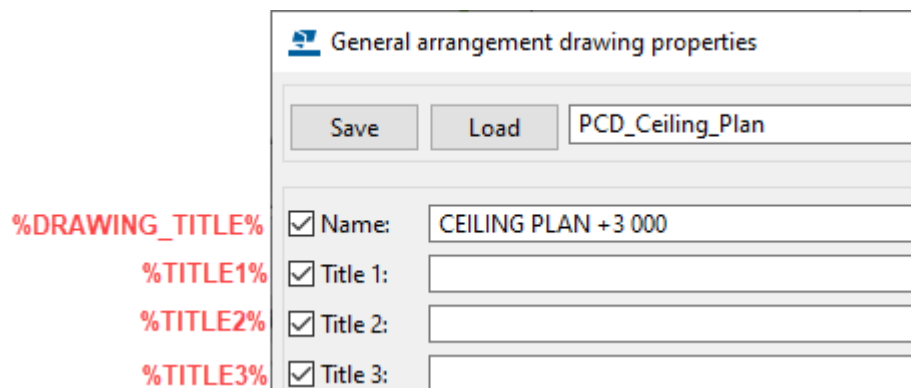

For more information about moving views to another drawing, see [Copy, link, or move drawing views](#).

This advanced option is model specific and the setting is saved in the options database.

See also

[XS_DETAIL_SYMBOL_REFERENCE](#) (page 123)

5.21 XS_DGN_EXPORT_PART_AS

Category

This advanced option must be set in an initialization (.ini) file.

Use to specify how Tekla Structures exports solid objects to DGN format.

- Set to `CELL` to export solid objects as cells containing the solid faces as a DGN shape.
- Set to `SOLID` to export solid objects as DGN solid objects defined by boundary elements.

The default value is `CELL`.

5.22 XS_DGN_EXPORT_USE_LOCAL_ID

Category

Export

Set this advanced option to `TRUE` to enable the use of local ID numbers in 3D DGN export. Every exported part gets a unique ID number starting from 1. The ID is saved as a user-defined attribute, and the same ID will be used in consequent exports. The default value is `TRUE`.

This advanced option is model specific and the setting is saved in the options database.

5.23 XS_DIAGNOZE_AND_REPAIR_WRONG_UDA_TYPE

Category: Speed and accuracy

Set this advanced option to `TRUE` to enable the detecting and fixing of the incorrect user-defined attribute (UDA) value types in **Diagnose & repair --> Diagnose and change attribute definitions**.

The default value is `TRUE`.

If you edit the `object.inp` file by changing the UDA value type after the values are set, the UDA values of the incorrect types are not reported correctly, and you cannot change them.

When `XS_DIAGNOZE_AND_REPAIR_WRONG_UDA_TYPE` is set to `TRUE`, use can use **Diagnose & repair --> Diagnose and change attribute definitions** to detect and repair the incorrect UDA value types by reverting the value types to the default values.

WARNING We recommend that you do not modify the value of this advanced option unless you are an experienced Tekla Structures user.

5.24 XS_DIALOG_ENABLE_STATE

This advanced option must be set in an initialization (.ini) file.

Use this advanced option to remove selections from dialog box check boxes. TRUE is the default value.

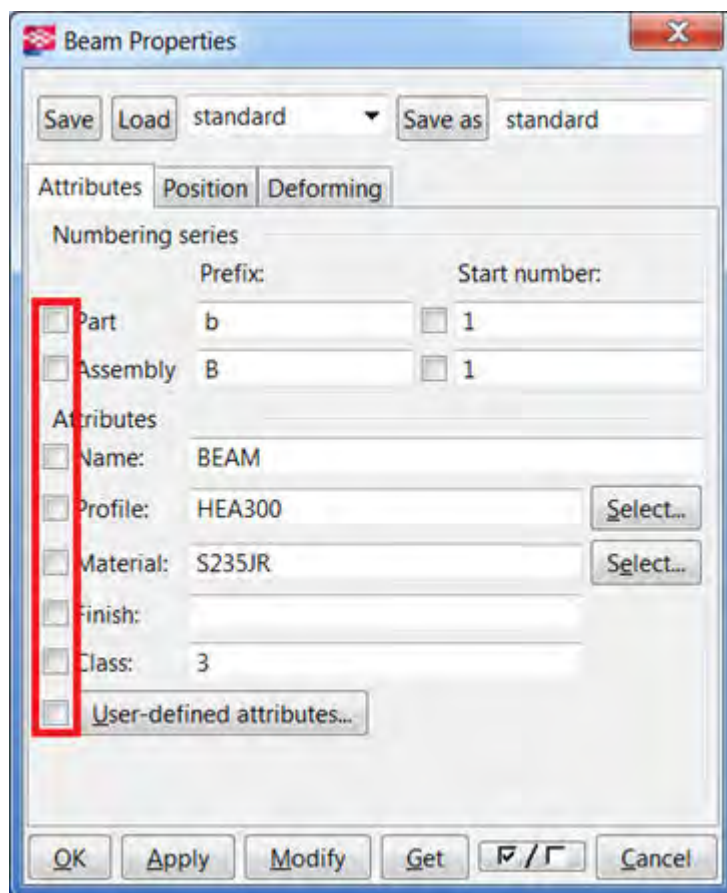

5.25 XS_DIMENSION_ALL_BOLT_GROUPS_SEPARATELY

Category

Dimensioning: Bolts

Set this advanced option to `TRUE` to prevent Tekla Structures from combining bolt group dimensions. To combine bolt group dimensions, set it to `FALSE` (default).

This advanced option is model specific and the setting is saved in the options database.

5.26 XS_DIMENSION_DECIMAL_SEPARATOR

Category: Dimensioning - general

Use to define the character to be used as a decimal separator in dimensions and level marks in drawings, templates and reports. The default value is a full stop (.).

`XS_DIMENSION_DECIMAL_SEPARATOR = <separator character>`.

This advanced option is model specific and the setting is saved in the options database.

NOTE With this advanced option, you can change the separators in dimension objects in drawings, templates and reports, but not in part marks.

Example

In the following example, the dimension mark contains a comma when the dimension settings in the **Dimension Properties** dialog box are as follows, and the advanced option is set to `XS_DIMENSION_DECIMAL_SEPARATOR=,`

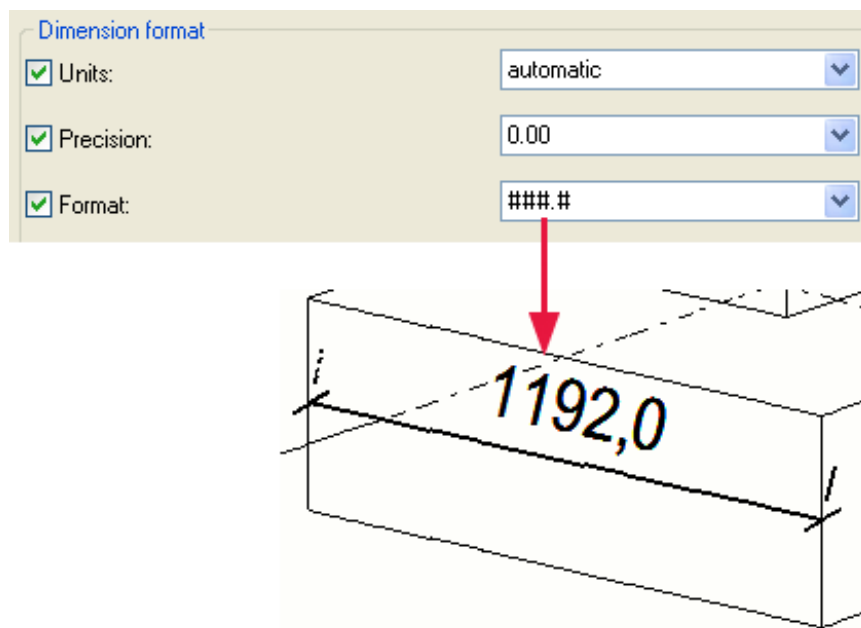

In the following example, the separator was first a period and was then changed to a comma.

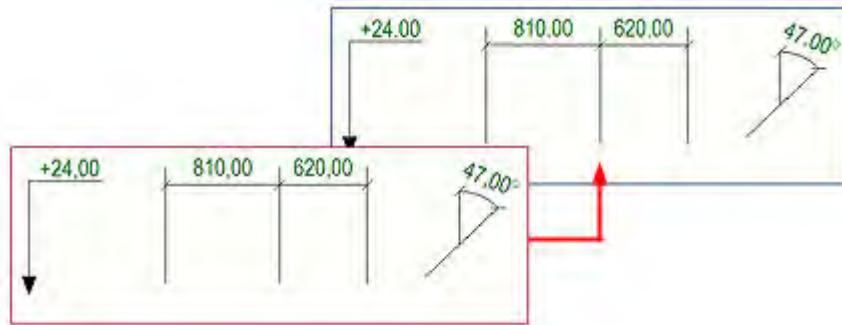

5.27 XS_DIMENSION_DIGIT_GROUPING_CHARACTER

Category: Dimensioning - general

Use to specify which separator character to use in large dimension values. For example, entering a comma (,) results in 154321 becoming 154,321. If you do not specify a character, Tekla Structures uses a space in dimensions when you set **Digit grouping** to **Yes** in **Dimension properties (Use grouping** in GA drawings). By default, no value is set.

This advanced option is model specific and the setting is saved in the options database.

See also

[XS_DIMENSION_DIGIT_GROUPING_COUNT](#) (page 128)

Dimension properties

5.28 XS_DIMENSION_DIGIT_GROUPING_COUNT

Category: Dimensioning - general

Use to specify the number of digits after which a space (default) or a [separator character](#) (page 128) will be inserted in dimension values. If you set this advanced option to 3 (default), 154321 becomes 154 321.

This advanced option is model specific and the setting is saved in the options database.

See also

[XS_DIMENSION_DIGIT_GROUPING_CHARACTER](#) (page 128)

Dimension properties

5.29 XS_DIMENSION_EXTENSION_LINE_AWAY_FACTOR

Category: Dimensioning - general

Use to adjust the length of the dimension extension lines that are facing away from the dimension points. Define the length as a factor for the dimension text size. The default is 1.0 (text height * 1.0).

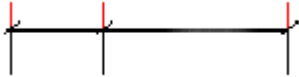

This option is used only when the option **Short extension line** is set to **Yes** or **On grid lines only** in the dimension properties.

This advanced option is model specific and the setting is saved in the options database.

See also

Modify dimensions

[XS_DIMENSION_EXTENSION_LINE_TOWARD_FACTOR](#) (page 129)

5.30 XS_DIMENSION_EXTENSION_LINE_ORIGIN_OFFSET

Category

Dimensioning: General

Use to specify the distance between the extension line origin and the start of the extension line (extension line origin offset). The default value is 1.

This advanced option is model specific and the setting is saved in the options database.

In the following example, extension line origin offset is defined:

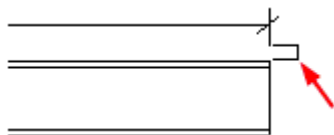

5.31 XS_DIMENSION_EXTENSION_LINE_TOWARD_FACTOR

Category: Dimensioning - general

Use to adjust the length of the dimension extension lines that are facing towards the dimension points. Define the length as a factor for the dimension text size. The default is 1.5 (text height * 1.5).

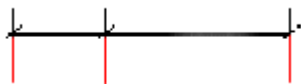

This option is used only when the option **Short extension line** is set to **Yes** or **On grid lines only** in the dimension properties.

This advanced option is model specific and the setting is saved in the options database.

See also

Modify dimensions

[XS_DIMENSION_EXTENSION_LINE_AWAY_FACTOR](#) (page 129)

5.32 XS_DIMENSION_FONT

Category

Drawing Properties

Use to specify the font for dimension text. The default value is Arial. If you do not specify a font, Tekla Structures uses the default font defined for XS_DEFAULT_FONT instead.

This advanced option is model specific and the setting is saved in the options database.

See also

[XS_DEFAULT_FONT](#) (page 116)

5.33 XS_DIMENSION_GROUPING_COUNT_SEPARATOR

Category: Dimensioning - general

Use to define the symbol that is displayed between the quantity and the automatic tag text in grouped dimensions. The default is x.

This advanced option is model specific and the setting is saved in the options database.

Note that the advanced option

`XS_DIMENSION_GROUPING_COUNT_SEPARATOR` is intended for grouped dimensions that are defined in the dimensioning settings for Integrated dimensioning. For other dimension marks, use the advanced option [XS_DIMENSION_MARK_MULTIPLIER](#) (page 132).

5.34 XS_DIMENSION_LINE_TEXT_EPS

This advanced option has been removed, please use the advanced option [XS_TEXT_ORIENTATION_EPSILON](#) (page 455) instead.

5.35 XS_DIMENSION_MARK_CONNECTOR

Category: Dimensioning - general

Use this advanced option to change the character that is used in dimension tags when the dimension tag displays the properties of the different objects dimensioned, for example, different part positions, and one dimension line is used. A plus sign is used by default.

This advanced option is model specific and the setting is saved in the options database.

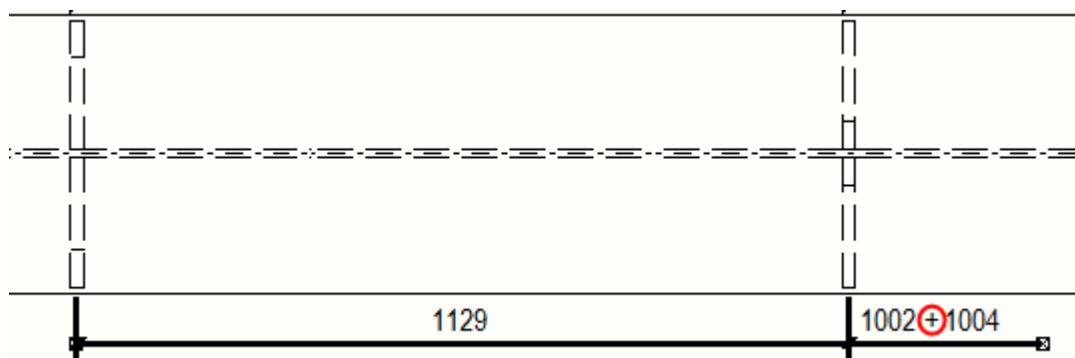

5.36 XS_DIMENSION_MARK_CREATE_MIDDLE_TAG_ALWAYS

This advanced option must be set in an initialization (.ini) file.

Since Tekla Structures version 2017, the dimension middle tag functionality has been extended to show by default object information also when the dimension start and end are pointing to different objects. In previous versions, the middle tag content was only shown when the start and end were pointing to the same object. The previous functionality can be taken into use by setting this advanced option to `FALSE`.

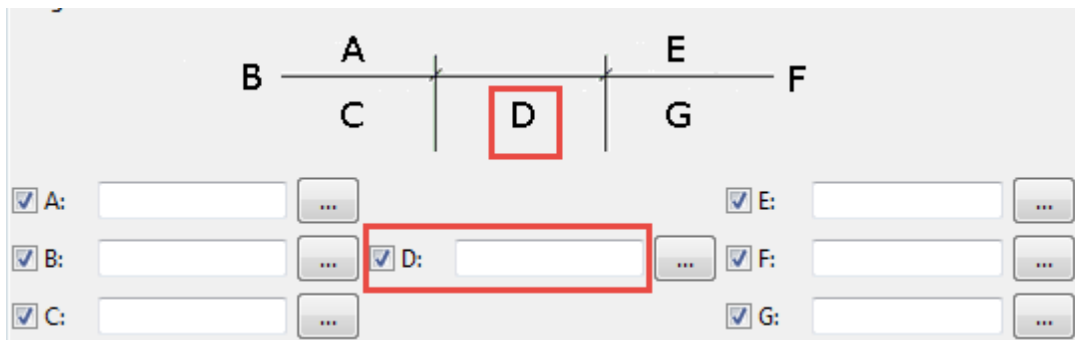

5.37 XS_DIMENSION_MARK_MULTIPLIER

Category

Dimensioning: General

Use this advanced option to change the multiplication sign when there are several parts that have the same mark content, for example, HEA400 + 2 **x** HEA300. This advanced option has effect only if you have selected **Include part count in tag** in the **Dimension Properties** dialog box. `x` is the default value.

This advanced option is model specific and the setting is saved in the options database.

5.38 XS_DIMENSION_PART_MARK_CONTENT_IN_ASSEMBLY

Category

Dimensioning: Parts

Use for defining the content of the part mark placed next to the dimension line label in assembly drawings. Give any combination of the switches.

The available switches are:

- PROFILE
- MATERIAL
- SIZE
- LENGTH
- COMMENT
- WPDIST (distance between work points)
- GR_L (gross length of the part)

TIP If you want to display the part mark content in the same order as the switches, set `XS_DIMENSION_PART_MARK_CONTENT_STRICT_POSITION` to TRUE.

This advanced option is role-specific. When you change the value, it changes from system- to model-specific, and its value is the same for all users in the current model.

Example

```
XS_DIMENSION_PART_MARK_CONTENT_IN_ASSEMBLY=PROFILE_AND_LENGTH
.
XS_DIMENSION_PART_MARK_CONTENT_IN_ASSEMBLY=PROFILE_AND_GR_L
```

See also

[XS_DIMENSION_PART_MARK_CONTENT_IN_SINGLE](#) (page 133)

[XS_DIMENSION_PART_MARK_CONTENT_STRICT_POSITION](#) (page 134)

5.39 XS_DIMENSION_PART_MARK_CONTENT_IN_SINGLE

Category

Dimensioning: Parts

Use to define the content of the part mark that is placed next to the dimension line label in single-part drawings. Give any combination of the switches.

The available switches are:

- PROFILE
- MATERIAL
- SIZE
- LENGTH

- COMMENT
- WPDIST (distance between work points)
- GR_L (gross length of the part)

TIP If you want to display the part mark content in the same order as the switches, set `XS_DIMENSION_PART_MARK_CONTENT_STRICT_POSITION` to `TRUE`.

This advanced option is model specific and the setting is saved in the options database.

Example

```
XS_DIMENSION_PART_MARK_CONTENT_IN_SINGLE=PROFILE_AND_MATERIAL
XS_DIMENSION_PART_MARK_CONTENT_IN_SINGLE=PROFILE_AND_GR_L
```

See also

[XS_DIMENSION_PART_MARK_CONTENT_IN_ASSEMBLY](#) (page 132)

[XS_DIMENSION_PART_MARK_CONTENT_STRICT_POSITION](#) (page 134)

5.40 XS_DIMENSION_PART_MARK_CONTENT_STRICT_POSITION

Category

Dimensioning: Parts

Use for controlling the order of the switches in `XS_DIMENSION_PART_MARK_CONTENT_IN_ASSEMBLY` and `XS_DIMENSION_PART_MARK_CONTENT_IN_SINGLE` and thus the order of the part mark content in assembly and single drawings.

When set to `TRUE`, you can freely select the order of the switches in `XS_DIMENSION_PART_MARK_CONTENT_IN_ASSEMBLY` and `XS_DIMENSION_PART_MARK_CONTENT_IN_SINGLE`, and the part mark content follows the order of the switches. The default value is `FALSE`.

This advanced option is model specific and the setting is saved in the options database.

See also

[XS_DIMENSION_PART_MARK_CONTENT_IN_ASSEMBLY](#) (page 132)

[XS_DIMENSION_PART_MARK_CONTENT_IN_SINGLE](#) (page 133)

5.41 XS_DIMENSION_PLATE_SIDE_MARK_SYMBOL_CENTER

Category

Dimensioning: General

Use this advanced option to define the symbol Tekla Structures uses in center plate side marks. The default value is 1. Tekla Structures uses the symbols defined in `dimension_marks.sym` file located usually in the folder `..\Tekla Structures\<>version>\environments\common\symbols\`.

This advanced option is model specific and the setting is saved in the options database.

5.42 XS_DIMENSION_PLATE_SIDE_MARK_SYMBOL_LEFT

Category

Dimensioning: General

Use this advanced option to define the symbol Tekla Structures uses in left plate side marks. The default value is 0. Tekla Structures uses the symbols defined in `dimension_marks.sym` file located usually in the folder `..\Tekla Structures\<>version>\environments\common\symbols\`.

This advanced option is model specific and the setting is saved in the options database.

5.43 XS_DIMENSION_PLATE_SIDE_MARK_SYMBOL_RIGHT

Category

Dimensioning: General

Use this advanced option to define the symbol Tekla Structures uses in right plate side marks. The default value is 2. Tekla Structures uses the symbols defined in `dimension_marks.sym` file located usually in the folder `..\Tekla Structures\<>version>\environments\common\symbols\`.

This advanced option is model specific and the setting is saved in the options database.

5.44 XS_DIMENSION_SKEWED_BOLTS_IN_PART_PLANE_IN_SINGLE_DRAWINGS

Category

Dimensioning: Bolts

Set this advanced option to `TRUE` to dimension bolts perpendicular to the part plane in single-part drawings. If you do not want to do this, set it to `FALSE`. The default value is `TRUE`.

This advanced option is model specific and the setting is saved in the options database.

5.45 XS_DIR

This advanced option is deprecated. You can still use it in Tekla Structures version 2022 and older Tekla Structures versions. Instead of this advanced option, we recommend that you use [XSDATADIR \(page 114\)](#) to find the root location for the installation, or [XSBIN \(page 68\)](#) to find the location where binaries are found.

This advanced option must be set in an initialization (.ini) file.

This advanced option points to the folder for Tekla Structures data, source, and binary files.

This advanced option is system specific and is read from `teklastructures.ini`. Generally, there is no need to modify system-specific settings. Do not modify them if you are not an administrator.

5.46 XS_DISABLE_ADVANCED_OPTIONS

This advanced option must be set in an initialization (.ini) file.

You can disable the **Advanced options** dialog box so that the advanced options can be edited only in the initialization files.

To disable the dialog box, set this advanced option to `TRUE`. If you do not want to disable the dialog box, set it to `FALSE`. The default value is `FALSE`.

5.47 XS_DISABLE_ANALYSIS_AND_DESIGN

Category: Analysis & Design

Set to `TRUE` to disable the following analysis and design tools from the Tekla Structures user interface:

- The commands from the **Analysis & Design** ribbon tab
- The parts' analysis property dialog boxes
- The **Analysis** tab from the parts' user-defined attributes

The default value is `FALSE`.

This advanced option is user specific and the setting is saved in `options.bin` under the user folder, for example, in `C:\Users\\AppData\Local\Trimble\Tekla Structures\\UserSettings`. Restart Tekla Structures to activate the new value.

5.48 XS_DISABLE_CANCEL_DIALOG_FOR_SAVE_NUMBERING_SAVE

Category

Numbering

Use to revert to the old numbering functionality that offers no option to cancel numbering before the second save is made. The default value is `FALSE`.

This advanced option is model specific and the setting is saved in the options database.

5.49 XS_DISABLE_CLASSIFIER_FOR_MODIFIED_PARTS

Category: Drawing properties

Use to disable the Detailed object level settings check for modified parts. When you change part properties in a model after you have defined the Detailed object level settings, part presentation and mark content are updated in general arrangement drawings unless you have set this advanced option to `TRUE`.

To disable the check for modified parts, set the advanced option to `TRUE`.

To enable the check for modified parts, set the advanced option to `FALSE`. The default value is `FALSE`.

This advanced option is user specific and the setting is saved in `options.bin` under the user folder, for example, in `C:\Users\\AppData\Local\Trimble\Tekla Structures\\UserSettings`. Restart Tekla Structures to activate the new value.

5.50 XS_DISABLE_DRAWING_PLOT_DATE

Category

Drawing Properties

Set this advanced option to `TRUE` to disable the print date information in drawings. Disabling the print date helps to avoid possible conflicts when working with multi-user models in situations where a user modifies drawings while another user prints the same drawings. Set to `FALSE` to have the print date information.

By default, the advanced option is set to `TRUE`.

This advanced option is model specific and the setting is saved in the options database.

5.51 XS_DISABLE_PARTIAL_REFRESH

Category

Model View

Set this advanced option to `TRUE` to disable partial refreshing of OpenGL windows. This advanced option is for older ATI graphics cards. If you do not want to disable the partial refresh, set the advanced option to `FALSE`.

This advanced option is user specific and the setting is saved in `options.bin` under the user folder, for example, in `C:\Users\\AppData\Local\Trimble\Tekla Structures\\UserSettings`. Restart Tekla Structures to activate the new value.

5.52 XS_DISABLE_REBAR_MODELING

Category

Analysis & Design

If you set this advanced option to `TRUE`, Tekla Structures removes reinforcing bar modeling module, even if your subscription includes this module. The subscription always includes this module, except in the Viewer configuration. The default is `FALSE`.

This advanced option is user specific and the setting is saved in `options.bin` under the user folder, for example, in `C:\Users\\AppData\Local\Trimble\Tekla Structures\\UserSettings`. Restart Tekla Structures to activate the new value.

5.53 XS_DISABLE_TEMPLATE_DOUBLE_CLICK

Category: Drawing properties

By default, you are allowed to edit drawing templates and table layouts. It is possible to prevent the template and table layout editing by setting the advanced option `XS_DISABLE_TEMPLATE_DOUBLE_CLICK` to `TRUE`. When you do this:

- You cannot start editing templates or table layouts by double-clicking a template in a drawing. Instead, the **Drawing properties** dialog box will be displayed.
- You cannot start editing templates or table layout by right-clicking a template in a drawing and selecting the corresponding commands.

This advanced option is user specific and the setting is saved in `options.bin` under the user folder, for example, in `C:\Users\\AppData\Local\Trimble\Tekla Structures\\UserSettings`. Restart Tekla Structures to activate the new value.

5.54 XS_DISABLE_VIEW_CENTERING_ASSEMBLY

Category: Drawing views

Use to left-align and/or top-align assembly drawing views. To align the views to left, enter `HOR`, and to align the views to top, enter `VER`. To align the views to left and top, enter both values separated by a space, `HOR VER`, or `TRUE`. To create centered views, leave this advanced option empty or enter `FALSE`.

This advanced option is model specific and the setting is saved in the options database.

5.55 XS_DISABLE_VIEW_CENTERING_GA

Category: Drawing views

Use to left-align or top-align GA drawing views. To align the views to left, enter `HOR`, and to align the views to top, enter `VER`. To align the views to left and top, enter both values separated by a space, `HOR VER`, or `TRUE`. To create centered views, leave this advanced option empty or enter `FALSE`.

This advanced option is model specific and the setting is saved in the options database.

5.56 XS_DISABLE_VIEW_CENTERING_MULTI

Category: Drawing views

Use to left-align or top-align multidrawing views. To align the views to left, enter `HOR`, and to align the views to top, enter `VER`. To align the views to left and top, enter both values separated by a space, `HOR VER`, or `TRUE`. To create centered views, leave this advanced option empty or enter `FALSE`.

This advanced option is model specific and the setting is saved in the options database.

5.57 XS_DISABLE_VIEW_CENTERING_SINGLE

Category: Drawing views

Use to left-align or top-align single-part drawing views. To align the views to left, enter `HOR`, and to align the views to top, enter `VER`. To align the views to left and top, enter both values separated by a space, `HOR VER`, or `TRUE`. To create centered views, leave this advanced option empty or enter `FALSE`.

This advanced option is model specific and the setting is saved in the options database.

5.58 XS_DISPLAY_DIMENSIONS_WHEN_CREATING_OBJECTS

Category

Model View

Use for defining whether dimensions and dimension lines are displayed when model objects are created.

When set to `TRUE` (default), Tekla Structures displays the dimensions and dimension lines.

Dimensions and dimension lines are displayed when you create a new model object and pick the start point and the intermediate or end points for the object.

If you set this advanced option to `FALSE`, the dimensions are not displayed.

This advanced option is user specific and the setting is saved in `options.bin` under the user folder, for example, in `C:\Users\<user>\AppData\Local\Trimble\Tekla Structures\<version>\UserSettings`. Restart Tekla Structures to activate the new value.

5.59 XS_DISPLAY_DIMENSIONS_WHEN_SELECTING_OBJECTS

Category: Model views

Use for defining whether dimensions and dimension lines are displayed when you select a column or a beam.

When this advanced option is set to `TRUE` (default), Tekla Structures displays the dimensions and dimension lines.

Dimensions and dimension lines are displayed when you select a single object, or when you select multiple objects by picking them. The dimensions are not displayed if a command is running, or if you select multiple objects with area selection.

When this advanced option is set to `FALSE`, the dimensions and dimension lines are not displayed.

This advanced option is user specific and the setting is saved in `options.bin` under the user folder, for example, in `C:\Users\<user>\AppData\Local\Trimble\Tekla Structures\<version>\UserSettings`. Restart Tekla Structures to activate the new value.

NOTE When direct modification is switched on, the standard object dimensions and dimension lines are always hidden, regardless of these settings. Only the direct modification dimensions are then shown. This makes it easier to know which dimensions can be edited.

See also

[XS_DISPLAY_DIMENSIONS_WHEN_SELECTING_REBARS \(page 141\)](#)

[XS_DISPLAY_DIMENSIONS_WHEN_CREATING_OBJECTS \(page 140\)](#)

5.60 XS_DISPLAY_DIMENSIONS_WHEN_SELECTING_REBARS

Category: Model views

Use for defining whether dimensions and dimension lines are displayed when you select a reinforcing bar, bar group, or rebar set.

When this advanced option is set to `TRUE` (default), Tekla Structures displays the leg dimensions, total bar length (Σ), and dimension lines. For bar groups, including rebar sets, the dimensions of the first bar and the last bar are displayed. If you select individual bars in rebar sets, the dimensions of all the selected rebar set bars are displayed. Dimensions are not displayed for curved or circular bars, or for hooks.

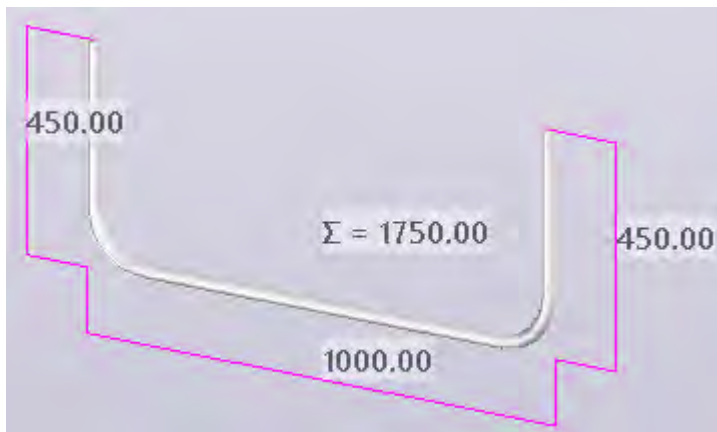

For single reinforcing bars and bar groups, these dimensions are only displayed when direct modification is switched off. When direct modification is switched on, these dimensions are always hidden, and the direct modification dimensions are shown instead. This makes it easier to know which dimensions can be edited.

Dimensions and dimension lines are displayed when you select a single object, or when you select multiple objects by picking them. The dimensions are not displayed if a command is running, or if you select multiple objects with area selection.

When this advanced option is set to `FALSE`, the dimensions and dimension lines are not displayed.

This advanced option is user specific and the setting is saved in `options.bin` under the user folder, for example, in `C:\Users\<user>\AppData\Local\Trimble\Tekla Structures\<version>\UserSettings`.

TIP To quickly switch between the values `TRUE` and `FALSE`, go to the **Rebar** tab on the ribbon and click **Visibility** --> **Rebar dimensions**, or use the keyboard shortcut **Alt+6**.

See also

[XS_DISPLAY_DIMENSIONS_WHEN_SELECTING_OBJECTS](#) (page 141)

5.61 XS_DISPLAY_FILLET_EDGES

Category: Model View

Use this advanced option to show or hide fillet edges in model views. The default value is `TRUE`, which shows the fillet edges. If you do not want to show the fillet edges, set this advanced option to `FALSE`.

Fillet edges are lines that define the boundary between flat faces and curved faces in the model. Examples of model objects containing fillet edges are profiles with curved fillets, slabs or contour plates with curved chamfers, and curved polybeams.

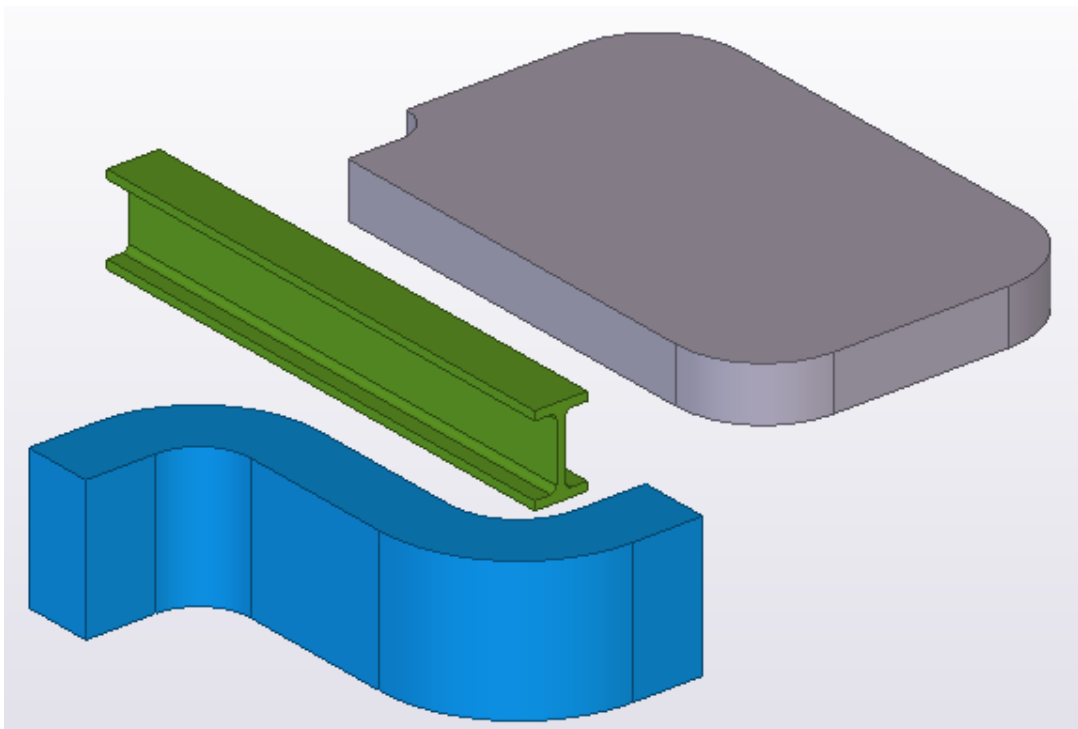

The fillet edges in certain profiles are shown in model views only when you show parts with high accuracy.

This advanced option is user specific, and the setting is saved in `options.bin` under the user folder. Reopen the model to activate the new value.

See also

[XS_SOLID_USE_HIGHER_ACCURACY](#) (page 444)

5.62 XS_DISPLAY_ZERO_INCHES

Category: Imperial units

Set this advanced option to `TRUE` to display zero inches. The default value is `FALSE`.

Using this advanced option affects the results you get with the inquire tool, and the dimensions in the model and drawings.

Example:

`TRUE`: 2'-0"

`FALSE`: 2'

This advanced option is model specific and the setting is saved in the options database.

5.63 XS_DISTANT_OBJECT_FINDER_TOLERANCE

Category

Model View

Use to set the minimum distance from the nearest part for the reporting of distant objects. The object must be located outside this distance for it to be listed by the **Find Distant Objects** tool.

The distance is measured from the nearest part. Enter the value in meters. The default value is 100.

This advanced option is model specific and the setting is saved in the options database.

See also

5.64 XS_DO_NOT_CLIP_NATIVE_OBJECTS_WITH_CLIP_PLANE

Category: Model views

Set this advanced option to `TRUE` to only clip point clouds and reference models with the **Clip plane** command. Native Tekla Structures objects are not clipped. `FALSE` is the default value.

Redraw the model views after changing the value.

This advanced option is user specific and the setting is saved in `options.bin` under the user folder.

5.65 XS_DO_NOT_CREATE_ASSEMBLY_DRAWINGS_FOR_CONCRETE_PARTS

Category

Drawing Properties

Use to control the creation of single-part and assembly drawings from concrete parts.

To enable the creation of drawings, set the advanced option to `FALSE`.

To disable the creation of drawings, set the advanced option to `TRUE` (default).

This advanced option is model specific and the setting is saved in the options database.

5.66 XS_DO_NOT_CREATE_ASSEMBLY_DRAWINGS_FOR_LOOSE_PARTS

Category

Drawing Properties

Use this advanced option for defining whether assembly drawings are created for assemblies that contain only one part.

When you set this advanced option to `TRUE`, Tekla Structures does not create assembly drawings for single-part assemblies. The default value is `FALSE`.

This advanced option is model specific and the setting is saved in the options database.

5.67 XS_DO_NOT_CREATE_BOLT_MARKS_IN_ALL_INCLUDED_SINGLE_VIEWS

Category

Single Part View in Assembly Drawing

Use to prevent the creating of bolt marks in included single views.

Enter `TRUE` to exclude the bolt marks, `FALSE` to create the bolt marks. The default is `FALSE`.

This advanced option is user specific and the setting is saved in `options.bin` under the user folder, for example, in `C:\Users\\AppData\Local\Trimble\Tekla Structures\\UserSettings`. Restart Tekla Structures to activate the new value.

5.68 XS_DO_NOT_CREATE_PART_MARKS_IN_ALL_INCLUDED_SINGLE_VIEWS

Category

Single Part View in Assembly Drawing

Use to prevent the creating of part marks in included single part views.

Enter `TRUE` to exclude the part marks and `FALSE` to create the part marks. The default is `FALSE`.

This advanced option is user specific and the setting is saved in `options.bin` under the user folder, for example, in `C:\Users\\AppData\Local\Trimble\Tekla Structures\\UserSettings`. Restart Tekla Structures to activate the new value.

5.69 XS_DO_NOT_CREATE_PROFILE_DIMENSIONS_FOR_CONCRETE

Contents

Drawing Properties

Set this advanced option to `TRUE` to prevent Tekla Structures from automatically displaying the profile dimensions of concrete parts in cast unit drawings. If you want to display the profile dimensions, set it to `FALSE`.

This advanced option is model specific and the setting is saved in the options database.

5.70 XS_DO_NOT_DISPLAY_CHAMFERS

Category: Model View

Set this advanced option to `TRUE` to draw polygon plates without chamfer lines. If you want to display the chamfer lines, set this advanced option to `FALSE`. The default value is `FALSE`.

This advanced option works with [XS_DRAW_CHAMFERS_HANDLES](#) (page 163) set to `CHAMFERS` or to `CHAMFERS_AND_HANDLES`.

This advanced option is user specific and the setting is saved in `options.bin` under the user folder, for example, in `C:\Users\\AppData\Local\Trimble\Tekla Structures\\UserSettings`. Restart Tekla Structures to activate the new value.

5.71 XS_DO_NOT_DRAW_COLUMN_MARKS_AT_45_DEGREES_IN_GA_DRAWING

Category

Marking: Parts

Tekla Structures places column mark texts in general arrangement drawing plan views by default at an angle of 45 degrees in respect to the position of the column. To place the marks horizontally, set this advanced option to `TRUE`. If you set this advanced option to `FALSE`, the mark texts are placed at the angle of 45 degrees. The default value is `TRUE`.

This advanced option is model specific and the setting is saved in the options database.

Example

In the following example, the advanced option is set to `TRUE`.

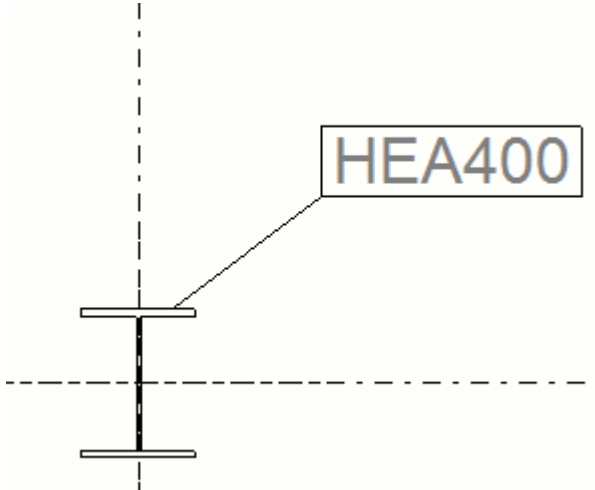

In the following example, the advanced option is set to `FALSE`.

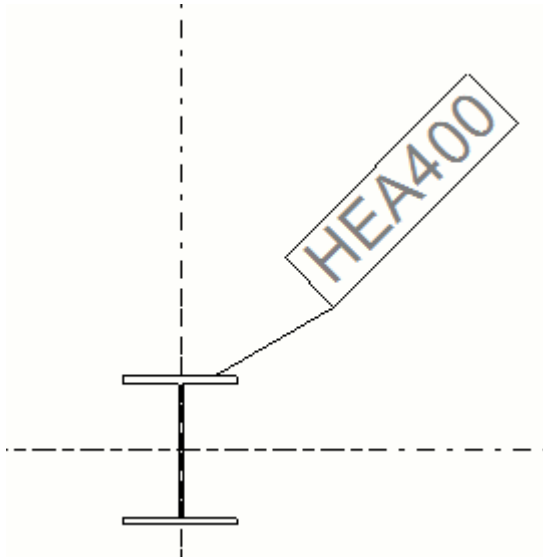

5.72 XS_DO_NOT_EXTEND_DIMENSION_LINES_THROUGH_ALL_HOLES

Category

Dimensioning: Bolts

Set this advanced option to `TRUE` (default) to prevent dimension lines from extending through all holes in a bolt group. If you wish to extend the dimension lines, set this advanced option to `FALSE`.

This advanced option is model specific and the setting is saved in the options database.

5.73 XS_DO_NOT_PLOT_DIMENSION_POINT_CIRCLES

Category: Dimensioning: General

Set to `TRUE` to prevent Tekla Structures from printing red dimension point invalidity symbols when you print from **Document manager**. Dimension point invalidity symbols are always printed if you have a drawing open. The default value is `FALSE`.

This advanced option is user specific and the setting is saved in `options.bin` under the user folder, for example, in `C:\Users\\AppData\Local\Trimble\Tekla Structures\\UserSettings`. Restart Tekla Structures to activate the new value.

5.74 XS_DO_NOT_OVERWRITE_PLUGIN_INP_FILE

Category

This advanced option must be set in an initialization (.ini) file.

With standard settings Tekla Structures overwrites the step profile settings and replaces them with the default values every time when Tekla Structures is started. To prevent Tekla Structures from losing the step profile settings, set the advanced option `XS_DO_NOT_OVERWRITE_PLUGIN_INP_FILE` to `TRUE` in the `teklastructures.ini` file.

If you are using catalog step profiles and have set `XS_DO_NOT_OVERWRITE_PLUGIN_INP_FILE` to `TRUE` and you update Tekla Structures, do the following:

1. Set `XS_DO_NOT_OVERWRITE_PLUGIN_INP_FILE` to `FALSE` in `teklastructures.ini` file.
2. Update Tekla Structures.
3. Start Tekla Structures.
4. Set `XS_DO_NOT_OVERWRITE_PLUGIN_INP_FILE` to `TRUE` in `teklastructures.ini` file.
5. Run `Steps.exe`.
6. Restart Tekla Structures.

See also

5.75 XS_DO_NOT_REMOVE_END_ABSOLUTE_DIMENSIONS

Category

Dimensioning: Parts

When you use absolute dimensions, Tekla Structures removes the last absolute vertical dimension. To prevent this, set this advanced option to `TRUE` (default). If you do not want to do this, set this advanced option to `FALSE`.

Note that `XS_DO_NOT_REMOVE_END_ABSOLUTE_DIMENSIONS` only works when the dimensioning type is **Integrated dimensions**.

This advanced option is model specific and the setting is saved in the options database.

| Setting | Example of appearance in drawings |
|---------|-----------------------------------|
| TRUE | |
| FALSE | |

5.76 XS_DO_NOT_USE_FOLDED_GUSSET_PLATE

This advanced option must be set in an initialization (.ini) file.

Set this advanced option to `TRUE` to use part-adds to create bent plates in gusset connections. If you set it to `FALSE`, Tekla Structures creates bent gusset plates using the **Polybeam** command instead of the **Part-add** command.

5.77 XS_DO_NOT_USE_GLOBAL_PLATE_SIDE

Category

Components

By default, connections 141, 146, 147, 149, 181, 184, 185, 186 and 187 create all shear tabs on the same side of the main part if the main part has several connections (global positioning). Set this advanced option to `TRUE` to position each shear tab according to which end of the main part the connection that creates it is closest to (local positioning). The default value is `FALSE`.

This advanced option is model specific and the setting is saved in the options database.

5.78 XS_DONT_SHOW_POLYBEAM_MID_EDGES

Category: Drawing properties

Set this advanced option to `TRUE` to hide polybeam fold and bend lines in drawings. If you set it to `FALSE` (default), the fold and bend lines are shown.

This advanced option is user specific and the setting is saved in `options.bin` under the user folder, for example, in `C:\Users\<user>\AppData\Local\Trimble\Tekla Structures\<version>\UserSettings`.

Example

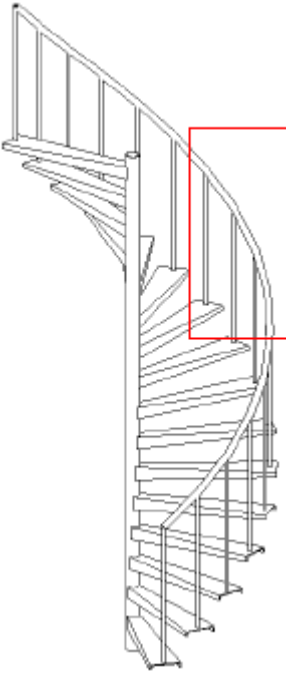
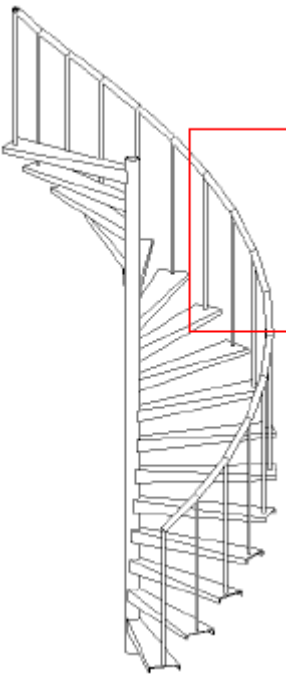
| Advanced option is set to | Example | Description |
|---------------------------|---|---|
| TRUE |  | Polybeam fold and bend lines are not shown in the handrail. |
| FALSE |  | Polybeam fold and bend lines are shown in the handrail. |

5.79 XS_DRAW_ALL_SECTION_EDGES_IN_DRAWINGS

Category

Drawing Properties

Set this advanced option to `TRUE` to draw the edges of a cut part in the drawing and to `FALSE` to leave the edges open. The default value is `TRUE`.

This advanced option is model specific and the setting is saved in the options database.

See also

[XS_SECTION_LINE_COLOR](#) (page 395)

5.80 XS_DRAW_ANGLE_AND_RADIUS_INFO_IN_UNFOLDING

Category: Dimensioning - unfolding

Set this advanced option to `TRUE` to show the angle and radius information on the dimension line. The default for this advanced option is that the information is shown. To hide this information, set it to `FALSE`.

This advanced option is model specific and the setting is saved in the options database.

5.81 XS_DRAW_BENDING_END_LINE_DIMENSIONS_IN_UNFOLDING

Category: Dimensioning - unfolding

Set this advanced option to `TRUE` to create bending end line dimensions when creating unfolded single-part drawings. The default value is `FALSE`.



Note that two different dimensions are created if the advanced option `XS_DRAW_BENDING_LINE_DIMENSIONS_IN_UNFOLDING` is set to `TRUE` as well.

This advanced option is model specific and the setting is saved in the options database.

See also

[XS_DRAW_BENDING_END_LINES_IN_UNFOLDING \(page 154\)](#)

5.82 XS_DRAW_BENDING_END_LINES_IN_UNFOLDING

Category: Dimensioning - unfolding

Set this advanced option to `TRUE` to draw bending end lines when creating unfolded single part drawing of a bent plate or a polybeam. For polybeams, the lines will be drawn only if the polybeam has circular shape chamfers. The default value is `FALSE`.

This advanced option is model specific and the setting is saved in the options database.

See also

[XS_DRAW_BENDING_END_LINE_DIMENSIONS_IN_UNFOLDING \(page 153\)](#)

5.83 XS_DRAW_BENDING_LINE_DIMENSIONS_IN_UNFOLDING

Category: Dimensioning - unfolding

Set this advanced option to `TRUE` to create bending line dimensions in a drawing.

If you do not want to create these dimensions, set this advanced option to `FALSE`. The default value is `TRUE`.

This advanced option is model specific and the setting is saved in the options database.

5.84 XS_DRAW_BOLT_HIDDEN_LINES

Category: Drawing properties

Use the following advanced options to show or hide bolts that are hidden from view by other parts, in single part, assembly, and general arrangement drawings. The default values are shown here:

- XS_DRAW_BOLT_HIDDEN_LINES_IN_SINGLE_DRAWINGS=AS_PART
- XS_DRAW_BOLT_HIDDEN_LINES_IN_ASSEMBLY_DRAWINGS=AS_PART
- XS_DRAW_BOLT_HIDDEN_LINES_IN_GA_DRAWINGS=FALSE

Possible values are:

- AS_PART: uses part's hidden line visibility settings.
- TRUE: always shows hidden bolts.
- FALSE: does not show hidden bolts.

NOTE Tekla Structures sets the way the bolt hidden lines are shown when the bolt is added to a drawing, usually when you create the drawing or a drawing view. The hidden lines setting of the bolts cannot be changed afterwards.

One way to change the setting in an old drawing is to create a new drawing view using the desired bolt hidden lines settings.

Example

The following examples show how these advanced options can be used together with drawing property settings.

| To | Do this |
|--|--|
| Set the hidden lines to be always invisible in assembly drawings | <ol style="list-style-type: none"> 1. In the Assembly Drawing Properties dialog box, click Bolts. 2. On the Content tab, select solid from the Solid/Symbol list. 3. Click OK. 4. Go to File menu --> Settings --> Advanced options --> Drawing Properties, and set XS_DRAW_BOLT_HIDDEN_LINES_IN_ASSEMBLY_DRAWINGS to FALSE. 5. Create the drawing. |
| Set the hidden lines to be visible as the assembly drawing part properties allow | <ol style="list-style-type: none"> 1. In the Assembly Drawing Properties dialog box, click Bolts. 2. On the Content tab, select solid from the Solid/Symbol list. 3. Click OK. 4. Click Part in the drawing properties dialog box. |

| To | Do this |
|----|---|
| | <ol style="list-style-type: none"> <li data-bbox="595 277 1297 342">5. On the Content tab, remove the check mark from the Hidden line on/off check box. <li data-bbox="595 360 1297 501">6. Go to File menu --> Settings --> Advanced options --> Drawing Properties , and set <code>XS_DRAW_BOLT_HIDDEN_LINES_IN_ASSEMBLY_DRAWINGS</code> to <code>AS_PART</code>. <li data-bbox="595 519 927 553">7. Create the drawing. |

See also

[XS_DRAW_BOLT_OWN_HIDDEN_LINES \(page 158\)](#)

5.85 XS_DRAW_BOLT_HIDDEN_LINES_IN_ASSEMBLY_DRAWINGS

Category

Drawing Properties

Use this advanced option to show or hide bolts that are hidden from view by other parts in assembly drawings.

The possible values are:

- `AS_PART`: uses part's hidden line visibility settings.
- `TRUE`: always shows hidden bolts.
- `FALSE`: does not show hidden bolts.

The default value is `AS_PART`.

NOTE This setting only affects bolts with solid or exact solid representation. Bolts with symbol representation are always visible. Changing the advanced option does not affect existing drawings, but you need to recreate them.

This advanced option is role specific. When the type **SYSTEM(ROLE)** is in use, the default value is used. When the type **MODEL(ROLE)** or **DRAWING(ROLE)** is in use, you can change the value, which is then the same for all users in the current model.

See also

[XS_DRAW_BOLT_HIDDEN_LINES \(page 154\)](#).

5.86 XS_DRAW_BOLT_HIDDEN_LINES_IN_GA_DRAWINGS

Category

Drawing Properties

Use this advanced option to show or hide bolts that are hidden from view by other parts in general arrangement drawings.

The possible values are:

- `AS_PART`: uses part's hidden line visibility settings.
- `TRUE`: always shows hidden bolts.
- `FALSE`: does not show hidden bolts.

The default value is `FALSE`.

NOTE This setting only affects bolts with solid or exact solid representation. Bolts with symbol representation are always visible. Changing the advanced option does not affect existing drawings, but you need to recreate them.

This advanced option is role specific. When the type **SYSTEM(ROLE)** is in use, the default value is used. When the type **MODEL(ROLE)** or **DRAWING(ROLE)** is in use, you can change the value, which is then the same for all users in the current model.

See also

[XS_DRAW_BOLT_HIDDEN_LINES](#) (page 154).

5.87 XS_DRAW_BOLT_HIDDEN_LINES_IN_SINGLE_DRAWINGS

Category

Drawing Properties

Use this advanced option to show or hide bolts that are hidden from view by other parts in single part drawings.

The possible values are:

- `AS_PART`: uses part's hidden line visibility settings.
- `TRUE`: always shows hidden bolts.
- `FALSE`: does not show hidden bolts.

The default value is `AS_PART`.

NOTE This setting only affects bolts with solid or exact solid representation. Bolts with symbol representation are always visible. Changing the

advanced option does not affect existing drawings, but you need to recreate them.

This advanced option is model specific and the setting is saved in the options database.

See also

[XS_DRAW_BOLT_HIDDEN_LINES \(page 154\)](#).

5.88 XS_DRAW_BOLT_OWN_HIDDEN_LINES

Category

Drawing properties

Use the following advanced options show or hide own hidden lines in bolts in single part, assembly, and general arrangement drawings. The *own hidden lines* are the lines of the object representation covered up by the object itself.

The default values are shown here:

- XS_DRAW_BOLT_OWN_HIDDEN_LINES_IN_SINGLE_DRAWINGS=AS_PART
- XS_DRAW_BOLT_OWN_HIDDEN_LINES_IN_ASSEMBLY_DRAWINGS=AS_PART
- XS_DRAW_BOLT_OWN_HIDDEN_LINES_IN_GA_DRAWINGS=FALSE

Possible values are:

- AS_PART: used the visibility settings of the part's own hidden lines.
- TRUE: always shows bolts' hidden lines.
- FALSE: does not show bolts' hidden lines.

See also

[XS_DRAW_BOLT_HIDDEN_LINES \(page 154\)](#)

5.89 XS_DRAW_BOLT_OWN_HIDDEN_LINES_IN_ASSEMBLY_DRAWINGS

Category

Drawing Properties

To show or hide the hidden lines of the bolts based on the own hidden line settings of the part that hides the bolts, enter AS_PART. To always show

hidden lines of the hidden bolts, enter `TRUE`. To never show the hidden lines, enter `FALSE`. The default value is `AS_PART`.

This advanced option is role specific. When the type **SYSTEM(ROLE)** is in use, the default value is used. When the type **MODEL(ROLE)** or **DRAWING(ROLE)** is in use, you can change the value, which is then the same for all users in the current model.

See also

[XS_DRAW_BOLT_OWN_HIDDEN_LINES](#) (page 158)

5.90 XS_DRAW_BOLT_OWN_HIDDEN_LINES_IN_GA_DRAWINGS

Category

Drawing Properties

To show or hide the hidden lines of the bolts based on the own hidden line settings of the part that hides the bolts, enter `AS_PART`. To always show hidden lines of the hidden bolts, enter `TRUE`. To never show hidden lines of the hidden bolts, enter `FALSE`. The default value is `FALSE`.

NOTE This setting only affects bolts with solid or exact solid representation. Bolts with symbol representation are always visible. Changing the advanced option does not affect existing drawings, but you need to recreate them.

This advanced option is role specific. When the type **SYSTEM(ROLE)** is in use, the default value is used. When the type **MODEL(ROLE)** or **DRAWING(ROLE)** is in use, you can change the value, which is then the same for all users in the current model.

See also

[XS_DRAW_BOLT_OWN_HIDDEN_LINES](#) (page 158)

5.91 XS_DRAW_BOLT_OWN_HIDDEN_LINES_IN_SINGLE_DRAWINGS

Category

Drawing Properties

To show or hide the hidden lines of the bolts based on the own hidden line settings of the part that hides the bolts, enter `AS_PART`. To always show

hidden lines of the hidden bolts, enter `TRUE`. To never show hidden lines of the hidden bolts, enter `FALSE`. The default value is `AS_PART`.

NOTE This setting only affects bolts with solid or exact solid representation. Bolts with symbol representation are always visible. Changing the advanced option does not affect existing drawings, but you need to recreate them.

This advanced option is model specific and the setting is saved in the options database.

See also

[XS_DRAW_BOLT_OWN_HIDDEN_LINES](#) (page 158)

5.92 XS_DRAW_BOLTS_3D_IN_BOLT_LAYER

Category: Model views

When this advanced option is set to `TRUE`, which is the default value, the model views that display bolts as rendered solid objects (using the **Exact** representation option) open and update faster. This is especially useful in large models with steel structures.

This advanced option is system specific and is read from environment files. It can also be read from `teklastructures.ini`. Generally, there is no need to modify system-specific settings. Do not modify them if you are not an administrator.

After changing the value of this advanced option, first save the model. Then restart Tekla Structures to activate the new setting.

5.93 XS_DRAW_BOLTS_PERPENDICULAR_TO_PART_IN_SINGLE_DRAWINGS

Category: Dimensioning - bolts

Set this advanced option to `TRUE` to draw bolts perpendicular to the part plane in single part drawings. If you do not want to do this, set it to `FALSE`. This only applies to bolt symbol types **symbol** and **symbol3**. `FALSE` is the default value.

Note that this advanced option also affects how bolts are shown in single-part drawings included in multi-drawings, and in single-part views in assembly drawings.

This advanced option is model specific and the setting is saved in the options database.

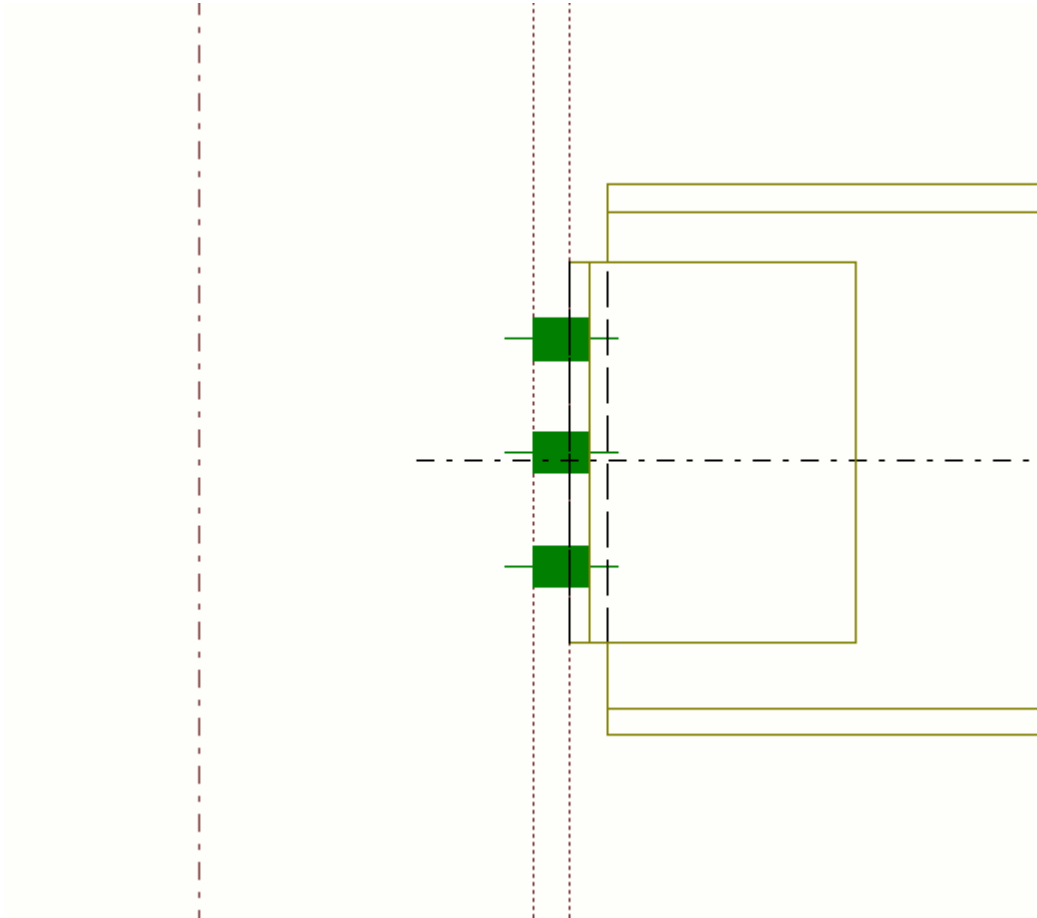

5.95 XS_DRAW_CAST_PHASE_INTERNAL_LINES

Category: Concrete detailing

Use to show or hide edge lines of (precast) concrete cast units in drawings. Set to `TRUE` (default) to show overlapping edge lines between adjacent cast units that are in the same phase.

NOTE If you are working with cast-in-place concrete parts and `XS_ENABLE_POUR_MANAGEMENT` is set to `TRUE`, the advanced options `XS_DRAW_CAST_UNIT_INTERNAL_LINES` and `XS_DRAW_CAST_PHASE_INTERNAL_LINES` do not have an effect.

If `XS_ENABLE_POUR_MANAGEMENT` is set to `FALSE`, both cast-in-place and precast concrete parts are treated in the same way and are affected by the advanced options

XS_DRAW_CAST_UNIT_INTERNAL_LINES and
XS_DRAW_CAST_PHASE_INTERNAL_LINES.

This advanced option is role specific. When the type **SYSTEM(ROLE)** is in use, the default value is used. When the type **MODEL(ROLE)** or **DRAWING(ROLE)** is in use, you can change the value, which is then the same for all users in the current model.

See also

[XS_DRAW_CAST_UNIT_INTERNAL_LINES \(page 163\)](#)

5.96 XS_DRAW_CAST_UNIT_INTERNAL_LINES

Category: Concrete Detailing

Use to show or hide concrete part lines inside (precast) cast units in drawings. Set to `TRUE` to show overlapping part lines inside cast units.

The default value is `FALSE`.

NOTE If you are working with cast-in-place concrete parts and `XS_ENABLE_POUR_MANAGEMENT` is set to `TRUE`, the advanced options `XS_DRAW_CAST_UNIT_INTERNAL_LINES` and `XS_DRAW_CAST_PHASE_INTERNAL_LINES` do not have an effect.

If `XS_ENABLE_POUR_MANAGEMENT` is set to `FALSE`, both cast-in-place and precast concrete parts are treated in the same way and are affected by the advanced options

`XS_DRAW_CAST_UNIT_INTERNAL_LINES` and
`XS_DRAW_CAST_PHASE_INTERNAL_LINES`.

This advanced option is model specific and the setting is saved in the options database.

See also

[XS_DRAW_CAST_PHASE_INTERNAL_LINES \(page 162\)](#)

5.97 XS_DRAW_CHAMFERS_HANDLES

Category: Model view

Use to define whether to show the handles or the chamfers for contour plates, concrete slabs, and polybeams. The options are:

- **HANDLES:** handles are shown. Makes the selection of handles easier. This is the default value.

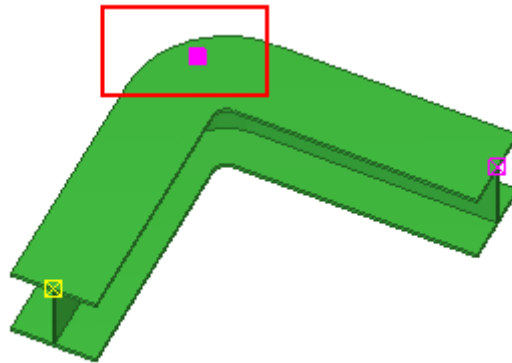

- **CHAMFERS:** chamfers are shown. Use this option, for example, when you want to check the status of polybeam chamfers.

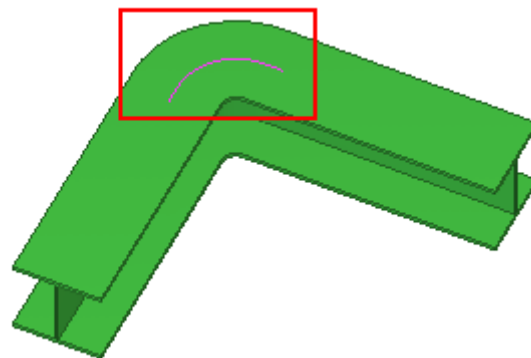

- **CHAMFERS_AND_HANDLES** shows both the chamfers and handles.

See also

[XS_DO_NOT_DISPLAY_CHAMFERS](#) (page 146)

5.98 XS_DRAW_CROSS_AXIS

Category

Drawing properties

Set to **N** to have Tekla Structures hide the axis cross in beam cross sections.

Leave the value out to display the axis cross in beam cross sections.

This advanced option is model specific and the setting is saved in the options database.

5.99 XS_DRAW_CUT_FACES_WITH_OBJECT_COLOR

Category: Model views

Set to `FALSE` (default) to have cut faces shown in gray, and to `TRUE` to show the cut faces with the same color as the other object faces.

Redraw the model view after changing the value for the change to take effect.

This advanced option is user specific and the setting is saved in `options.bin` under the user folder, for example, in `C:\Users\\AppData\Local\Trimble\Tekla Structures\\UserSettings`.

5.100 XS_DRAW_HIDDEN_FACES

Category: Drawing Properties

Set this advanced option to `TRUE` to draw hidden part faces in drawings. The default value is `FALSE`. This advanced option hides the hatches on the hidden part faces, for example.

This advanced option is model specific and the setting is saved in the options database.

Example of using the value `TRUE`:

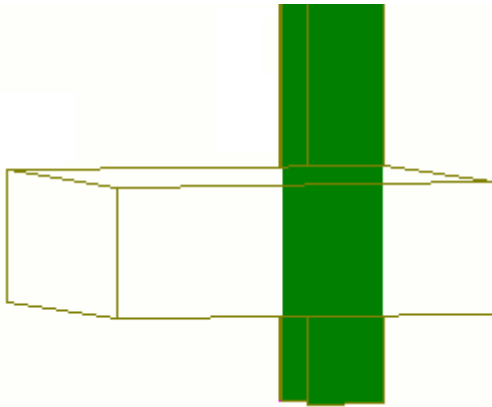

Example of using the value `FALSE`:

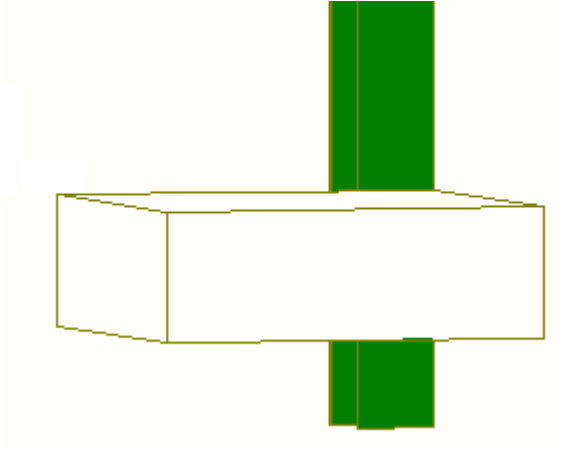

TIP To hide hidden faces of rebars, use the advanced option [XS_DRAW_REBAR_HIDDEN_FACES](#) (page 167).

5.101 XS_DRAW_HORIZONTAL_VIEW_SHORTENING_SYMBOLS_TO_PARTS

Category

Drawing Properties

Set to `TRUE` to show horizontal view shortening symbols automatically. The default value is `FALSE`.

This advanced option is role specific. When the type **SYSTEM(ROLE)** is in use, the default value is used. When the type **MODEL(ROLE)** or **DRAWING(ROLE)** is in use, you can change the value, which is then the same for all users in the current model.

Limitations

- Shortening symbols are not shown in general arrangement drawings.
- Shortening symbols are not shown in rectangular hollow sections or channel sections.

See also

[XS_DRAW_VERTICAL_VIEW_SHORTENING_SYMBOLS_TO_PARTS](#) (page 172)

[XS_SHORTENING_SYMBOL_WITH_ZIGZAG](#) (page 417)

[XS_SHORTENING_SYMBOL_COLOR](#) (page 417)

[XS_SHORTENING_SYMBOL_LINE_TYPE](#) (page 417)

5.102 XS_DRAW_INSIDE_ANGLE_IN_UNFOLDING

Category: Dimensioning - unfolding

Set this advanced option to `TRUE` to display the interior angle instead of the exterior angle in angle text. If set this advanced option to `FALSE` (default), the exterior angle is displayed.

This advanced option is model specific and the setting is saved in the options database.

5.103 XS_DRAW_LONG_HOLE_DIMENSIONS

Category

Dimensioning: Bolts

Set this advanced option to `TRUE` to dimension slotted holes to the center points of the curve. If you set this advanced option to `FALSE` (default), the slotted holes are dimensioned to the center points of the holes.

This advanced option is model specific and the setting is saved in the options database.

5.104 XS_DRAW_MESH_OUTLINE_SYMBOL _FROM_BOTTOM_LEFT_TO_TOP_RIGHT

Category

Concrete Detailing

Use to define the outline representation of reinforcement meshes in drawings. When you set this advanced option to `TRUE` (default), the outline representation symbol of the mesh is always from bottom left to top right.

This advanced option is model specific and the setting is saved in the options database.

5.105 XS_DRAW_REBAR_HIDDEN_FACES

Category: Drawing properties

Use this advanced option to control the display of the rebar hidden faces in drawings. To show the hidden faces of the rebars, set this advanced option to TRUE. FALSE is the default value.

This advanced option is model specific and the setting is saved in the options database.

In the first image below, XS_DRAW_REBAR_HIDDEN_FACES has been set to TRUE.

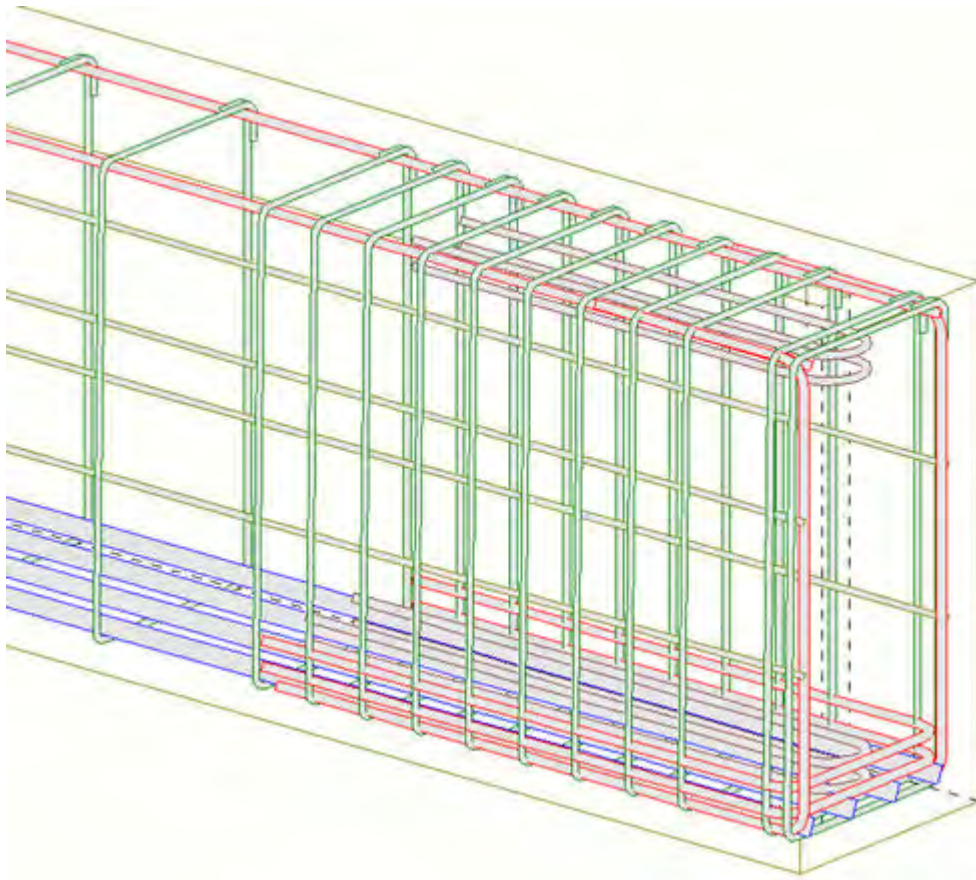

In the image below, XS_DRAW_REBAR_HIDDEN_FACES has been set to FALSE.

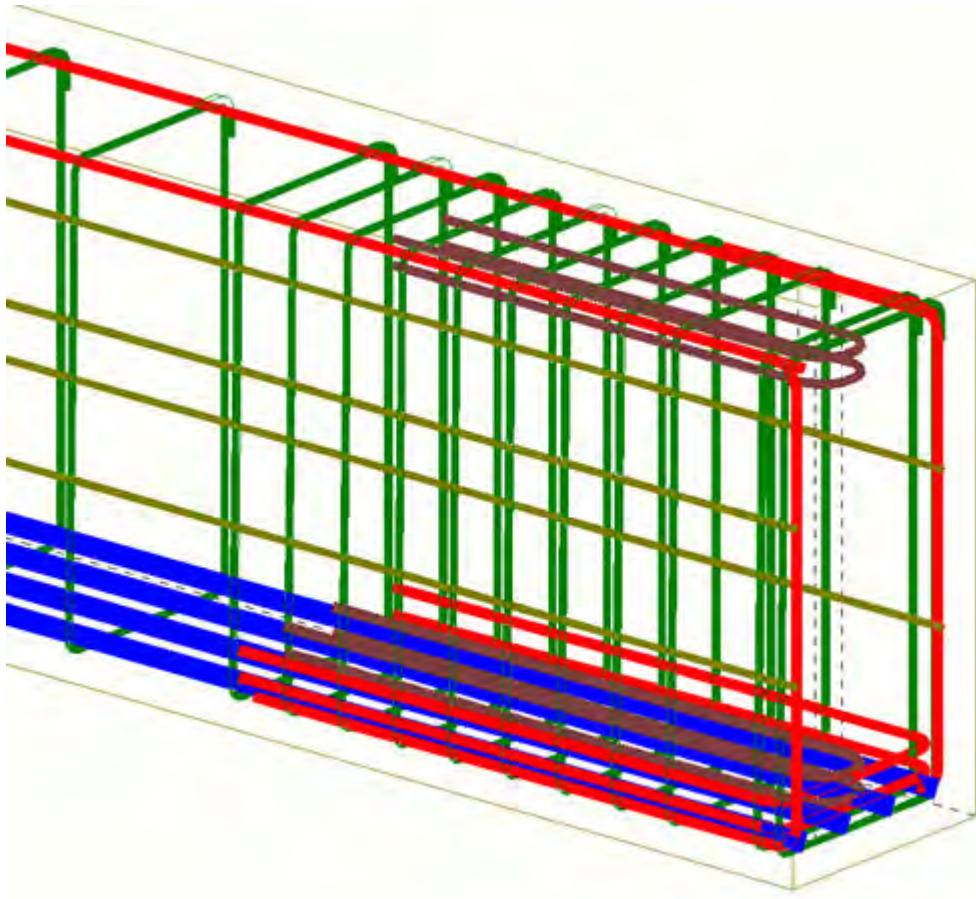

This advanced option is model specific and the setting is saved in the options database.

See also

[XS_DRAW_HIDDEN_FACES \(page 165\)](#)

5.106 XS_DRAW_REBAR_SELF_INTERSECTING_LEGS_WITH_OFFSET

Category: Drawing properties

When set to `TRUE`, this advanced option displays rebars in drawings with overlap in all representations. Note that `FALSE` has no impact on the **filled line** representation. The default value is `FALSE`.

This advanced option is model specific and the setting is saved in the options database.

`XS_DRAW_REBAR_SELF_INTERSECTING_LEGS_WITH_OFFSET` set to `TRUE`:

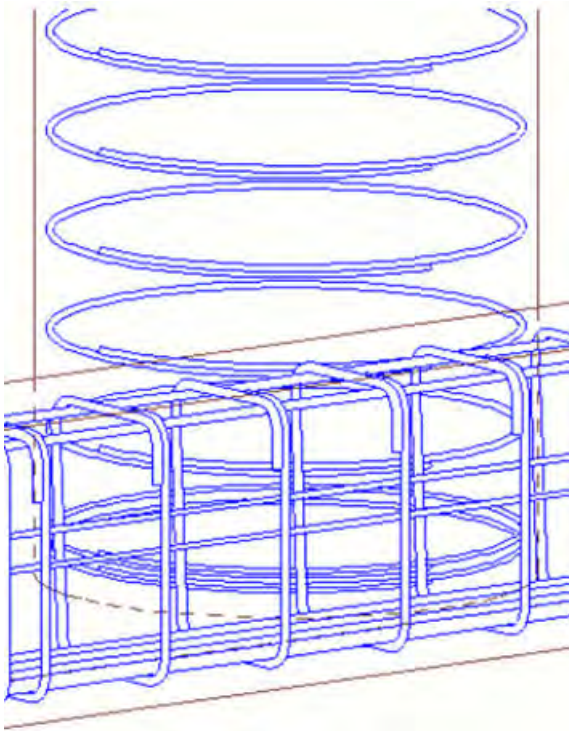

XS_DRAW_REBAR_SELF_INTERSECTING_LEGS_WITH_OFFSET set to FALSE:

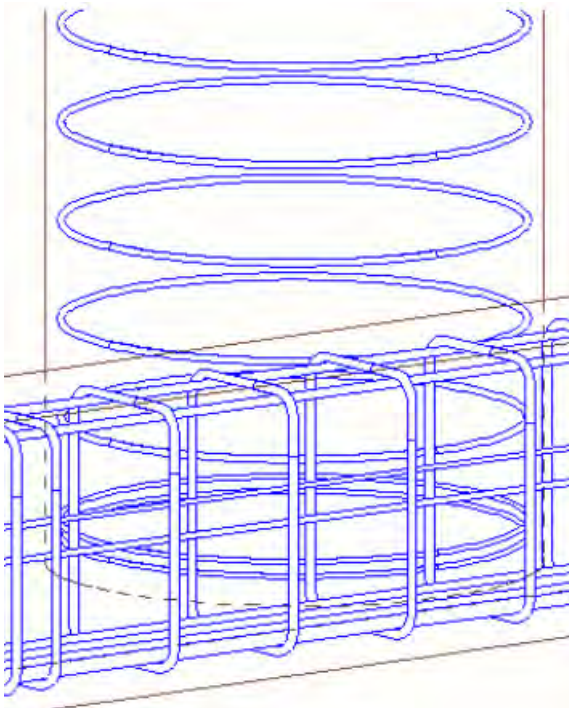

5.107 XS_DRAW_ROOT_OPENING_EVEN_WHEN_ZERO

Category: Welds

Set this advanced option to `TRUE` to show zero root openings in welds. The default is `TRUE`. If you set this advanced option to `FALSE`, the zero root openings are not shown.

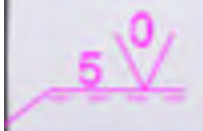

Root opening is the space between welded parts. Root opening value is only shown for weld types 3 and 4 (bevel-groove single-V butt and bevel-groove single-bevel butt welds).

This advanced option is role specific. When the type **SYSTEM(ROLE)** is in use, the default value is used. When the type **MODEL(ROLE)** or **DRAWING(ROLE)** is in use, you can change the value, which is then the same for all users in the current model.

5.108 XS_DRAW_SHORT_LEADER_LINES_OF_PART_MARKS

Category

Marking: Parts

Use this advanced option to define if a leader line is drawn when the leader line is shorter than defined with the advanced option `XS_DRAW_SHORT_LEADER_LINES_OF_PART_MARKS_MINIMUM_LENGTH`. When you set this option to `FALSE`, the leader line is not drawn. Set to `TRUE` (default) to always draw leader lines in part marks.

This advanced option is model specific and the setting is saved in the options database.

See also

[XS_DRAW_SHORT_LEADER_LINES_OF_PART_MARKS_MINIMUM_LENGTH](#)
(page 171)

5.109 XS_DRAW_SHORT_LEADER_LINES_OF_PART_MARKS_MINIMUM_LENGTH

Category

Marking: Parts

Use this advanced option to define the minimum length of a leader line that Tekla Structures draws. If the leader line is shorter than the minimum length and the advanced option `XS_DRAW_SHORT_LEADER_LINES_OF_PART_MARKS` is set to `FALSE`, the leader line is not drawn. The default value is `0.0`. If the advanced option

`XS_DRAW_SHORT_LEADER_LINES_OF_PART_MARKS_MINIMUM_LENGTH` is set to `TRUE`, the part mark leader lines are always drawn.

This advanced option is model specific and the setting is saved in the options database.

See also

[XS_DRAW_SHORT_LEADER_LINES_OF_PART_MARKS \(page 171\)](#)

5.110 XS_DRAW_SKEWED_ELEVATIONS

Category: Dimensioning - parts

Set this advanced option to `TRUE` to display skewed elevation dimensions.

If you set it to `FALSE` (default), skewed elevation dimensions are not displayed in drawings.

This advanced option is model specific and the setting is saved in the options database.

5.111 XS_DRAW_VERTICAL_VIEW_SHORTENING_SYMBOLS_TO_PARTS

Category

Drawing Properties

Set this advanced option to `TRUE` to show vertical view shortening symbols automatically. The default value is `FALSE`.

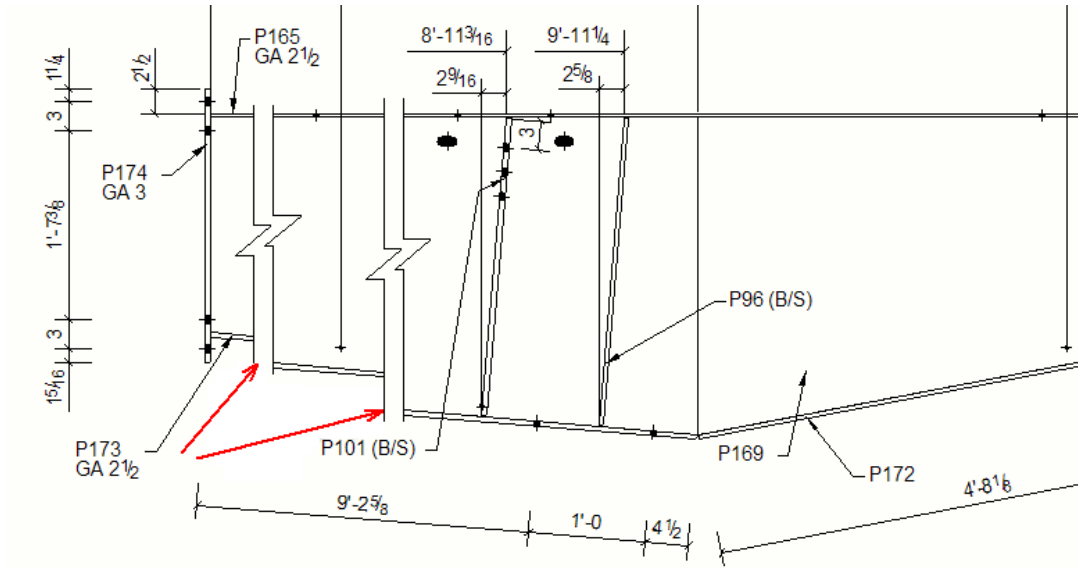

This advanced option is role specific. When the type **SYSTEM(ROLE)** is in use, the default value is used. When the type **MODEL(ROLE)** or **DRAWING(ROLE)** is in use, you can change the value, which is then the same for all users in the current model.

Limitations

- Shortening symbols are not shown in general arrangement drawings.
- Shortening symbols are not shown in rectangular hollow sections or channel sections.

See also

[XS_DRAW_HORIZONTAL_VIEW_SHORTENING_SYMBOLS_TO_PARTS](#) (page 166)

[XS_SHORTENING_SYMBOL_WITH_ZIGZAG](#) (page 417)

[XS_SHORTENING_SYMBOL_COLOR](#) (page 416)

[XS_SHORTENING_SYMBOL_LINE_TYPE](#) (page 417)

5.112 XS_DRAWING_ALLOW_NEW_SECTIONS_IN_REDIMENSIONING

Category

Drawing Properties

Use to define whether new views or sections are created during redimensioning of existing drawings. The default is `FALSE`, which means that no views or sections are created.

This advanced option is role specific. When the type **SYSTEM(ROLE)** is in use, the default value is used. When the type **MODEL(ROLE)** or **DRAWING(ROLE)** is in use, you can change the value, which is then the same for all users in the current model.

5.113 XS_DRAWING_ALLOW_SNAPPING_TO_DISTANT_POINTS

Category

Drawing Properties

Set this advanced option to `TRUE` to allow the cursor to snap to object end points in a drawing even if the cursor is not near the end point. This means that if the cursor is anywhere on the object, the cursor will snap to the object end points. If you do not want to allow this, set this advanced option to `FALSE`. Then the cursor will snap only to the snap points near the cursor.

The default value is `FALSE`.

This advanced option is user specific and the setting is saved in `options.bin` under the user folder, for example, in `C:\Users\\AppData\Local\Trimble\Tekla Structures\\UserSettings`. Restart Tekla Structures to activate the new value.

5.114 XS_DRAWING_ASSEMBLY_HATCH_SCHEMA

Category

Hatching

Use to indicate the name of the schema file to use for assembly drawings.

Example

To use the default schema file, enter `assembly.htc`.

This advanced option is model specific and the setting is saved in the options database.

5.115 XS_DRAWING_CAST_UNIT_HATCH_SCHEMA

Category

Hatching

Use to determine the name of the schema file used for cast unit drawings.

This advanced option is model specific and the setting is saved in the options database.

Example

To use the default schema file, enter `cast_unit.htc`.

5.116 XS_DRAWING_CHANGE_HIGHLIGHT_COLOR

Category



Drawing Properties





Use to change the highlight color of the automatic change symbols. The color options are RED, DARK RED, ORANGE, DARK YELLOW, GREEN, DARK GREEN, BLUE, DARK BLUE, BLACK, GREY, DARK GREY, CYAN, DARK CYAN and MAGENTA. You can also enter colors as numerical values.

NOTE If you use the default color 190, the symbols are displayed on the screen but they will not appear in the printed drawings.

This advanced option is model specific and the setting is saved in the options database.

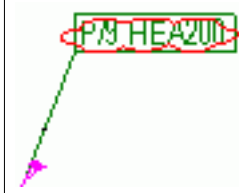
Example

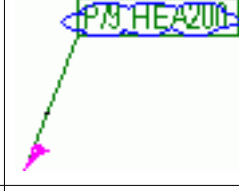
| Set the advanced option to | Color on screen | Color in printed drawings |
|----------------------------|---|---------------------------|
| 190 (default) |  | not visible |
| MAGENTA |  | magenta |

| Set the advanced option to | Color on screen | Color in printed drawings |
|----------------------------|---|---------------------------|
| RED |  | red |
| GREEN |  | green |
| BLUE |  | blue |
| BLACK |  | black |
| GREY |  | grey |

5.117 XS_DRAWING_CLONING_IGNORE_CHECK

Category: Drawing properties

Set to `TRUE` to have Tekla Structures clone a drawing even though all the parts of the original drawing have been deleted and the position number is the same as in the original drawing. The default is `FALSE`.

Note that when `XS_DRAWING_CLONING_IGNORE_CHECK` is set to `TRUE`, Tekla Structures is able to clone a drawing with a selected part that has the same

position number. But if you have selected several parts with the same position number, then only one cloned drawing is created for that position.

This advanced option is model specific and the setting is saved in the options database.

Example

You have drawing A[A.1] in your **Document manager**. You number the model so that the assembly A.1 changes to A.2. In **Document manager**, the A[A.1] drawing is marked with an x and with the status message "All parts deleted." Then you number the model again, so that the assembly in the model changes from A.2 back to A.1. To clone, set the advanced option

`XS_DRAWING_CLONING_IGNORE_CHECK` to `TRUE`, select the A[A.1] drawing (marked with x) from **Document manager** and assembly A.1 from the model, and click **Clone**.

5.118 XS_DRAWING_COMBINE_ADDED_DIMENSIONS

Category

Drawing Properties

Use to control whether added dimensions are merged to existing ones in updated or cloned drawings. If set to `FALSE`, added dimensions are not merged to existing ones. The default value is `TRUE`.

This advanced option is model specific and the setting is saved in the options database.

5.119 XS_DRAWING_CUT_VIEW_COMPARISON_CRITERIA

Category: Drawing views

Use to specify the criteria used when comparing section views. If section views are different, they will be visible and will receive a unique section mark. By default, section views are compared based on the boundaries of the parts (`EXTREMA`) and the orientation of the parts in the view (`ORIENTATION`). The advanced option may contain a combination of the following options separated by a comma:

- `POSITION` compares position numbers of all the parts in the view (including non-dimensioned parts).
- `EXTREMA` compares the boundaries of the parts in the view.
- `ORIENTATION` compares the orientation of the parts in the view.

- `SHOWALL` considers all section views different and displays them with unique section marks.
- `EXACT` uses more rigid rules when comparing section views. Use `EXACT` only in combination with the options `EXTREMA` or `ORIENTATION`.

`EXACT, ORIENTATION` = Part x/y axes need to be the same.

`ORIENTATION` = Part x/y axes need to be the same or opposite.

`EXACT, EXTREMA` = Part extremas need to be the same in any direction.

`EXTREMA` = Part extremas need to be the same in each part's local direction.

If orientation is 90 degrees different, the extremas can still be the same if both parts have the same x and y dimension, for example.

This advanced option is role specific. When the type **SYSTEM(ROLE)** is in use, the default value is used. When the type **MODEL(ROLE)** or **DRAWING(ROLE)** is in use, you can change the value, which is then the same for all users in the current model.

5.120 XS_DRAWING_FILTER_UDAS_WITHOUT_TYPE_CHECK

Category

Drawing Properties

Set this advanced option to `FALSE` (default) to use only user-defined attributes that have been defined for the object in the `object.inp` in drawing view filtering.

This advanced option is model specific and the setting is saved in the options database.

5.121 XS_DRAWING_GA_HATCH_SCHEMA

Category

Hatching

Use to determine the name of the schema file used for general arrangement drawings.

This advanced option is model specific and the setting is saved in the options database.

Example

To use the default schema file, enter `general.htc`.

5.122 XS_DRAWING_GRID_LABEL_FRAME_FIXED_WIDTH

Category: Drawing properties

Use to specify a fixed size for the grid label frames. This is useful, for example, when you want all the grid label frames to be the same size no matter whether there are one or two digits in the frame. If you set this advanced option to zero (0), the width of the grid label frame depends on the width of the grid label. Enter the desired value in millimeters.

A fixed width of 18 is suggested for 5 characters (XX.XX) when the text height is 3/16. Change the fixed width to 14 for 4 characters (XX.X), 12 for 3 characters (X.X), and to 10 for 2 characters (XX). If you use a different text height than 3/16, fixed width values need to be adjusted accordingly. This advanced option overrides the automatic frame width calculation for grid labels.

If you do not set this advanced option, Tekla Structures adjusts the grid label frames to text within each frame.

Example of grid label frames when the frame size is not fixed:

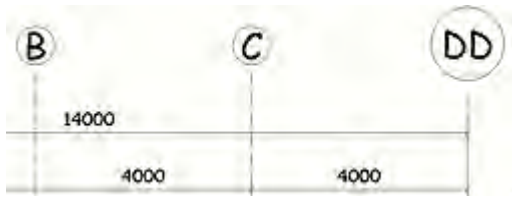

Example of grid label frames when the frame size is fixed:

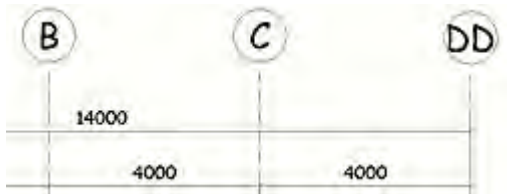

This advanced option is role specific. When the type **SYSTEM(ROLE)** is in use, the default value is used. When the type **MODEL(ROLE)** or **DRAWING(ROLE)** is in use, you can change the value, which is then the same for all users in the current model.

5.123 XS_DRAWING_GRID_LABEL_FRAME_LINE_WIDTH_FACTOR

Category: Drawing Properties

Use to change the thickness of the grid label frame in drawings. You may want to emphasize the grid label frames so that they are shown with a thicker line than the rest of the grid.

Example

`XS_DRAWING_GRID_LABEL_FRAME_LINE_WIDTH_FACTOR=1`

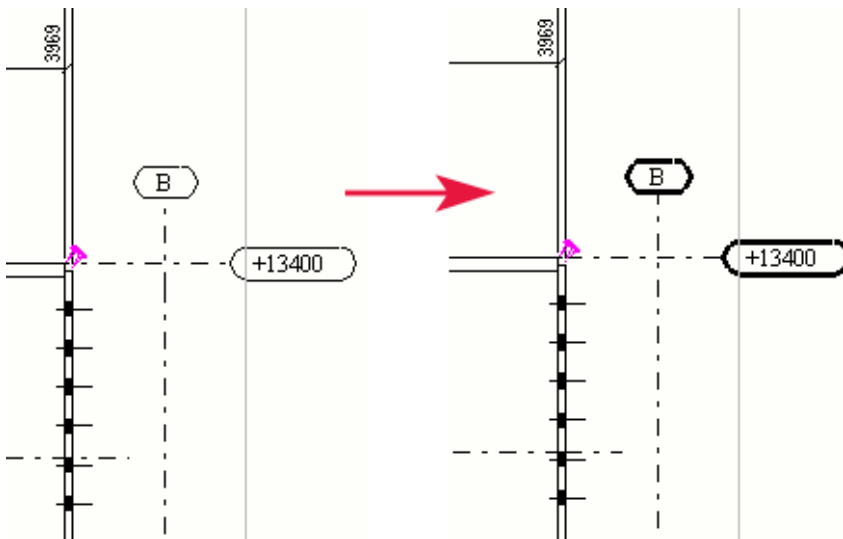

NOTE Each color has a certain line thickness. The thickness of the grid label frame on the printed black-and-white drawings depends on the color that has been defined for the grid label in the grid properties and on the value of this advanced option. .

This advanced option is model specific and the setting is saved in the options database.

5.124 XS_DRAWING_HISTORY_LOG_TYPE

Category

Drawing Properties

Use to define the contents of the drawing history log file `drawing_history.log`. You can use the following options individually or in any combination.

- ALL

- NEW
- DELETED (default)
- MODIFIED

Example

Separate the options using the `_` character, for example, `NEW_DELETED`.

This advanced option is model specific and the setting is saved in the options database.

5.125 XS_DRAWING_IGNORE_ZERO_LEVELS_IN_PART_MARKS

Category: Marking - parts

Use to control whether zero levels (+0.000) are shown or hidden in part marks. By default the advanced option is set to `FALSE`, so zero levels are shown in part marks. Set to `TRUE` to hide the zero levels in part marks.

For example, you can use this advanced option for hiding connection side marks at a specified distance from the view plane.

TIP To list level information in part marks, go to **Part mark properties**, insert the **User-defined attribute** element and enter one of the following template attributes:

- `ASSEMBLY_BOTTOM_LEVEL`
- `ASSEMBLY_TOP_LEVEL`
- `CAST_UNIT_BOTTOM_LEVEL`
- `CAST_UNIT_TOP_LEVEL`

This advanced option is role specific. When the type **SYSTEM(ROLE)** is in use, the default value is used. When the type **MODEL(ROLE)** or **DRAWING(ROLE)** is in use, you can change the value, which is then the same for all users in the current model.

5.126 XS_DRAWING_PART_REFERENCE_LINE_TYPE

Category: Drawing properties

Use to set the reference line type in drawings. You can use the following switches:

- `POINT_LINE` creates a line between the part's creation points.

- DEFINITION_LINE creates a line between the part's definition points (creation points + end offsets).
- CORNER_REFERENCE_LINE creates a line between the part's corner points.

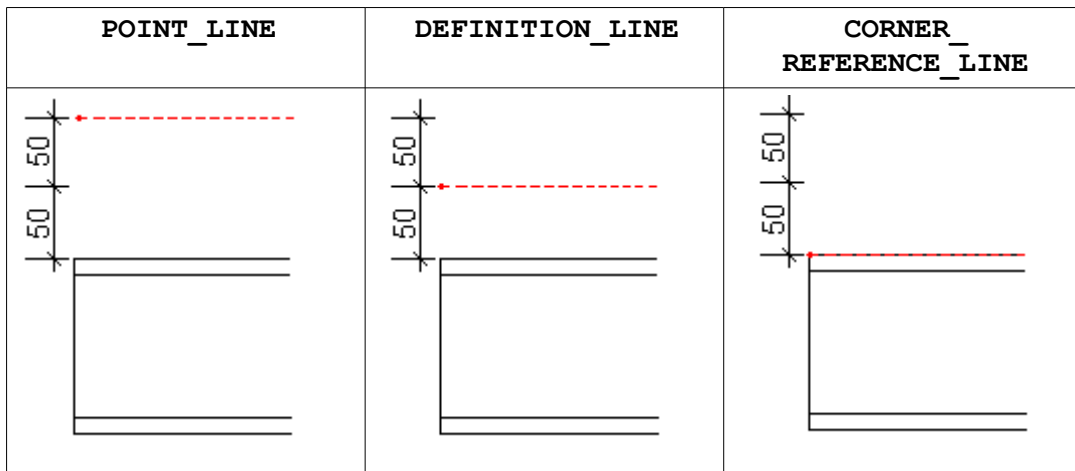

This advanced option is model specific and the setting is saved in the options database.

5.127 XS_DRAWING_PART_SYMBOL_REPRESENTATION_TYPE

Category: Drawing properties

Use this advanced option for adjusting the symbol representation of parts in drawings. The value 0 (default) means by reference line, and the value 1 means by center line. This affects the part representation options **Symbol** and **Symbol with partial profile** in part properties.

This advanced option is model specific and the setting is saved in the options database.

5.128 XS_DRAWING_PLOT_FILE_DIRECTORY

Category Printing

Use this advanced option to define the folder where **Printer Catalog** creates the plot files if the file name field is empty in the **Print Drawings** dialog box. By default, `.\PlotFiles` is used.

Note that **Printer Catalog** is used only when you have set the advanced option `XS_USE_OLD_PLOT_DIALOG` to TRUE in **File menu --> Settings --> Advanced options --> Printing** .

This advanced option also defines the folder where new DWG/DXF drawing export creates dwg/dxf files if the file location field is empty in the **Export drawings to DWG/DXF** dialog box. By default, .\ is used.

NOTE This advanced option overrides the folder defined in the **Printer Catalog** and in the new **Export drawings to DWG/DXF** dialog box.

5.129 XS_DRAWING_PLOT_FILE_NAME

This advanced option must be set in an initialization (.ini) file.

Use this advanced option to define print file names for drawings, if the filename is missing from the **Print Drawings** dialog box. This advanced option is used if you have not entered a value for some of the following advanced options: XS_DRAWING_PLOT_FILE_NAME_A,

XS_DRAWING_PLOT_FILE_NAME_C, XS_DRAWING_PLOT_FILE_NAME_G, XS_DRAWING_PLOT_FILE_NAME_W, or XS_DRAWING_PLOT_FILE_NAME_M.

Enter any combination of text and options:

NAME

NAME.-

NAME.

DRAWING_NAME

DRAWING_NAME.

DRAWING_NAME.-

REVISION

DRAWING_REVISION

REV_MARK

REVISION_MARK

DRAWING_REVISION_MARK

REV

TITLE

DRAWING_TITLE

UDA:<drawing user-defined attribute>, for example,

UDA:DRAWING_USERFIELD_1

TPL:<template attribute>, for example TPL:TITLE1 or TPL:TITLE2

<variable>?- <text>

The question mark (?) can be used for querying if a <variable> is set, and if it does, the <text> after the question mark until the last % will be printed. See the second example below.

This advanced option is model specific and the setting is saved in the options database.

Example

```
%DRAWING_NAME.% - %DRAWING_TITLE%%DRAWING_REVISION? - Rev %  
%REVISION_MARK%
```

If you define %DRAWING_NAME.% - %DRAWING_TITLE%
%DRAWING_REVISION? - Rev %%REVISION_MARK%, a .pdf file with a name
P1 - PLATE - Rev A.pdf will be created from a single part drawing, for
example, where

DRAWING_NAME . = P1, this is the part position without punctuation.

DRAWING_TITLE = PLATE, this is the name that you have entered in the **Name**
box in drawing properties.

DRAWING_REVISION = empty, if there are no revisions, or a numeric value 1, 2,
3, etc according to the revision selected in **Rev.No.** in the **Revision Handling**
dialog box. The actual value is not written in the plot file name, but the text
after the question mark (?).

- Rev is the text to be printed, if DRAWING_REVISION gives a value. If
DRAWING_REVISION does not give a value, the text - Rev will not be printed.
In this case, the plot file name will not have REVISION_MARK either because
the drawing has not been revised.

REVISION_MARK = A, because A has been defined as the revision mark in the
Revision Handling dialog box.

See also

Customize print file names

5.130 XS_DRAWING_PLOT_FILE_NAME_A

Category: Printing

Use to define print file names for assembly drawings.

Enter any combination of text and options:

NAME

NAME . -

NAME .

DRAWING_NAME

DRAWING_NAME.

DRAWING_NAME.-

REVISION

DRAWING_REVISION

REV_MARK

REVISION_MARK

DRAWING_REVISION_MARK

REV

TITLE

DRAWING_TITLE

UDA:<drawing user-defined attribute>, for example,

UDA:DRAWING_USERFIELD_1

TPL:<template attribute>, for example TPL:TITLE1 or TPL:TITLE2

<variable>?- <text>

The question mark (?) can be used for querying if a <variable> is set, and if it does, the <text> after the question mark will be printed. See the second example below.

This advanced option is role specific. When the type **SYSTEM(ROLE)** is in use, the default value is used. When the type **MODEL(ROLE)** or **DRAWING(ROLE)** is in use, you can change the value, which is then the same for all users in the current model.

Example

```
%DRAWING_NAME.% - %DRAWING_TITLE%%DRAWING_REVISION? - Rev %  
%REVISION_MARK%
```

If you define %DRAWING_NAME.% - %DRAWING_TITLE%
%DRAWING_REVISION? - Rev %%REVISION_MARK%, a .pdf file with a name
P1 - PLATE - Rev A.pdf will be created from a single part drawing, for
example, where

DRAWING_NAME. = P1, this is the part position without punctuation.

DRAWING_TITLE = PLATE, this is the name that you have entered in the **Name**
box in drawing properties.

DRAWING_REVISION = empty, if there are no revisions, or a numeric value 1, 2,
3, etc according to the revision selected in **Rev.No.** in the **Revision Handling**
dialog box. The actual value is not written in the plot file name, but the text
after the question mark (?).

- Rev is the text to be printed, if DRAWING_REVISION gives a value. If
DRAWING_REVISION does not give a value, the text - Rev will not be printed.

In this case, the plot file name will not have `REVISION_MARK` either because the drawing has not been revised.

`REVISION_MARK = A`, because A has been defined as the revision mark in the **Revision Handling** dialog box.

See also

Customize print file names

5.131 XS_DRAWING_PLOT_FILE_NAME_W

Category: Printing

Use to define print filenames for single part drawings.

Enter any combination of text and options:

NAME

NAME . -

NAME .

DRAWING_NAME

DRAWING_NAME .

DRAWING_NAME . -

REVISION

DRAWING_REVISION

REV_MARK

REVISION_MARK

DRAWING_REVISION_MARK

REV

TITLE

DRAWING_TITLE

UDA:<drawing user-defined attribute>, for example,

UDA:DRAWING_USERFIELD_1

TPL:<template attribute>, for example TPL:TITLE1 or TPL:TITLE2

<variable>?- <text>

The question mark (?) can be used for querying if a <variable> is set, and if it does, the <text> after the question mark will be printed. See the second example below.

This advanced option is role specific. When the type **SYSTEM(ROLE)** is in use, the default value is used. When the type **MODEL(ROLE)** or **DRAWING(ROLE)** is

in use, you can change the value, which is then the same for all users in the current model.

Examples

```
%DRAWING_NAME.% - %DRAWING_TITLE%%DRAWING_REVISION? - Rev %  
%REVISION_MARK%
```

If you define %DRAWING_NAME.% - %DRAWING_TITLE%
%DRAWING_REVISION? - Rev %%REVISION_MARK%, a .pdf file with a name
P1 - PLATE - Rev A.pdf will be created from a single part drawing, for
example, where

DRAWING_NAME. = P1, this is the part position without punctuation.

DRAWING_TITLE = PLATE, this is the name that you have entered in the **Name**
box in drawing properties.

DRAWING_REVISION = empty, if there are no revisions, or a numeric value 1, 2,
3, etc according to the revision selected in **Rev.No.** in the **Revision Handling**
dialog box. The actual value is not written in the plot file name, but the text
after the question mark (?).

- Rev is the text to be printed, if DRAWING_REVISION gives a value. If
DRAWING_REVISION does not give a value, the text - Rev will not be printed.
In this case, the plot file name will not have REVISION_MARK either because
the drawing has not been revised.

REVISION_MARK = A, because A has been defined as the revision mark in the
Revision Handling dialog box.

See also

Customize print file names

5.132 XS_DRAWING_PLOT_FILE_NAME_G

Category: Printing

Use to define print file names for general arrangement drawings.

Enter any combination of text and options:

NAME

NAME. -

NAME.

DRAWING_NAME

DRAWING_NAME.

DRAWING_NAME. -

REVISION

DRAWING_REVISION

REV_MARK

REVISION_MARK

DRAWING_REVISION_MARK

REV

TITLE

DRAWING_TITLE

UDA:<drawing user-defined attribute>, for example,

UDA:DRAWING_USERFIELD_1

TPL:<template attribute>, for example TPL:TITLE1 or TPL:TITLE2

<variable>?- <text>

The question mark (?) can be used for querying if a <variable> is set, and if it does, the <text> after the question mark will be printed. See the second example below.

This advanced option is role specific. When the type **SYSTEM(ROLE)** is in use, the default value is used. When the type **MODEL(ROLE)** or **DRAWING(ROLE)** is in use, you can change the value, which is then the same for all users in the current model.

Example

```
%DRAWING_NAME.% - %DRAWING_TITLE%%DRAWING_REVISION? - Rev %  
%REVISION_MARK%
```

If you define %DRAWING_NAME.% - %DRAWING_TITLE%

%DRAWING_REVISION? - Rev %%REVISION_MARK%, a .pdf file with a name P1 - PLATE - Rev A.pdf will be created from a single part drawing, for example, where

DRAWING_NAME . = P1, this is the part position without punctuation.

DRAWING_TITLE = PLATE, this is the name that you have entered in the **Name** box in drawing properties.

DRAWING_REVISION = empty, if there are no revisions, or a numeric value 1, 2, 3, etc according to the revision selected in **Rev.No.** in the **Revision Handling** dialog box. The actual value is not written in the plot file name, but the text after the question mark (?).

- Rev is the text to be printed, if DRAWING_REVISION gives a value. If DRAWING_REVISION does not give a value, the text - Rev will not be printed. In this case, the plot file name will not have REVISION_MARK either because the drawing has not been revised.

REVISION_MARK = A, because A has been defined as the revision mark in the **Revision Handling** dialog box.

See also

Customize print file names

5.133 XS_DRAWING_PLOT_FILE_NAME_M

Category: Printing

Use to define print file names for multidrawings.

Enter any combination of text and options:

NAME

NAME.-

NAME.

DRAWING_NAME

DRAWING_NAME.

DRAWING_NAME.-

REVISION

DRAWING_REVISION

REV_MARK

REVISION_MARK

DRAWING_REVISION_MARK

REV

TITLE

DRAWING_TITLE

UDA:<drawing user-defined attribute>, for example,

UDA:DRAWING_USERFIELD_1

TPL:<template attribute>, for example TPL:TITLE1 or TPL:TITLE2

<variable>?- <text>

The question mark (?) can be used for querying if a <variable> is set, and if it does, the <text> after the question mark will be printed. See the second example below.

This advanced option is role specific. When the type **SYSTEM(ROLE)** is in use, the default value is used. When the type **MODEL(ROLE)** or **DRAWING(ROLE)** is in use, you can change the value, which is then the same for all users in the current model.

Example

`%DRAWING_NAME.% - %DRAWING_TITLE%%DRAWING_REVISION? - Rev %
%REVISION_MARK%`

If you define `%DRAWING_NAME.% - %DRAWING_TITLE%`
`%DRAWING_REVISION? - Rev %%REVISION_MARK%`, a .pdf file with a name
P1 - PLATE - Rev A.pdf will be created from a single part drawing, for
example, where

`DRAWING_NAME.` = P1, this is the part position without punctuation.

`DRAWING_TITLE` = PLATE, this is the name that you have entered in the **Name**
box in drawing properties.

`DRAWING_REVISION` = empty, if there are no revisions, or a numeric value 1, 2,
3, etc according to the revision selected in **Rev.No.** in the **Revision Handling**
dialog box. The actual value is not written in the plot file name, but the text
after the question mark (?).

- Rev is the text to be printed, if `DRAWING_REVISION` gives a value. If
`DRAWING_REVISION` does not give a value, the text - Rev will not be printed.
In this case, the plot file name will not have `REVISION_MARK` either because
the drawing has not been revised.

`REVISION_MARK` = A, because A has been defined as the revision mark in the
Revision Handling dialog box.

See also

Customize print file names

5.134 XS_DRAWING_PLOT_FILE_NAME_C

Category: Printing

Use to define print file names for cast unit drawings.

Enter any combination of text and options:

NAME

NAME . -

NAME .

DRAWING_NAME

DRAWING_NAME .

DRAWING_NAME . -

REVISION

DRAWING_REVISION

REV_MARK

REVISION_MARK

DRAWING_REVISION_MARK

REV

TITLE

DRAWING_TITLE

UDA:<drawing user-defined attribute>, for example,

UDA:DRAWING_USERFIELD_1

TPL:<template attribute>, for example TPL:TITLE1 or TPL:TITLE2

<variable>?- <text>

The question mark (?) can be used for querying if a <variable> is set, and if it does, the <text> after the question mark will be printed. See the second example below.

This advanced option is role specific. When the type **SYSTEM(ROLE)** is in use, the default value is used. When the type **MODEL(ROLE)** or **DRAWING(ROLE)** is in use, you can change the value, which is then the same for all users in the current model.

Example

```
%DRAWING_NAME.% - %DRAWING_TITLE%%DRAWING_REVISION? - Rev %  
%REVISION_MARK%
```

If you define %DRAWING_NAME.% - %DRAWING_TITLE%
%DRAWING_REVISION? - Rev %%REVISION_MARK%, a .pdf file with a name
P1 - PLATE - Rev A.pdf will be created from a single part drawing, for
example, where

DRAWING_NAME . = P1, this is the part position without punctuation.

DRAWING_TITLE = PLATE, this is the name that you have entered in the **Name**
box in drawing properties.

DRAWING_REVISION = empty, if there are no revisions, or a numeric value 1, 2,
3, etc according to the revision selected in **Rev.No.** in the **Revision Handling**
dialog box. The actual value is not written in the plot file name, but the text
after the question mark (?).

- Rev is the text to be printed, if DRAWING_REVISION gives a value. If
DRAWING_REVISION does not give a value, the text - Rev will not be printed.
In this case, the plot file name will not have REVISION_MARK either because
the drawing has not been revised.

REVISION_MARK = A, because A has been defined as the revision mark in the
Revision Handling dialog box.

See also

Customize print file names

5.135 XS_DRAWING_POINT_SCALE

Category

Drawing Properties

Use to scale the points Tekla Structures uses to create reference lines. Enter the scale as a decimal. The default value is 0.5.

This advanced option is model specific and the setting is saved in the options database.

5.136 XS_DRAWING_RENDERING_ENGINE

Category: Drawing views

Set this advanced option to `FOG` to activate the FOG rendering engine. When set to `FOG`, the overall rendering is faster, which can be seen when you pan or zoom, for example.

To use the Windows Graphics Device Interface (GDI) rendering, set this advanced option to `GDI`. `GDI` is the default value.

Note that setting the [XS_USE_SMART_PAN \(page 493\)](#) advanced option to `TRUE` is useful for the Windows GDI only and has no effect on FOG rendering.

This advanced option is user specific and the setting is saved in `options.bin` under the user folder, for example, in `C:\Users\<user>\AppData\Local\Trimble\Tekla Structures\<version>\UserSettings`.

5.137 XS_DRAWING_SCALE_SEPARATOR_CHAR

Category: Drawing properties

Defines the separator character used in drawing scales. The default character is colon (:).

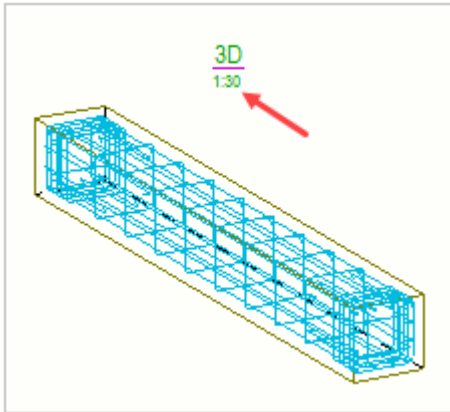

This advanced option is model specific and the setting is saved in the options database.

5.138 XS_DRAWING_SHEET_HEIGHT

Category

Drawing View

Use to define the default height of a drawing sheet. The default value is 800.

This advanced option is user specific and the setting is saved in `options.bin` under the user folder, for example, in `C:\Users\\AppData\Local\Trimble\Tekla Structures\\UserSettings`. Restart Tekla Structures to activate the new value.

See also

[XS_DRAWING_SHEET_POSITION_X](#) (page 193)

5.139 XS_DRAWING_SHEET_POSITION_X

Category

Drawing View

Use to define the initial position of the drawing sheet. This is useful when using a dual display. The default value is 0.

You can set this in the following ways:

```
XS_DRAWING_SHEET_POSITION_X=50XS_DRAWING_SHEET_POSITION_Y=50XS_DRAWING_SHEET_HEIGHT=600XS_DRAWING_SHEET_WIDTH=900
```

X and Y are the coordinates of the upper left corner of the drawing view, measured from the upper left corner of the MDI client window (the dark gray area in the Tekla Structures window).

This advanced option is user specific and the setting is saved in `options.bin` under the user folder, for example, in `C:\Users\\AppData\Local\Trimble\Tekla Structures\\UserSettings`. Restart Tekla Structures to activate the new value.

See also

[XS_DRAWING_SHEET_POSITION_Y \(page 194\)](#)

[XS_DRAWING_SHEET_HEIGHT \(page 193\)](#)

[XS_DRAWING_SHEET_WIDTH \(page 195\)](#)

5.140 XS_DRAWING_SHEET_POSITION_Y

Category

Drawing View

Use to define the initial position of the drawing sheet. This is useful when using a dual display. The default value is 0.

You can set this in the following ways:

```
XS_DRAWING_SHEET_POSITION_X=50 XS_DRAWING_SHEET_POSITION_Y=50  
XS_DRAWING_SHEET_HEIGHT=600 XS_DRAWING_SHEET_WIDTH=900
```

X and Y are the coordinates of the upper left corner of the drawing view, measured from the upper left corner of the MDI client window (the dark gray area in the Tekla Structures window).

This advanced option is user specific and the setting is saved in `options.bin` under the user folder, for example, in `C:\Users\\AppData\Local\Trimble\Tekla Structures\\UserSettings`. Restart Tekla Structures to activate the new value.

See also

[XS_DRAWING_SHEET_POSITION_X \(page 193\)](#)

[XS_DRAWING_SHEET_HEIGHT \(page 193\)](#)

[XS_DRAWING_SHEET_WIDTH \(page 195\)](#)

5.141 XS_DRAWING_SHEET_WIDTH

Category

Drawing view

Use to define the default width of a drawing sheet. The default value is 1000.

This advanced option is user specific and the setting is saved in `options.bin` under the user folder, for example, in `C:\Users\\AppData\Local\Trimble\Tekla Structures\\UserSettings`. Restart Tekla Structures to activate the new value.

See also

[XS_DRAWING_SHEET_POSITION_X](#) (page 193)

[XS_DRAWING_SHEET_POSITION_Y](#) (page 194)

[XS_DRAWING_SHEET_HEIGHT](#) (page 193)

5.142 XS_DRAWING_SINGLE_PART_HATCH_SCHEMA

Category

Hatching

Use to determine the name of the schema file used for single part drawings.

This advanced option is model specific and the setting is saved in the options database.

Example

To use the default schema file, enter `single.htc`.

5.143 XS_DRAWING_SNAPSHOT_CREATION

Category

Drawing Properties

If you set the this advanced option to `FALSE`, the snapshots are not created automatically when you save a drawing. The default value is `TRUE`, which means that snapshots are created automatically when you save a drawing.

This advanced option is model specific and the setting is saved in the options database.

5.144 XS_DRAWING_SOLID_MERGE_TOLERANCE

Category

Drawing View

Use to define the limit that determines whether some objects in a cast unit are merged in the drawing view. Enter the value in millimeters. The default value is 6.0.

This advanced option is role specific. When the type **SYSTEM(ROLE)** is in use, the default value is used. When the type **MODEL(ROLE)** or **DRAWING(ROLE)** is in use, you can change the value, which is then the same for all users in the current model.

Example

The following example shows the result of merging parts.

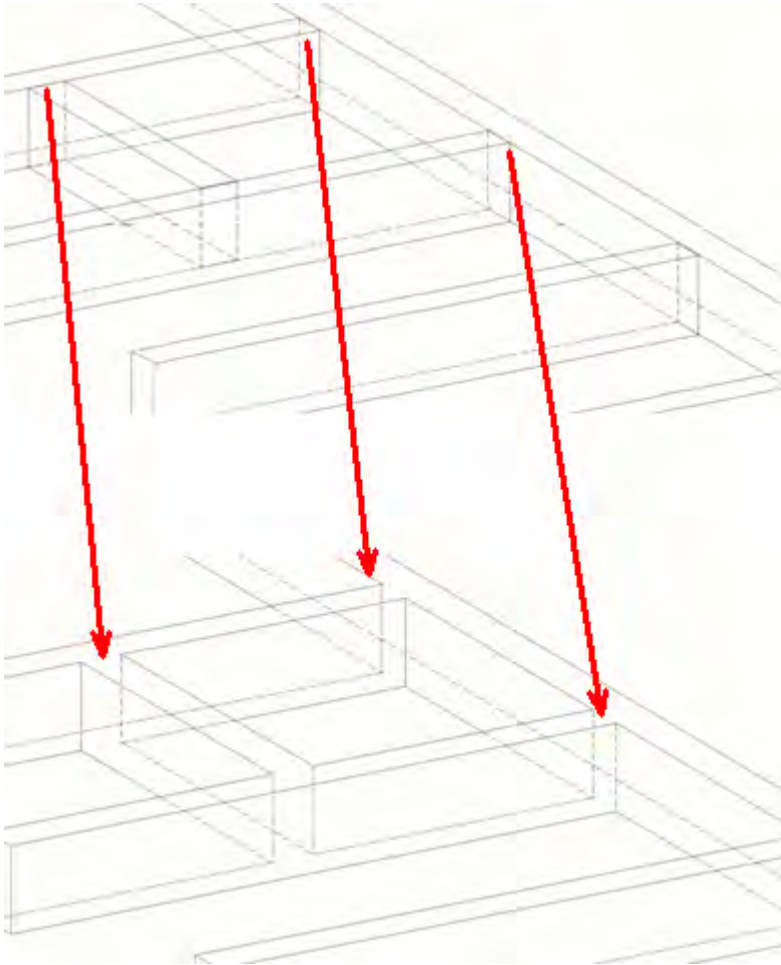

In the following example, unnecessary segments of curved parts that are one above another are removed.

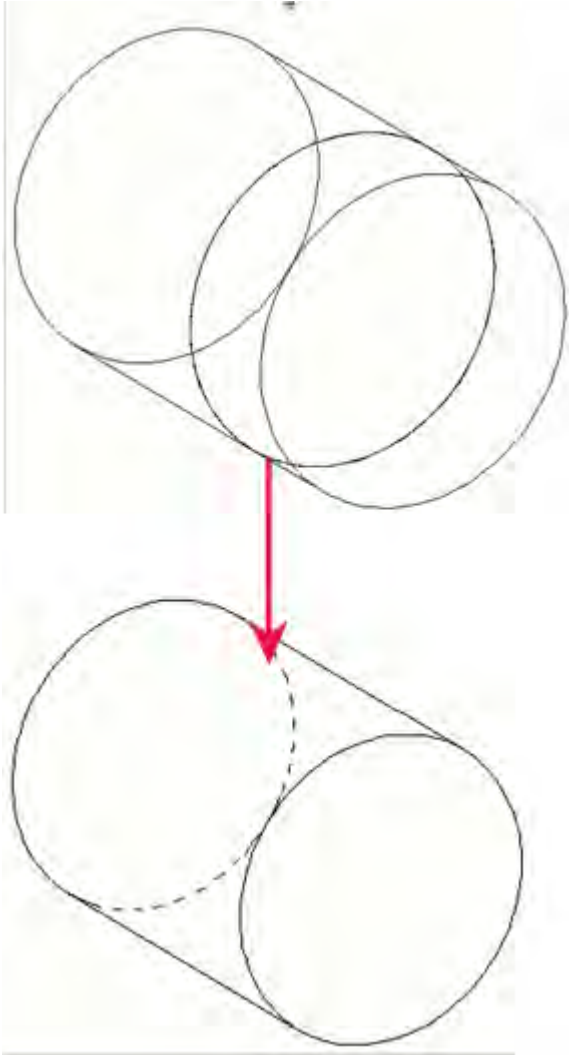

5.145 XS_DRAWING_STUD_REPRESENTATION

Category

Drawing Properties

Use this advanced option to define different representation options for bolts and studs.

Set the advanced option to `SOLID` (default) to have the studs drawn as solid objects regardless of the bolt representation setting, and to `AS_BOLT` to have the studs drawn according to the settings in the **Bolt properties** dialog box.

This advanced option is role-specific. When you change the value, it changes from system- to model-specific, and its value is the same for all users in the current model.

5.146 XS_DRAWING_TEMPLATES_LIBRARY

Category: Drawing properties

You define the location of the drawing template library by setting this advanced option to point to the model folder that contains the template drawings.

This advanced option is model specific and the setting is saved in the options database. .

Example

```
C:\TeklaStructuresModels\CloningTemplate
```

(where CloningTemplate is the model name).

To use the a cloning template library and the cloning template:

1. Open the `user.ini` file located in the folder `..\Users\<user>\AppData\Local\Trimble\Tekla Structures\<version>\UserSettings` in a text editor.
2. Set the advanced option `XS_DRAWING_TEMPLATES_LIBRARY` to point to the model folder that contains the cloning templates (template library):

```
set XS_DRAWING_TEMPLATES_LIBRARY=%XS_RUNPATH%\DrawingLibrary
```

For example:

```
set XS_DRAWING_TEMPLATES_LIBRARY=C:\TeklaStructuresModels\CloningTemplate
```

(where CloningTemplate is the model name).

3. To open the **Clone Drawing** dialog box, click **Clone** in **Document manager**.
4. Use the **Objects and actions in cloning** options to define the drawing objects to be cloned and the actions for each cloned object.
5. Select the **Clone from > Other model** option. You can see that the CloningTemplate folder is displayed in the box.
6. Click the **Select template...** button.
7. In the **Drawing Templates** dialog box, select the cloning template.
8. Leave the list open and clone the drawing by clicking **Clone selected**.

5.147 XS_DRAWING_UDAS_MODIFY_ALL_DRAWING_TYPES

Category: Drawing Properties

Use to modify the user-defined attributes of all selected drawings in **Document manager** at the same time, even if the drawings are of different types.

- To allow the modification of user-defined attributes for all drawings types at the same time, set the advanced option to `TRUE`. `TRUE` is the default value.
- To allow the modification of user-defined attributes only for one drawing type at a time, set the advanced option to `FALSE`.

This advanced option is user specific and the setting is saved in `options.bin` under the user folder, for example, in `C:\Users\\AppData\Local\Trimble\Tekla Structures\\UserSettings`. Restart Tekla Structures to activate the new value.

5.148 XS_DRAWING_UPDATE_VIEW_PLACING

Category

Drawing Properties

Use to control how the view placing works. If the views do not fit on the screen after scaling, Tekla Structures increases the sheet size using the layout properties if autosizing is enabled (**Layout** --> **Drawing size** --> **Size definition mode** --> **Autosize**). Use this advanced option together with [XS_INTELLIGENT_DRAWING_ALLOWED](#) (page 270).

This advanced option is model specific and the setting is saved in the options database.

| Value | Description |
|---------------------------------|--|
| <code>TRUE</code> | Updates the view placing. Does not affect the scale or the sheet size. |
| <code>TRUE, SCALE</code> | Updates the view placing and scales the view if the view does not fit on the sheet. Tekla Structures scales the views smaller using the scales in layout properties. |
| <code>TRUE, SHEET</code> | Updates the view and increases the sheet size if the view does not fit on the sheet. |
| <code>TRUE, SHEET, SCALE</code> | Updates the view, scales the view and increases the sheet size, if necessary. |
| <code>TRUE, CLONING_ONLY</code> | Updates the view placing. Does not affect the scale or the sheet size. View placing is updated only during |

| Value | Description |
|---|--|
| | cloning, not during update. <code>CLONING_ONLY</code> is the default value. |
| <code>TRUE, SCALE, CLONING_ONLY</code> | Updates the view placing and scales the view if the view does not fit on the sheet. Tekla Structures scales the views smaller using the scales in layout properties. View placing is updated only during cloning, not during update. |
| <code>TRUE, SHEET, CLONING_ONLY</code> | Updates the view placing and increases the sheet size if the view does not fit on the sheet. View placing is updated only during cloning, not during update. |
| <code>TRUE, SHEET, SCALE, CLONING_ONLY</code> | Updates the view placing, scales the view and increases the sheet size, if necessary. View placing is updated only during cloning, not during update. |
| <code>FALSE</code> | Does not update the view placing or change the view scale or sheet size. |

5.149 XS_DRAWING_USE_WORKSHOP_FORM_FOR_DOUBLE_PARTS_IN_SINGLE_PART_DRAWINGS

Category

Drawing Properties

Set this advanced option to `TRUE` to show haunch profiles always in workshop form as double parts in single part drawings. `TRUE` is the default value. To show the haunch profiles using the part representation selected in the part properties dialog box, set this advanced option to `FALSE`. This setting affects only part representation, not dimensioning or other part properties.

By default, a haunch (translations checked in `drawing.ail`) has different length calculations and uses different part presentation in drawings than a beam. The calculation routine checks the part name, and when the name "HAUNCH" or translations of it is found, the haunch calculation is used.

You can add additional names for haunch profiles in `drawing.ail` file under the `\messages` folder. Use the strings like `drawing_haunch_2` or `drawing_haunch_3`.

Below is an example of the workshop form representation.

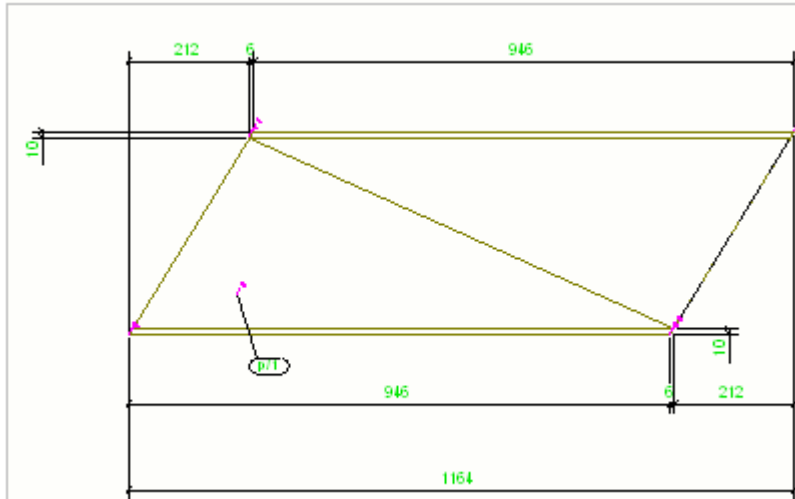

Below is an example of the outline representation.

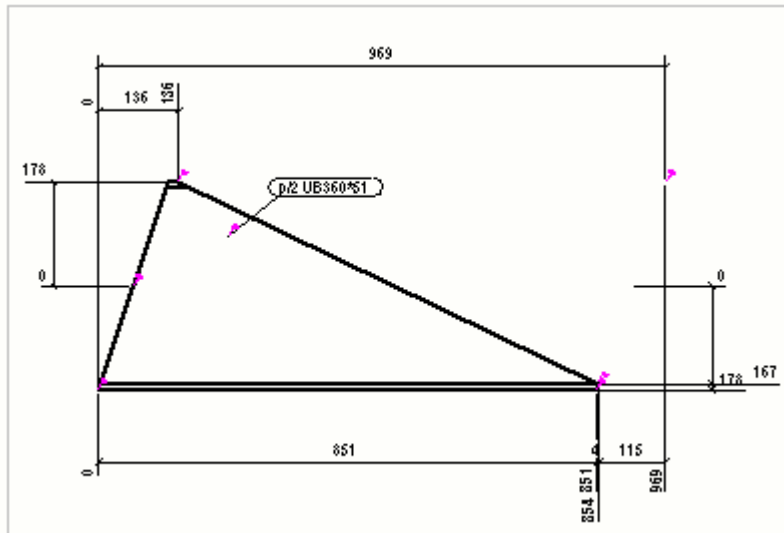

This advanced option is model specific and the setting is saved in the options database.

5.150 XS_DRAWING_VIEW_DIRECTION_MARK_SYMBOL_FRONT

Category

Drawing properties

Use the following advanced options to define the arrow symbol used in section and end view direction marks, for each basic view type (front, top, back, bottom):

- XS_DRAWING_VIEW_DIRECTION_MARK_SYMBOL_FRONT
- XS_DRAWING_VIEW_DIRECTION_MARK_SYMBOL_TOP
- XS_DRAWING_VIEW_DIRECTION_MARK_SYMBOL_BACK
- XS_DRAWING_VIEW_DIRECTION_MARK_SYMBOL_BOTTOM

By default Tekla Structures uses the symbol no 66  in the `xsteel.sym` file (located usually in the folder `\environments\common\symbols\`).

This advanced option is user specific and the setting is saved in `options.bin` under the user folder, for example, in `C:\Users\<user>\AppData\Local\Trimble\Tekla Structures\<version>\UserSettings`. Restart Tekla Structures to activate the new value.

5.151 XS_DRAWING_VIEW_DIRECTION_MARK_SYMBOL_TOP

Category: Drawing properties

Use the following advanced options to define the arrow symbol used in section and end view direction marks, for each basic view type (front, top, back, bottom):

- XS_DRAWING_VIEW_DIRECTION_MARK_SYMBOL_FRONT
- XS_DRAWING_VIEW_DIRECTION_MARK_SYMBOL_TOP
- XS_DRAWING_VIEW_DIRECTION_MARK_SYMBOL_BACK
- XS_DRAWING_VIEW_DIRECTION_MARK_SYMBOL_BOTTOM

By default Tekla Structures uses the symbol no 66  in the `xsteel.sym` file (located usually in the folder `\environments\common\symbols\`).

This advanced option is user specific and the setting is saved in `options.bin` under the user folder, for example, in `C:\Users\<user>\AppData\Local\Trimble\Tekla Structures\<version>\UserSettings`. Restart Tekla Structures to activate the new value.

5.152 XS_DRAWING_VIEW_DIRECTION_MARK_SYMBOL_BACK

Category: Drawing properties

Use the following advanced options to define the arrow symbol used in section and end view direction marks, for each basic view type (front, top, back, bottom):

- XS_DRAWING_VIEW_DIRECTION_MARK_SYMBOL_FRONT
- XS_DRAWING_VIEW_DIRECTION_MARK_SYMBOL_TOP
- XS_DRAWING_VIEW_DIRECTION_MARK_SYMBOL_BACK
- XS_DRAWING_VIEW_DIRECTION_MARK_SYMBOL_BOTTOM

By default Tekla Structures uses the symbol no 66  in the `xsteel.sym` file (located usually in the folder `\environments\common\symbols\`).

This advanced option is user specific and the setting is saved in `options.bin` under the user folder, for example, in `C:\Users\\AppData\Local\Trimble\Tekla Structures\\UserSettings`. Restart Tekla Structures to activate the new value.

5.153 XS_DRAWING_VIEW_DIRECTION_MARK_SYMBOL_BOTTOM

Category: Drawing properties

Use the following advanced options to define the arrow symbol used in section and end view direction marks, for each basic view type (front, top, back, bottom):

- XS_DRAWING_VIEW_DIRECTION_MARK_SYMBOL_FRONT
- XS_DRAWING_VIEW_DIRECTION_MARK_SYMBOL_TOP
- XS_DRAWING_VIEW_DIRECTION_MARK_SYMBOL_BACK
- XS_DRAWING_VIEW_DIRECTION_MARK_SYMBOL_BOTTOM

By default Tekla Structures uses the symbol no 66  in the `xsteel.sym` file (located usually in the folder `\environments\common\symbols\`).

This advanced option is user specific and the setting is saved in `options.bin` under the user folder, for example, in `C:\Users\\AppData\Local\Trimble\Tekla Structures\\UserSettings`. Restart Tekla Structures to activate the new value.

5.154 XS_DRAWING_VIEW_REFERENCE_SYMBOL

Category

Drawing Properties

Use to define the symbol that is displayed in drawing views, when you have selected the option **Custom** in the **Symbol** list in the **Detail** or **Section Symbol Properties** dialog box, or in the view properties dialog boxes of other drawing views. For example, if you enter `xsteel@3`, Tekla Structures uses the symbol number 3 in symbol file `xsteel.sym`.

This advanced option is model specific and the setting is saved in the options database.

5.155 XS_DRIVER

Category: File Locations

The print device definitions you create in the **Printer Catalog (File menu --> Printing --> Printer catalog)** are located in the `plotdev.bin` file. This file is located in the system folder defined for the advanced option `XS_SYSTEM`.

The definitions in the system folder are accessible to all users. You can also save printer definitions in the current model folder or in the project and firm folders, and in a folder indicated by this advanced option. Tekla Structures searches first for `plotdev.bin` in the model, project and firm folders, then in the folder indicated by the advanced option `XS_DRIVER`.

This advanced option is system specific and is read from environment files. Generally, there is no need to modify system-specific settings. Do not modify them if you are not an administrator.

5.156 XS_DSTV_CREATE_AK_BLOCK_FOR_ALL_PLATES

Category: CNC

Set to `TRUE` (default) to create AK blocks in DSTV files also for rectangular plates, combined NC files and part lists.

When you set the advanced option to `FALSE`, Tekla Structures checks whether an AK block needs to be created for the plate, and creates the AK block when needed.

The DSTV standard does not require the creation of AK blocks if the part is completely described by its length, its dimensions and its skewed cuts in the header data. This advanced option allows you to create AK blocks for plates even if the header data already covers all the information of the plate.

This advanced option is model specific and the setting is saved in the options database.

5.157 XS_DSTV_CREATE_AK_BLOCK_FOR_ALL_PROFILES

Category

CNC

When you set the advanced option to `TRUE`, Tekla Structures creates AK blocks in DSTV files for all profiles, combined NC files and part lists. The default value is `TRUE`.

When you set the advanced option to `FALSE`, Tekla Structures checks whether an AK block needs to be created for the part, and creates the AK block when needed.

The DSTV standard does not require the creation of AK blocks if the profile is completely described by its length, its dimensions and its skewed cuts in the header data. This advanced option allows you to create AK blocks for profiles even if the header data already covers all the information of the profile.

This advanced option is model specific and the setting is saved in the options database.

5.158 XS_DSTV_CREATE_NOTCH_ONLY_ON_BEAM_CORNERS

Category: CNC

Use this advanced option to control the rounding of notch corners. The default is `FALSE`.

This advanced option is model specific and the setting is saved in the options database.

Examples

The following example describes the concepts of notches, notch corners, notch corner roundings, and beam corners:

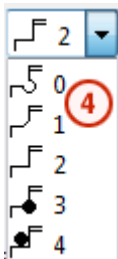
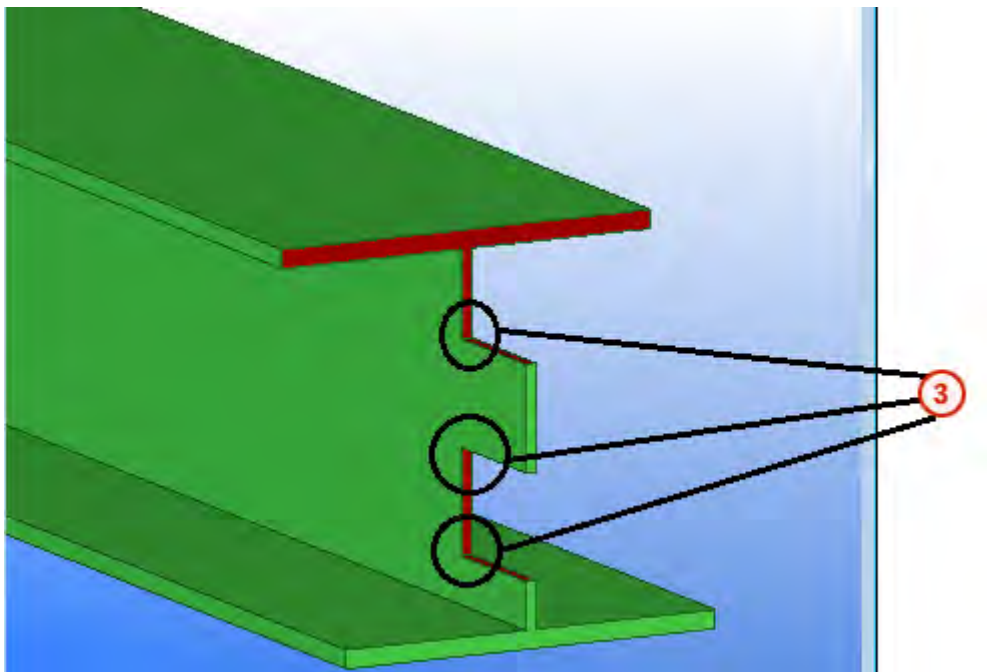
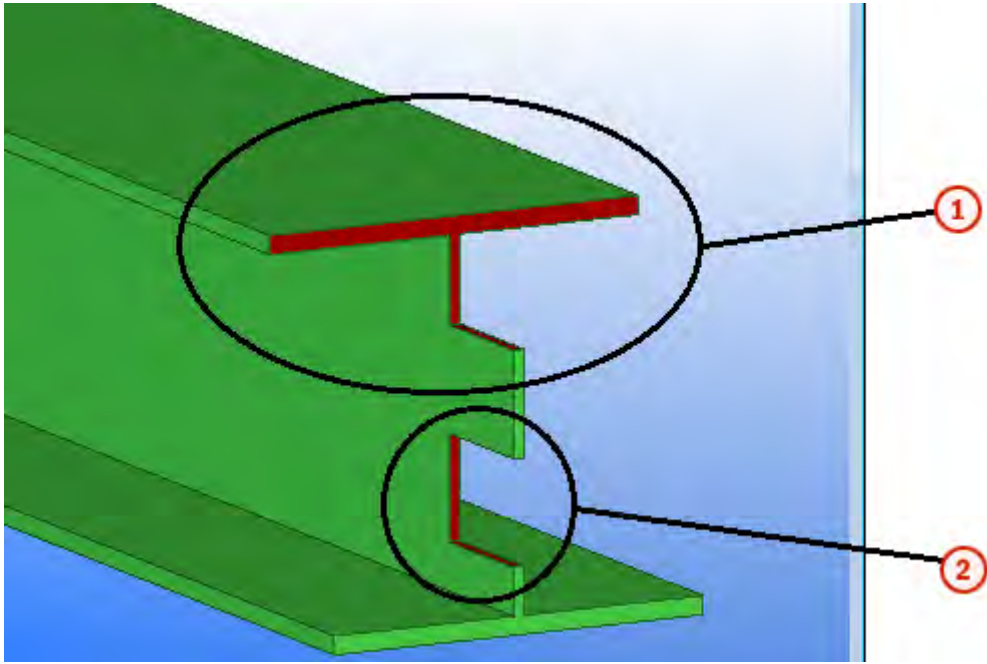

1. The notch is at the beam corner

2. The notch is not at the beam corner
3. Three notches, other corners are ordinary corners
4. Notch corner inner shape (or notch corner rounding) options in the **NC File Settings** dialog box

The table below shows how the

`XS_DSTV_CREATE_NOTCH_ONLY_ON_BEAM_CORNERS` setting (TRUE/FALSE) and the **Inner corners shape** setting affect the NC file.

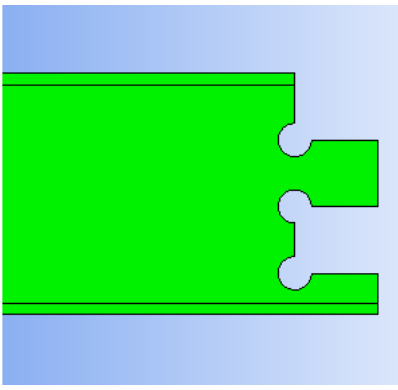
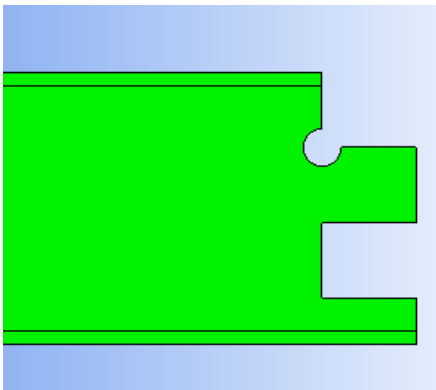
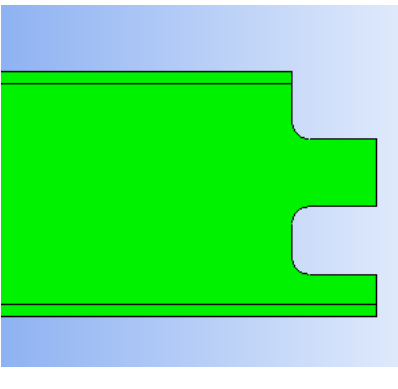
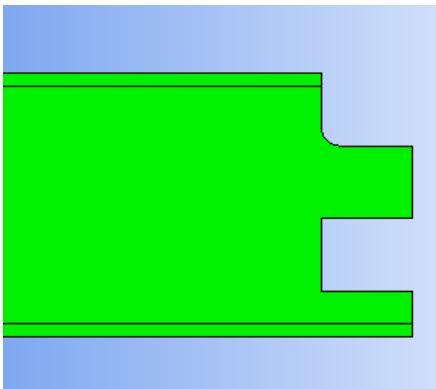
| | <code>XS_DSTV_CREATE_NOTCH_ONLY_ON_BEAM_CORNERS</code> set to FALSE | <code>XS_DSTV_CREATE_NOTCH_ONLY_ON_BEAM_CORNERS</code> set to TRUE |
|--------------------------------|---|--|
| Inner corners shape = 0 |  |  |
| Inner corners shape = 1 |  |  |

5.159 `XS_DSTV_DO_NOT_UNFOLD_POLYBEAM_PLATES`

Category: CNC

Set this advanced option to `TRUE` if you do not want to unfold polybeam plates when you create DSTV files. This means that the polybeam plates will be handled as “cut into shape” instead of “bent into shape” regardless of the

modeling method. For this advanced option to work, the polybeam plate must lie in XY plane of the material.

If you set this advanced option to `FALSE`, Tekla Structures writes the unfolded geometry of the polybeam plates to the DSTV files. The default value is `FALSE`.

In the image below, the polybeam plate on the right lies in XY plane, and setting this advanced option to `TRUE` works. The polybeam plate on the left does not lie in XY plane and the unfolded geometry is written to the DSTV files even if this advanced option is set to `TRUE`.

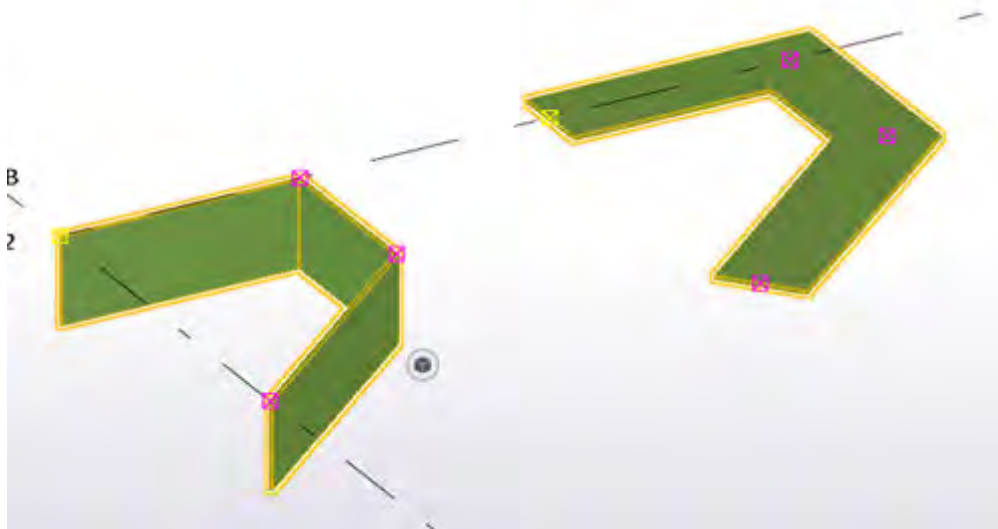

This advanced option is model specific and the setting is saved in the options database.

5.160 XS_DSTV_LIST_NET_WEIGHT

Category: CNC

When you set `XS_DSTV_LIST_NET_WEIGHT` to `TRUE`, net weight is used in MIS list export. If you set it to `FALSE`, gross weight is used. `FALSE` is the default value.

This advanced option is model specific and the setting is saved in the options database.

5.161 XS_DSTV_LIST_SEPARATOR

Category

CNC

Use to define the separator used in DSTV lists. By default the separator is the # character.

This advanced option is model specific and the setting is saved in the options database.

5.162 XS_DSTV_NET_LENGTH

Category

CNC

Set this advanced option to `TRUE` to make cuts affect the part length in the NC file header. Set this advanced option to `FALSE` to make only fittings affect the length.

Using this advanced option also affects MIS values, such as KISS and EJE.

This advanced option is model specific and the setting is saved in the options database.

For advanced users

The AK block of the NC file always contains the correct net length. Using this advanced option writes the net length, instead of the length, to the header block. Some NC machines take the length information either from the header or AK-block. Check with the workshop if you are uncertain which method to use.

NOTE Using this advanced option may damage cutting machines if the part contains cuts and fittings and the longest length is not at the edge of the part (machine tries to start cutting in the middle of the part):



See also

[XS_DSTV_PRINT_NET_AND_GROSS_LENGTH \(page 212\)](#)

5.163 XS_DSTV_NO_SAWING_ANGLES_FOR_PLATES_NEEDED

Category

CNC

With this variable you can define whether you need to specify skew angles in NC file header or not for plates. `TRUE` does not write the skew angles in the file heading. If you want to specify skew angles, set this advanced option to `FALSE`. The default value is `TRUE`.

This advanced option is model specific and the setting is saved in the options database.

See below for an example:

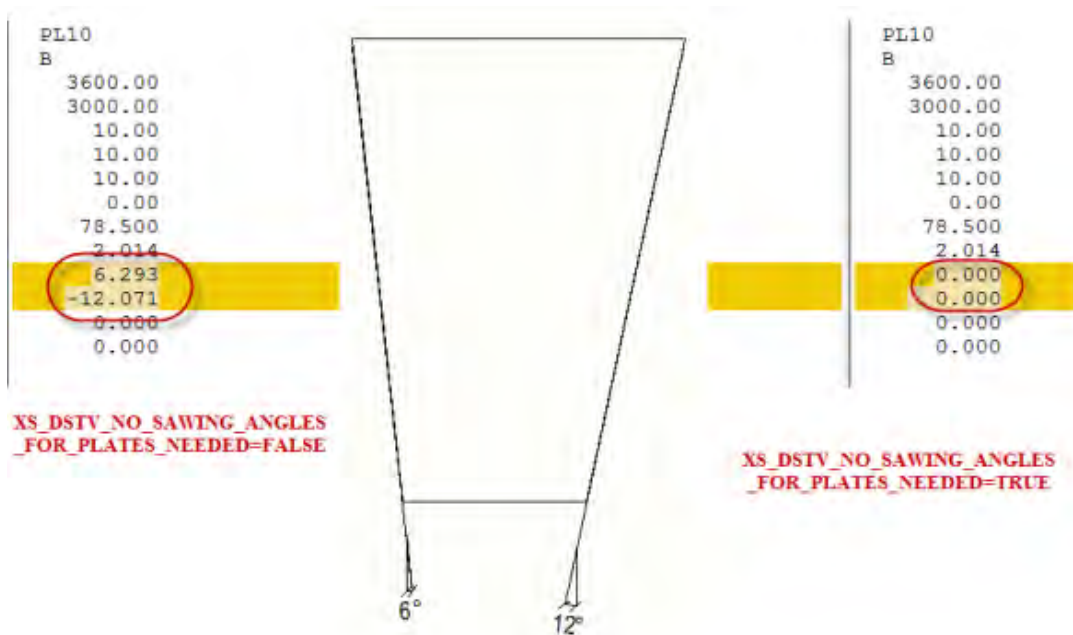

5.164 XS_DSTV_NUMBER_OF_PARTS_BY_SELECTION

Category

CNC

Use to add the number of parts in the header of an NC file by the parts that have been selected in the model.

When you set this advanced option to `TRUE`, and select the **Create for selected parts** option in the **NC Files** dialog box, the number of parts in the header of the NC file matches the number of selected parts.

The default value is `FALSE`.

This advanced option is model specific and the setting is saved in the options database.

5.165 XS_DSTV_PLATE_PROFILE_WITH_WIDTH

Category

CNC

Set this advanced option to `TRUE` to have both the plate thickness and the plate profile width written in the DSTV file header. Set this advanced option to `FALSE` to have only the plate thickness written in the DSTV file header. The default value is `FALSE`.

This advanced option is model specific and the setting is saved in the options database.

5.166 XS_DSTV_PRINT_NET_AND_GROSS_LENGTH

Category

CNC

Set this advanced option to `TRUE` to insert two length values in NC DSTV files:

- Gross length
- Net length

If you do not want to do this, set this advanced option to `FALSE`. `FALSE` is the default value.



① Gross length

② Net length

This advanced option is model specific and the setting is saved in the options database.

NOTE Net and gross length may switch places in the NC file if the advanced option `XS_CHECK_FLAT_LENGTH_ALSO` is set. Then Tekla Structures may use the length value it finds in the `fltprops.inp` file instead.

See also

[XS_DSTV_NET_LENGTH](#) (page 210)

Fittings and line cuts in NC files

[XS_CHECK_FLAT_LENGTH_ALSO](#) (page 91)

5.167 XS_DSTV_REAL_WIDTH_INTO_HEADER_PROFILE_FOR_PLATES

Category: CNC

Set to `TRUE` to have the real plate width instead of the nominal plate width in the header information of DSTV files. The default is `FALSE`.

Here is an example of the difference between the real plate width and the nominal plate width: A user models a plate beam using the profile `PL200*10`, but then uses part or line cuts to create a 5 mm cut along the length of the plate, for example, to create a root opening for a weld, so that the end result is a plate which is only 195 mm wide. In this case, the real plate width would be 195 mm, and the nominal plate width 200 mm.

NOTE This advanced option only affects the profile definition, such as `PL10*200`, and it only affects if you have included the width into the profile definition by setting [XS_DSTV_PLATE_PROFILE_WITH_WIDTH](#) (page 212) to `TRUE`.

This advanced option is model specific and the setting is saved in the options database.

5.168 XS_DSTV_USE_COUNTERSUNK_HOLES

Category: CNC

If you set `XS_DSTV_USE_COUNTERSUNK_HOLES` to `FALSE` in **File menu** --> **Settings** --> **Advanced options** --> **CNC**, Tekla Structures will not create CSK holes in DSTV export. The default value is `TRUE`.

This advanced option is model specific and the setting is saved in the options database.

5.169 XS_DSTV_USE_EQUAL_ACCURACY_FOR_PLATE_PROFILE_AND_WIDTH

Category

CNC

Set this advanced option to `TRUE` if you want the plate profile width value, plate width value in header and y coordinate values in AK and IK blocks to be rounded to the nearest millimeter. The default value is `FALSE`.

This advanced option is model specific and the setting is saved in the options database.

5.170 XS_DSTV_USE_ONE_VERTEX_SHARP INNER CORNER

Category

CNC

Set this advanced option to `TRUE` if you do not need to add additional vertex points in the AK block of your DSTV file, for example, when you do not define the rounding radius in the NC settings. By default, this advanced option is set to `FALSE`, which means that additional vertex points are added.

This advanced option is model specific and the setting is saved in the options database.

Example

Results in the following DSTV file when the advanced option is set to `TRUE`:

| AK | | | | | | | |
|----|---------|---------|------|--------|------|------|------|
| v | 0.00s | 0.00 | 0.00 | 0.00 | 0.00 | 0.00 | 0.00 |
| | 4000.00 | 0.00 | 0.00 | 0.00 | 0.00 | 0.00 | 0.00 |
| | 4000.00 | 200.00 | 0.00 | 0.00 | 0.00 | 0.00 | 0.00 |
| | 123.88 | 200.00 | 0.00 | -14.03 | 9.00 | 0.00 | 0.00 |
| | 123.88 | 150.00w | 0.00 | 0.00 | 0.00 | 0.00 | 0.00 |
| | | | | | | | |
| | 0.00 | 150.00 | 0.00 | 0.00 | 0.00 | 0.00 | 0.00 |
| | 0.00 | 0.00 | 0.00 | 0.00 | 0.00 | 0.00 | 0.00 |

Results in the following DSTV file when the advanced option is set to `FALSE`.

| AK | | | | | | | |
|----|---------|---------|------|--------|------|------|------|
| v | 0.00s | 0.00 | 0.00 | 0.00 | 0.00 | 0.00 | 0.00 |
| | 4000.00 | 0.00 | 0.00 | 0.00 | 0.00 | 0.00 | 0.00 |
| | 4000.00 | 200.00 | 0.00 | 0.00 | 0.00 | 0.00 | 0.00 |
| | 123.88 | 200.00 | 0.00 | -14.03 | 9.00 | 0.00 | 0.00 |
| | 123.88 | 150.00 | 0.00 | 0.00 | 0.00 | 0.00 | 0.00 |
| | 125.00 | 150.00w | 0.00 | 0.00 | 0.00 | 0.00 | 0.00 |
| | 0.00 | 150.00 | 0.00 | 0.00 | 0.00 | 0.00 | 0.00 |
| | 0.00 | 0.00 | 0.00 | 0.00 | 0.00 | 0.00 | 0.00 |

5.171 XS_DSTV_USE_REAL_DIMENSIONS_IN_HEADER

Category: CNC

Set to `TRUE` to have bounding box values of the height and width written to the profile header data in the NC file. The default value is `FALSE`.

This advanced option is model specific and the setting is saved in the options database.

5.172 XS_DSTV_WRITE_BEHIND_FACE_FOR_PLATE

Category

CNC

Set to `TRUE` to write (AK + IK) contours for front (v) and back (h) faces of plates in NC DSTV files. Set to `FALSE` to Tekla Structures only write the front face for plate profiles. The default value is `FALSE`.

This advanced option is user specific and the setting is saved in `options.bin` under the user folder, for example, in `C:\Users\\AppData\Local\Trimble\Tekla Structures\\UserSettings`. Restart Tekla Structures to activate the new value.

5.173 XS_DUPLICATE_CHECK_LIMIT_FOR_COPY_AND_MOVE

Category

Modeling Properties

Use to define the maximum number of objects that are checked for duplicates while copying or moving objects.

If the selection contains too many objects, Tekla Structures does not check for duplicates. Enter an integer value. The default value is 100.

This advanced option is user specific and the setting is saved in `options.bin` under the user folder, for example, in `C:\Users\\AppData\Local\Trimble\Tekla Structures\\UserSettings`. Restart Tekla Structures to activate the new value.

See also

5.174 XS_DWG_EXPORT_UPDATE_TS_LINEWORK_OPTION

Category: Export

The setting **Update Tekla Structures linework only** is only shown in the **Export drawings as DWG/DXF** dialog box if you have set the new advanced option `XS_DWG_EXPORT_UPDATE_TS_LINEWORK_OPTION` to `TRUE`. **Update Tekla Structures linework only** updates the Tekla Structures drawing content only and keeps other content that is created in a CAD software intact at the same file. Blocks (groups), created by Tekla Structures will be updated. Note that you need to have the same drawing exported already, and the layer setup and the layer template must be the same as during the previous export. All CAD lines that were added previously will stay in the file and only Tekla Structures content will get updated, unless editing was done in CAD blocks editor. The default value is `FALSE`.

This setting is user specific, and it is saved in the `options.bin` under the user folder.

Note that if you edit content of a block (CAD object), and then select the **Update Tekla Structures linework only** option, the whole block will be re-written, and the changes made in CAD will not be kept. To keep the changes in CAD, you need to explode a block before editing it.

For example, you may want to use this option if you have added drawing title blocks in the CAD after the first export of the drawing from Tekla Structures, and want to keep these tables as they are, and update only the objects that exported from Tekla Structures.

5.175 XS_DWG_IMPORT_IGNORE_UNITS

Category

This advanced option must be set in an initialization (.ini) file.

If a DWG reference file is created with imperial settings, it will import to Tekla Structures in too large scale. You can use this advanced option to prevent this.

If you want all coordinates to be meters, set this advanced option to `TRUE`. If you want to take the unit from the DWG file based on the measurement and \$insunit definitions in the file header, leave the value out. By default, this advanced option is not set to any value.

5.176 XS_DXF_FONT_CONVERSION_FILE

Category: Printing

NOTE This advanced option only applies to the old DWG or DXF drawing export.

Use this advanced option to specify a font conversion file for the old Tekla Structures drawing DWG and DXF export and printing. The font conversion file defines which font file will be connected to the created AutoCAD style, and optional font width and height correction factors. You can use both True Type font files and AutoCAD .SHX font files.

If only the file name of the font conversion file is given, the file is read from the model folder. To use a font conversion file from another location, give the file name with relative or full path. If `XS_DXF_FONT_CONVERSION_FILE` is not set, Tekla Structures will try to use the default font conversion file (`dxfontools.cnv`) from the folder defined by `DXK_FONTPATH`. `DXK_FONTPATH` is defined in `teklastructures.ini`.

If the font conversion file is not found or if it does not contain a mapping for a certain font, the font name used in Tekla Structures is used to form the name of the text style in AutoCAD. Spaces are replaced with underscores and lowercase letters are replaced with uppercase ones. For example, font name Arial Narrow in Tekla Structures will become a style named `ARIAL_NARROW` in AutoCAD.

In addition to the font-specific width and height correction factors defined in the font conversion file, there are general variables `XS_DXF_TEXT_HEIGHT_FACTOR` and `XS_DXF_TEXT_WIDTH_FACTOR`, which apply to all exported texts regardless of the font. If both font specific factors and general variables are used, they are multiplied.

Syntax used in font mapping:

```
Font name in Tekla Structures = Font file name in AutoCAD [*  
width correction factor [* height correction factor]]
```

Examples of font mappings in a `.cnv` file:

```
Arial Narrow = ARIALN.TTF
```

```
Arial Narrow Bold Italic = ARIALNBI.TTF * 0.5 * 1.0
```

- NOTE**
- The names in the font conversion file are case sensitive.
 - The font conversion file is used for drawings in DWG and DXF export and printing only, it does not affect drawings DWG and DXF import or model import or export.
-

See also

[DXK_FONTPATH \(page 218\)](#)

[XS_DXF_TEXT_HEIGHT_FACTOR \(page 218\)](#)

[XS_DXF_TEXT_WIDTH_FACTOR \(page 218\)](#)

5.177 XS_DXF_FONT_NAME

Category

Printing

Use to specify a font other than the default for 2D DXF files. By default, this advanced option is not set to any value.

This advanced option is model specific and the setting is saved in the options database.

5.178 XS_DXF_TEXT_HEIGHT_FACTOR

Category

Printing

Use to set a scale factor for 2D DXF text height. Enter the factor as a decimal. The default value is 1.0.

This advanced option is model specific and the setting is saved in the options database.

5.179 XS_DXF_TEXT_WIDTH_FACTOR

Category

Printing

Use to set the scale factor for 2D-DXF text width. Enter the factor as a decimal. The default value is 1.0.

This advanced option is model specific and the setting is saved in the options database.

5.180 DXK_FONTPATH

This advanced option must be set in an initialization (.ini) file.

This advanced option is system specific and is read from `teklastructures.ini`. It can also be set locally, see your environment `.ini` file (`env_<environment_name>.ini`). Generally, there is no need to modify system-specific settings. Do not modify them if you are not an administrator.

Use to point to the folder containing Tekla Structures graphic fonts. The Template editor, for example, uses graphic fonts. `DXK_FONTPATH` is defined in `teklastructures.ini`.

Always end the path with the backslash character.

Example

```
set DXK_FONTPATH=%XSDATADIR%\environments\common\fonts\
```

5.181 DXK_SYMBOLPATH

This advanced option must be set in an initialization (.ini) file.

This advanced option is system specific and is read from `teklastructures.ini`. It can also be set locally, see your environment `.ini` file (`env_<environment_name>.ini`). Generally, there is no need to modify system-specific settings. Do not modify them if you are not an administrator.

This advanced option points to one or several folders containing Tekla Structures symbol libraries. These folders also contain the DWG files used in snap symbols and handles. The order of folders in `DXK_SYMBOLPATH` is significant: If there are duplicate files, the first one found is used. All files are read from all defined folders. Folders defined for `DXK_SYMBOLPATH` are searched before the model folder. The file search order for symbols is explained here: [Symbol file search order](#).

The `DXK_SYMBOLPATH` is defined in the environment initialization file `env_<environment_name>.ini`, located in `..\Trimble\Tekla Structures\<version>\<environments>\<your_environment>`, and in the Tekla Structures initialization file `teklastructures.ini` located in the `..\Tekla Structures\<version>\bin\` folder.

Separate different folder paths with a semicolon (;). Always end a folder path with a backslash character.

Example

Example with one folder:

```
DXK_SYMBOLPATH=C:\ProgramData\Trimble\Tekla Structures  
\<version>\environments\common\symbols\
```

Example with several folders:

```
DXK_SYMBOLPATH=%XS_FIRM%;%XSDATADIR%\environments\uk\General  
\symbols\;%XSDATADIR%\environments\common\symbols\
```

In the latter example, Tekla Structures first checks your own symbol files in your firm folder, then the symbol files in the UK environment symbols folder, and last the symbol files in the common environment symbols folder. If a duplicate file exists, the one that Tekla Structures finds first is used.

Using a firm folder for images and symbols

You can define a firm folder where Tekla Structures always searches for the images and symbols. When you store the images and symbols in this folder, you do not have to move them from folder to folder when you install a new version of Tekla Structures. Installing a new version does not replace the files in the firm folder.

6 Advanced options - E

6.1 XS_ENABLE_FAST_CUSTOM_PROPERTY_LOADING

This advanced option must be set in startup .ini files

To switch off the functionality of loading custom properties from the extension folder `..common\extensions\custom\properties\`, set the advanced option `XS_ENABLE_FAST_CUSTOM_PROPERTY_LOADING` to `FALSE` in a startup `.ini` file using the following command:

```
set XS_ENABLE_FAST_CUSTOM_PROPERTY_LOADING=FALSE
```

When you do this, the custom properties are loaded from all folders and subfolders in `..common\extensions`, and from the locations defined in `XS_EXTENSION_DIRECTORY`. This may cause performance issues and loading failures when custom properties are used.

Loading custom properties from `..common\extensions\custom\properties\` speeds up the loading process and solves loading problems caused by other software components in other extension folders.

6.2 XS_ENABLE_INNER_CONTOURS_IN_CUT_PARTS

Category

Speed and Accuracy

Set this advanced option to `TRUE` to have Tekla Structures create a part cut according to the inner and outer surfaces of the cutting part.

When the advanced option is set to `FALSE`, Tekla Structures creates the cut according to the outer surface of the cutting part. This is the default.

This advanced option is model specific and the setting is saved in the options database.

Example

Here a beam has been cut with a round tube.

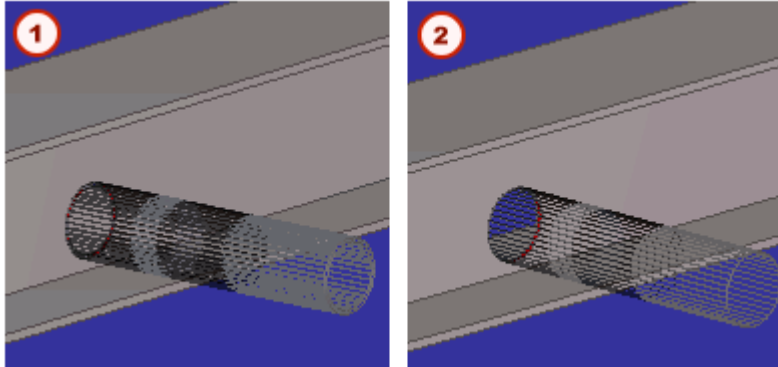

- ① Advanced option set to `TRUE`
- ② Advanced option set to `FALSE`

6.3 XS_ENABLE_MIDDLE_BUTTON_DOUBLE_CLICK_ZOOM_ORIGINAL

Category

This advanced option must be set in an initialization (.ini) file.

When you set this advanced option to `TRUE` and double-click the middle mouse button, Tekla Structures zooms the open drawing to its original size.

Example

```
XS_ENABLE_MIDDLE_BUTTON_DOUBLE_CLICK_ZOOM_ORIGINAL=TRUE
```

6.4 XS_ENABLE_PHASE_OPTION_IN_NUMBERING

Category: Numbering

When this advanced option is set to `FALSE` (which is the default value), the **Assembly phase** check box is disabled in the **Numbering Setup** dialog box. This means that changing an object's phase does not affect numbering or trigger change alerts.

If this advanced option is set to `TRUE`, the **Assembly phase** check box is enabled in the **Numbering Setup** dialog box. This is the recommended setting for Tekla Model Sharing users.

If you select the **Assembly phase** check box, only the assembly phase of each assembly is compared in numbering. This means that otherwise identical objects with different assembly phase get the same part position number.

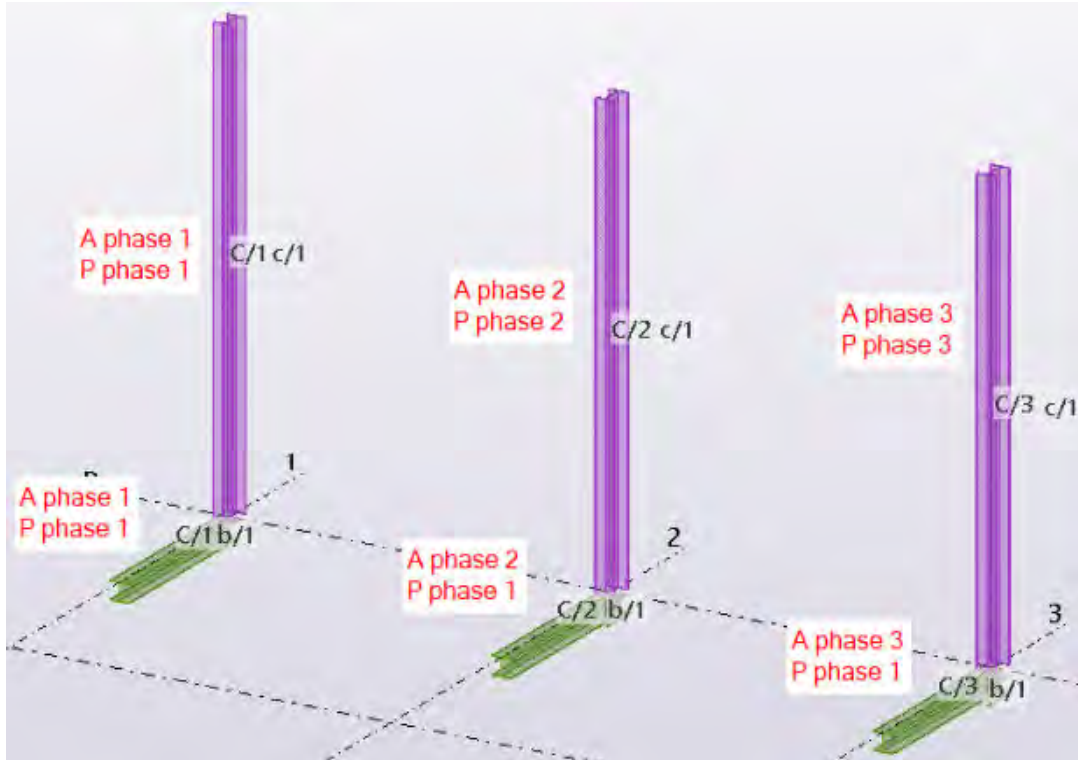

Note! Even if you **do not** select the **Assembly phase** check box, but you change the phase of an object when

`XS_ENABLE_PHASE_OPTION_IN_NUMBERING` is set to `TRUE`:

- A question mark (?) is added to the object's position number indicating that numbering is needed.
- After renumbering, the **Document manager** indicates that the drawings need updating.
- In shared models, the **Changes** list shows the changed parts and assemblies.

This happens even if you are using the Project Viewer configuration.

This advanced option is model specific and the setting is saved in the options database.

6.5 XS_ENABLE_POUR_MANAGEMENT

Category: Concrete Detailing

Set this advanced option to `TRUE` to enable pour management in the currently open model and to show cast-in-place concrete structures as continuous. The commands that show and create pour objects and pour breaks in the model and drawings are only available when pour management is enabled.

The default value for new models in the **Concrete contractor** role is `TRUE`. In the other standard roles, the default value for new models is `FALSE`.

This advanced option is model specific and the setting is saved in the options database.

WARNING If pour management is enabled in the model, do not disable it using `XS_ENABLE_POUR_MANAGEMENT`, especially in the middle of the project. This may cause problems if you have drawings containing pour objects, and if you are sharing your model. The pour objects and pour breaks in the model and in the drawings may get invalid, and you may lose pour-related modeling work.

6.6 XS_ENABLE_PRECAST_CONTINUOUS_CONCRETE

This advanced option must be set in an initialization (.ini) file.

Set this advanced option to `TRUE` to show precast concrete structures as continuous in model views. Showing precast concrete structures as continuous means that, within each cast unit, the concrete parts with the same material grade and the cast unit type **Precast** are shown as merged so that the part outlines between touching or overlapping parts are not visible.

Note that you also need to set [XS_ENABLE_POUR_MANAGEMENT \(page 223\)](#) to `TRUE` in the **Advanced options** dialog box.

The default value of `XS_ENABLE_PRECAST_CONTINUOUS_CONCRETE` is `FALSE`, which means that the outlines of precast concrete parts within each cast unit are visible.

Restart Tekla Structures after changing the value to activate the new setting.

When `XS_ENABLE_PRECAST_CONTINUOUS_CONCRETE` is set to `TRUE`, you can adjust how the precast concrete structures appear in each model view by using the following display settings of cast-in-place concrete structures in **View Properties** --> **Display**:

- Ensure that **Cast in place** is set to **Parts**.
- In the **Cast in place parts** list, select either **Merged** or **Separated** to hide or show the touching or overlapping part outlines.

6.7 XS_ENABLE_PULLOUT_PLACEHOLDERS

Category: Concrete Detailing

Set this advanced option to `TRUE` to add placeholders instead of dimensions in pull-out pictures. This advanced option adds the option **Placeholders** in the **Pullout picture** dialog box.

Pullout picture

Scale by

Auto

One factor: 1.0

Two factors: x: 1.0 y: 1.0

Rotation: Plane

End marks: —

Dimensions

Exaggeration

Bending radius

Bending angle

Couplers/end anchor symbols Scale: 0.00

Placeholders

OK Modify Cancel

The following example shows how the placeholders are used:

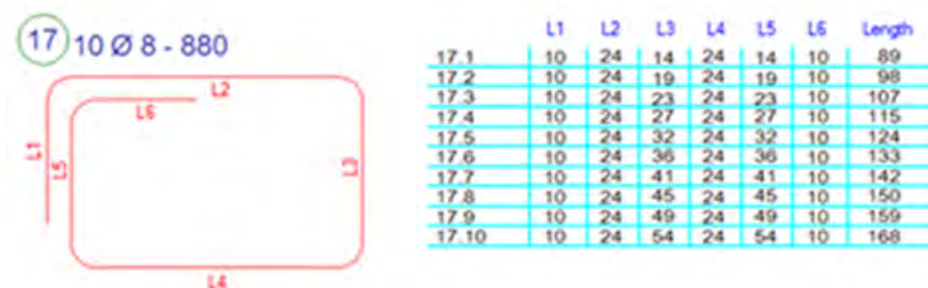

This advanced option is model specific and the setting is saved in the options database.

6.8 XS_ENTER_FINALIZES_COMMANDS

Category: Modeling properties

Use this advanced option to set the **Enter** key as a shortcut for completing commands. This advanced option applies also to the direct modification commands.

By default, the advanced option is set to `TRUE`.

6.9 XS_ENABLE_OVERLAPPING_CUT_LINE_REMOVAL

Category: Drawing properties

This advanced option controls the removal of overlapping cut or non-solid lines. It is by default set to `TRUE`, and the overlapping cut and non-solid (dashed, dash-and-dot) lines are removed.

Do not set this advanced option to `FALSE`. If you do that, the cut and non-solid lines may become misaligned and look like solid lines in drawings, and hidden objects may be presented as not hidden, for example.

Note that this advanced option does not remove cut or non-solid lines that are added manually to the drawing.

`XS_ENABLE_OVERLAPPING_CUT_LINE_REMOVAL` set to `TRUE`:

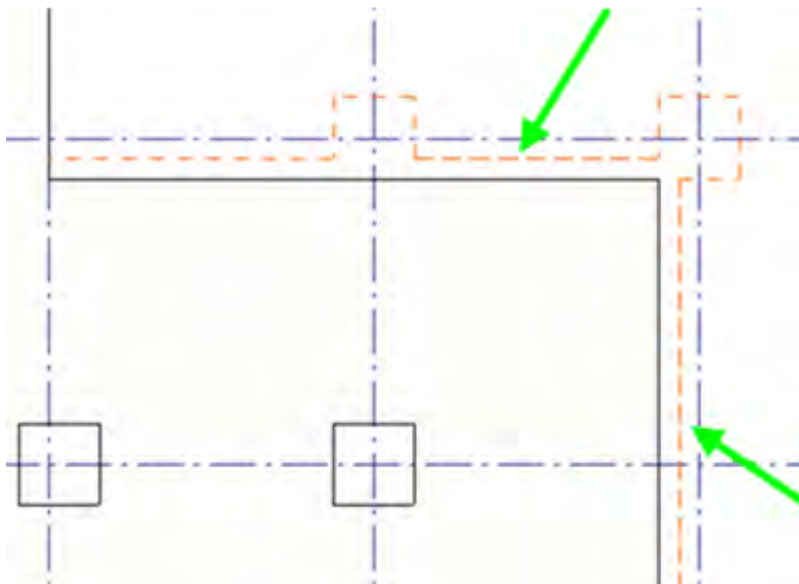

`XS_ENABLE_OVERLAPPING_CUT_LINE_REMOVAL` set to `FALSE`:

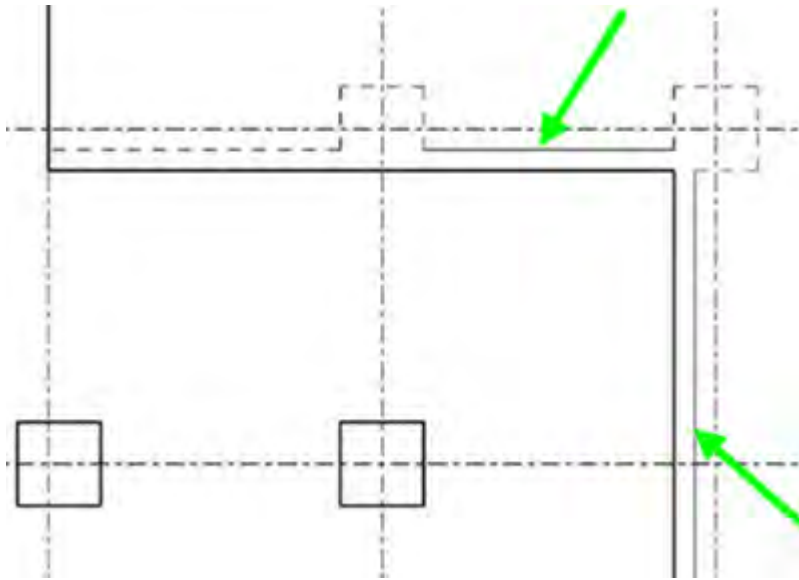

This advanced option is model specific and the setting is saved in the options database.

6.10 XS_ENABLE_REBAR_MARK_LEADER_LINE_BASE_POINT_OPTIMIZATION

Category: Concrete detailing

Use to select an optimal place for the associativity point of the reinforcing bar mark leader line. If set to `TRUE`, Tekla Structures selects an optimal place for the associativity point. The associativity point only points to one reinforcing bar instead of an intersection or overlap of multiple bars.

The optimization is only applied to the marks that have the **Placing method** value **Free**. In practice, this prevents the optimization from moving manually moved marks, because moving a mark manually changes the value of its **Placing method** to **Fixed**. The default value is `TRUE`.

This advanced option is model specific and the setting is saved in the options database.

6.11 XS_EQUAL_SHAPE_DIMENSIONS_TO_BOTH_ENDS_LIMIT

Category

Dimensioning: Parts

Shape dimensions are automatically shown on both ends of a beam, even if the dimensions are the same. You can change this by entering a value in millimeters for this advanced option.

This advanced option is role specific. When the type **SYSTEM(ROLE)** is in use, the default value is used. When the type **MODEL(ROLE)** or **DRAWING(ROLE)** is in use, you can change the value, which is then the same for all users in the current model.

Example

If you set this advanced option to 300, and a part is 300 mm shorter in one direction, Tekla Structures only displays the dimension in the longer direction. Use millimeters in all environments.

6.12 XS_ERASE_UDA_VALUE_WITH_ATTRIBUTE_IMPORT_NULL_AND_BLANK

Category

This advanced option must be set in an initialization (.ini) file.

Set to `TRUE` to erase the values of selected user-defined attributes in attribute import.

To select which values of user-defined attributes are erased, enter any of the following values at the end of the file to be imported, in the same order as the user-defined attributes are entered in the file:

- `NULL`
- `null`
- No value (two consecutive delimiters)

Example

If the content of the input file is the following:

```
ID; USER_FIELD_1; USER_FIELD_2; USER_FIELD_3; USER_FIELD_4;  
12345;NULL;null;;4
```

The result is:

User-defined attribute values for 1-3 are erased in the attribute import. User-defined attribute 4 has the value 4 in the attribute import.

NOTE Space and tab are not recommended as delimiters in the input file when this functionality is used.

6.13 XS_EXCLUDED_PARTS_IN_ORIENTATIONAL_NUMBERING

Category: Numbering

The advanced option `XS_EXCLUDED_PARTS_IN_ORIENTATIONAL_NUMBERING` can be used in conjunction with the orientation numbering setting. Similar parts will be numbered the same even if their orientation is different and the orientation setting has been selected in the **Numbering Setup** dialog box. You can enter the desired part names separated by spaces. Wildcards are also allowed. This advanced option is model specific and the setting is saved in the options database.

6.14 XS_EXPORT_BREP_AS_EXACT_SOLID

Category: Export

Set this advanced option to `TRUE` to export B-rep objects as exact solids in the IFC2x3 export. `FALSE` is the default value.

Note that if you export B-reps as exact solids, the IFC file size increases, and the export takes more time.

TIP To get smoother edges to the export, you may need to set the advanced option `XS_CS_CHAMFER_DIVIDE_ANGLE` ([page 229](#)) to 10.

In the following example, on the left, you can see a native type I profile, and on the right the IFC object surface geometry when both advanced options are used:

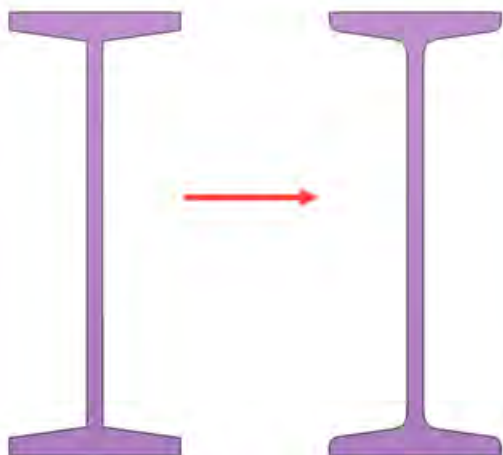

This advanced option is model specific and the setting is saved in the options database.

See also

[XS_CS_CHAMFER_DIVIDE_ANGLE \(page 111\)](#)

6.15 XS_EXPORT_CODEPAGE

Category

Export

Tekla Structures sets the codepage automatically so that exported files are displayed correctly. If the proper codepage cannot be found, the codepage is set to `ansi_1252` by default. You can set the codepage manually by using this advanced option, which overrides the automatic selection of codepage in export. By default, this advanced option is not set to any value.

This advanced option is user specific and the setting is saved in `options.bin` under the user folder, for example, in `C:\Users\<user>\AppData\Local\Trimble\Tekla Structures\<version>\UserSettings`. Restart Tekla Structures to activate the new value.

To set the advanced option to the required codepage, use one of the following values:

- `ascii`
- `iso8859-1`
- `iso8859-2`
- `iso8859-3`
- `iso8859-4`
- `iso8859-5`
- `iso8859-6`
- `iso8859-7`
- `iso8859-8`
- `iso8859-9`
- `dos437`
- `dos850`
- `dos852`
- `dos855`
- `dos857`
- `dos860`
- `dos861`

- dos863
- dos864
- dos865
- dos869
- dos932
- mac-roman
- big5
- ksc5601
- johab
- dos866
- ansi_1250
- ansi_1251
- ansi_1252
- gb2312
- ansi_1253
- ansi_1254
- ansi_1255
- ansi_1256
- ansi_1257
- ansi_874
- ansi_932
- ansi_936
- ansi_949
- ansi_950
- ansi_1361
- ansi_1200
- ansi_1258

6.16 XS_EXPORT_DGN_COORDINATE_SCALE

Category

Export

Use this advanced option to set the coordinate scale to use in DGN exports. DGN coordinate scale does not actually scale the model, but changes the model precision. If you set this advanced option to 100, the accuracy is 1/100 mm.

This advanced option is model specific and the setting is saved in the options database.

6.17 XS_EXPORT_DGN_FILENAME

Category

This advanced option must be set in an initialization (.ini) file.

This advanced option has been removed.

Use to indicate the output file name in DGN exports. The default is `model.dgn`.

6.18 XS_EXPORT_DGN_INCLUDE_CUTS

Category

Export

Use this advanced option to define the cuts to include in DGN exports. You can use the following values:

| Value | Use to |
|-----------------------------|--|
| FALSE | Exclude all cuts. |
| TRUE | Include all cuts (default value). |
| CLASH | Include all cuts but skip hole cut ends. |
| CLASH_NOR MAL_PLATE S | Same as TRUE for contour plates and CLASH for all other parts. |

This advanced option is model specific and the setting is saved in the options database.

6.19 XS_EXPORT_DGN_INCLUDE_INNER_CONTOUR

Category

Export

Use to include or exclude inner contours of tubes in DGN exports. The options are:

- `TRUE` to include inner contours (default)
- `FALSE` (default) to exclude inner contours

This advanced option is model specific and the setting is saved in the options database.

6.20 XS_EXPORT_DGN_ROUND_SEGMENTS

Category

Export

Use to define the number of segments Tekla Structures uses to display round tubes. Tekla Structures uses this value for large tubes (larger than 100 mm) and 80% of this value for small tubes. The default value is 40.

This advanced option is model specific and the setting is saved in the options database.

6.21 XS_EXPORT_DGN_USE_CLASS_AS_COLOR

Category

Export

Set the color for exported parts by the part class (like **Color by class** in the model).

By default the export uses the current colors of the Tekla Structures view (`FALSE`). Set this advanced option to `TRUE` when you have defined some other color setting than **Color by class** in the **Object Representation** dialog box, but still want to export with **Color by class**.

This advanced option is model specific and the setting is saved in the options database.

6.22 XS_EXPORT_DGN_USE_VOLUMETRIC

Category

Export

Set this advanced option to `TRUE` to define plates with profile type plate or polygon plate to DGN type attribute 92 (0x05C in DGN cell header) and all other beams to DGN type attribute 91 (0x05B in DGN cell header) in DGN export. If you set it to `FALSE`, all beams get 91 as the type attribute in DGN export. The default value is `FALSE`.

When this advanced option is set to `TRUE`, mapping to Microstation is successful and the attribute report in Tekla Structures is correct.

This advanced option is model specific and the setting is saved in the options database.

6.23 XS_EXPORT_DRAWING_TRY_TO_KEEP_LOCATION

This advanced option must be set in an initialization (.ini) file.

If you set the advanced option

`XS_EXPORT_DRAWING_TRY_TO_KEEP_LOCATION` to `TRUE` (default), Tekla Structures tries to keep the DWG origin in the same position in the drawing export as the drawing view origin. This can only be done in plan views and elevation views. If the drawing has more than one plan view or elevation view, Tekla Structures places the DWG origin in the bottom-left corner of the drawing frame.

If you set this advanced option to `FALSE`, the origin (0,0) is set to the bottom-left corner of the drawing frame.

This advanced option is system specific and is read from `teklastructures.ini`. Generally, there is no need to modify system-specific settings. Do not modify them if you are not an administrator.





6.24 XS_EXPORT_FILLMODE

Category

Export

Use to control how fills are exported to DWG and DXF formats.

This advanced option is model specific and the setting is saved in the options database.

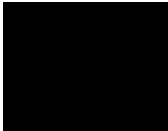
| Value | Description | Appearance in exported DWG/DXF | Appearance in Tekla Structures |
|--------|--|--|---|
| HATCH | Fills are drawn as hatches in the exported DWG/DXF. This is the default value. |  |  |
| BORDER | Only the border lines of fills are drawn in the exported DWG/DXF. |  | |
| FILL | Fills are drawn as filled triangles in the exported DWG/DXF. |  | |
| NONE | Fills are not drawn in the exported DWG/DXF. |  | |

6.25 XS_EXPORT_IFC_REBARSET_INDIVIDUAL_BARS

Category: Export

Use this advanced option to control how rebars created by rebar sets are exported in the IFC2x3 and IFC4 export. To export the bars in groups, set this advanced option to `FALSE` (default), and to export the bars as individual bars, set it to `TRUE`.

NOTE In the IFC file, 'Total number' always shows 1 for groups created by rebar sets and 'Total weight' and 'Weight' show one bar weight. Use the `NUMBER_OF_BARS_IN_GROUP` and `WEIGHT_TOTAL_IN_GROUP` properties to export the values of the group to the IFC file.

This advanced option is model specific and the setting is saved in the options database.

6.26 XS_EXPORT_LINE_TYPE_DEFINITION_FILE

Category: Export

Enter the name of the line type definition file that contains the line type definitions and is used in line type mapping.

The file name extension of the line type definition file is `.lin`. The advanced option is set to point to the file `TeklaStructures.lin` by default.

This advanced option is user specific and the setting is saved in `options.bin` under the user folder, for example, in `C:\Users\\AppData\Local\Trimble\Tekla Structures\\UserSettings`. Restart Tekla Structures to activate the new value.

6.27 XS_EXPORT_STEEL2000_PRIMARY_IDS

Category

Drawing Properties

Set to `TRUE` to have Tekla Structures include main part IDs in MIS export files. IDs appear on separate rows in the file. The default value is `FALSE`.

This advanced option is model specific and the setting is saved in the options database.

6.28 XS_EXTENSION_DIRECTORY

This advanced option must be set in an initialization (.ini) file.

Use the advanced option `XS_EXTENSION_DIRECTORY` for defining additional installation folders for extensions, or customer tools developed on top of Open API.

Before the additional installation folders, the default folder `%XSDATADIR%\environments\common\extensions` is used in installation.

6.29 XS_EXTERNAL_EXCEL_DESIGN_PATH

This advanced option must be set in an initialization (.ini) file.

This advanced option is system specific and is read from `teklastructures.ini`. It can also be set locally, see your environment `.ini`

file (`env_<environment_name>.ini`). Generally, there is no need to modify system-specific settings. Do not modify them if you are not an administrator.

Points to the location of the Excel spreadsheet used in connection design. If you want to change the location, set the advanced option in the `user.ini` file.

7 Advanced options - F

7.1 XS_FILTER_SEPARATOR_CHAR

Category

Modeling properties

Enter the separator to be used between filter strings, for example, in the view filter. You can use any character. By default Tekla Structures uses a space.

Example

To use a semi-colon as a separator, set this advanced option as follows:

```
XS_FILTER_SEPARATOR_CHAR=;
```

This advanced option is model specific and the setting is saved in the options database.

7.2 XS_FIRM

Category: File locations

NOTE This advanced option is system-specific and only meant for administrators.

Set the advanced options `XS_PROJECT` and `XS_FIRM` along with `XS_SYSTEM` to point to the folders Tekla Structures searches for property files. Tekla Structures always saves properties in the current `<model>\attributes` folder. You can then copy or move them to the `XS_FIRM` or the `XS_PROJECT` folder if the same settings are needed in other models. You can also create user-defined sub-folders under the `XS_FIRM` and the `XS_PROJECT` folders,

and copy or move property files from the <model>\attributes folder to these sub-folders.

For shared models, you can use a sub-folder in a Trimble Connect project as the firm folder. For more information, see "Best practices in Tekla Model Sharing".

Note that you can define one path only, not a list of paths.

WARNING Changing an advanced option value in .ini files located outside the model folder does not affect the existing models. You can only update advanced options in the **Advanced Options** dialog box or in the options.ini file located in model folder; not from an options.ini file located in folders defined for the advanced options XS_FIRM or XS_PROJECT. The .ini files are read also when you open an existing model, but only new advanced options that do not exist in options_model.db or options_drawings.db are inserted, for example, such options that are not yet in the **Advanced Options** dialog box but have been added in the software.

7.3 XS_FIX_FRAME_OF_FIXED_MODELVIEW

Category

Drawing Properties

This advanced option prevents the changing of the view size and location especially in general arrangement drawings.

Set to TRUE to fix the frames of views that have **Placing** set to **Fixed in View Properties**. The default value is FALSE.

This advanced option is model specific and the setting is saved in the options database.

7.4 XS_FLAT_PREFIX

Category

Plate Work

Use this advanced option to set the flat bar prefix for output, reports, and marks. If Tekla Structures finds a matching flat bar in the fltprops.inp file, the plate name will consist of the prefix you enter here, followed by the thickness X width, for example FLAT5X100. The default value is FLAT.

By default PL and PLT profiles get the prefix FL or FLT if a matching plate is found in the `fltprops.inp`.

This advanced option is role specific. When the type **SYSTEM(ROLE)** is in use, the default value is used. When the type **MODEL(ROLE)** or **DRAWING(ROLE)** is in use, you can change the value, which is then the same for all users in the current model.

NOTE In Imperial version, if `XS_FLAT_PREFIX` is not included in `profitab.inp` as similar profile as PL (valid parametric profile name), the profile is shown with metric units.

7.5 XS_FLAT_THICKNESS_TOLERANCE

Category: Plate work

Use to set the checking tolerance for flat bars. Tekla Structures uses this value to check plate thickness to determine whether to convert it to a flat bar. Enter a decimal value. The default value is 0.1 mm.

This advanced option is model specific and the setting is saved in the options database.

7.6 XS_FLAT_TOLERANCE

Category: Plate work

Tekla Structures uses this value to check plate width to determine whether to convert it to a flat bar. Enter a decimal value. The default value is 0.1 mm.

This advanced option is model specific and the setting is saved in the options database.

7.7 FLEXLM_TIMEOUT

Category

This advanced option must be set in an initialization (.ini) file.

This is a Windows environment variable used by Tekla Structures. This variable reduces the delay in starting Tekla Structures. Enter the value in microseconds. For Tekla Structures, the maximum value of this variable is 100 000.

Example

```
set FLEXLM_TIMEOUT=100000
```

7.8 XS_FRACTION_HEIGHT_FACTOR

Category

Imperial Units

Use this advanced option to control the total height of fractions. The default value in the US environment Imperial role is 1.3.

This advanced option is model specific and the setting is saved in the options database.

7.9 XS_FS_POSTFIX_FOR_MERGED_PART_MARK

Category: Marking - parts

Use to define the far side (FS) postfix in merged part marks. This postfix is visible for identical parts on far side. FS is the default value.

This advanced option is model specific and the setting is saved in the options database.

In merging part marks, you may also find the following advanced options useful:

[XS_MULTIPLIER_SEPARATOR_FOR_MERGED_PART_MARK \(page 311\)](#)

[XS_NSFS_POSTIX_FOR_MERGED_PART_MARK \(page 315\)](#)

[XS_NS_POSTIX_FOR_MERGED_PART_MARK \(page 317\)](#)

[XS_PART_MERGE_MAX_DISTANCE \(page 327\)](#)

[XS_MIN_MERGE_PART_COUNT \(page 304\)](#)

8

Advanced options - G

8.1 XS_GA_CONNECTING_SIDE_MARK_SYMBOL

This advanced option must be set in an initialization (.ini) file.

Use to change the symbol for a connecting side mark in general arrangement drawings. By default, the side mark symbol is symbol number 34 in the `xsteel.sym` symbol file. To change the symbol, set this advanced option to a different symbol number.

Restart Tekla Structures after changing the value to activate the new setting.

See also

[XS_CONNECTING_SIDE_MARK_SYMBOL \(page 101\)](#)

8.2 XS_GA_DRAWING_VIEW_TITLE

Category

Drawing Properties

Use to define a title for a general arrangement drawing view in a multidrawing. By default the value is defined as follows:

Drawing %DRAWING_BASE_NAME%.

This advanced option is model specific and the setting is saved in the options database.

8.3 XS_GAGE_OF_OUTSTANDING_LEG_STRING

Category

Marking: Bolts

Use to display the gage of outstanding leg (GOL) information in bolt marks (element **Gage of outstanding leg**) in the following ways:

- If there is no %VALUE% in the string then Tekla Structures adds the GOL value to the end of the string.
- You can enter any combination of text together with option %VALUE%. For example, %VALUE% GOL or GOL%VALUE%.
- If you do not set this advanced option, Tekla Structures only uses %VALUE%.
- If Tekla Structures cannot calculate the value, nothing is added to the mark.
- The default value is GOL%VALUE%.

This advanced option is model specific and the setting is saved in the options database.

Example

Here, the value for the gage of outstanding leg is 5½.

| In the Advanced Options dialog box | In bolt mark |
|------------------------------------|--------------|
| %VALUE% GOL | 5½ GOL |
| GOSL %VALUE% | GOSL 5½ |
| GOL = | GOL = 5½ |
| | 5½ |

8.4 XS_GA_HIDDEN_NORTH_MARK_SYMBOL

Category

Marking: Parts

By default, the symbol for hidden North marks in general arrangement drawings is number 32 in the symbol file. To change the symbol, set this advanced option to a different symbol number.

See also

Show orientation marks (north marks)

8.5 XS_GA_NORTH_MARK_SCALE

Category

Marking: Parts

By default, Tekla Structures draws North marks in general arrangement drawings using a scale of 1:1. Use this advanced option to specify a different scale. You can also create a larger symbol for North marks in the Symbol Editor.

This advanced option is model specific and the setting is saved in the options database.

8.6 XS_GA_NORTH_MARK_SYMBOL

Category

Marking: parts

By default, the symbol for North marks in general arrangement drawings is number 32 in the symbol file. To change the symbol, set this advanced option to a different symbol number.

This advanced option is model specific and the setting is saved in the options database.

See also

Show orientation marks (north marks)

8.7 XS_GA_OMITTED_DIAMETER_TYPE

Category

Marking: bolts

Use to omit marks for specific diameter types in general arrangement drawings. The options are `HOLE` or `BOLT`.

This advanced option is model specific and the setting is saved in the options database.

See also

[XS_OMITTED_BOLT_TYPE](#) (page 321)

8.8 XS_GET_ASSEMBLY_LEVELS_FROM_ASSEMBLY_MAIN_PART

Category

Marking: Parts

Set this advanced option to `TRUE` to get assembly levels from the assembly main part. Set it to `FALSE` to get the levels from the whole assembly. The default value is `FALSE`.

This advanced option is model specific and the setting is saved in the options database.

8.9 XS_GET_CAST_UNIT_LEVELS_FROM_CAST_UNIT_MAIN_PART

Category

Marking: Parts

Set this advanced option to `TRUE` to get cast unit levels from the cast unit main part. Set it to `FALSE` to get the levels from the whole cast unit. The default value is `FALSE`.

This advanced option is model specific and the setting is saved in the options database.

8.10 XS_GOL_SYMMETRY_DISTANCE

Marking: Bolts

Gauge of outstanding leg (GOL) is the center to center distance of the holes between two angles usually connected on the web of the beam/column. It is equal to gauge of leg angles plus the web thickness. Outstanding leg is the leg of the angle perpendicular to the paper viewing from the web. Use this advanced option to set the tolerance in part symmetry checking when calculating the gauge of outstanding leg. The default value is 0.01.

This advanced option is model specific and the setting is saved in the options database.

8.11 XS_GRID_DIMENSION_OVERALL_LENGTH

Category

Dimensioning: General

Set a length to add a dimension line spanning the entire grid next to existing grid dimensions. The default value is 1.

This advanced option is user specific and the setting is saved in `options.bin` under the user folder, for example, in `C:\Users\\AppData\Local\Trimble\Tekla Structures\\UserSettings`. Restart Tekla Structures to activate the new value.

8.12 XS_GRID_COLOR_FOR_WORK_PLANE

Category: Model views

Use to change the color of the work plane grid in the model. Define the color of the grid using RGB values:

`<value for red> <value for green> <value for blue>`.

Separate the values with spaces. Define the values on a scale of 0 to 1. The default values are `0.7 0.0 0.3`.

Reopen the model view to activate the new value.

This advanced option is user specific and the setting is saved in `options.bin` under the user folder, for example, in `C:\Users\\AppData\Local\Trimble\Tekla Structures\\UserSettings`.

8.13 XS_GRID_PLANES_VISIBLE_WITH_USERPLANES

Category

Model View

Use to show or hide the grid planes.

Set to `TRUE` to show the grid planes. Set to `FALSE` (default) to hide the grid planes.

Reopen the view for the change to take effect.

NOTE The grid planes can be shown only if the construction planes are visible. To display the construction planes, select the **Construction planes** check box in the **Display** dialog box.

8.14 XS_GRID_TEXT_FONT

Category: Drawing properties

Use to set the font for grid text. The default values is Arial. If you do not specify a font, Tekla Structures uses the default font defined for [XS_DEFAULT_FONT](#) (page 116).

This advanced option is model specific and the setting is saved in the options database.

9 Advanced options - H

9.1 XS_HANDLE_SCALE

Category: Model views

Use to modify the handle size in model views. Enter a decimal value.

- The default value is 1.3.
- A value larger than 1.3 makes the handles larger and easier to see.
- A value smaller than 1.3 decreases the handles.

Close the model view and open it again to implement the change.

This advanced option is user specific, and the setting is saved in `options.bin` under the user folder.

9.2 XS_HATCH_PATTERN_LINE_LIMIT

Category: Hatching

Set this advanced option to a numerical value to control the maximum number of line segments created by a hatch pattern. The default value is 0, which means that there is no limit.

This advanced option is model specific and the setting is saved in the options database.

9.3 XS_HATCH_SCALE_LIMIT

Category

Hatching

Defines the smallest possible size of the drawn hatch pattern. If the scale of a single hatch pattern is smaller than the defined value, the pattern is changed to a solid face. The default value is 0.001.

This advanced option is model specific and the setting is saved in the options database.

9.4 XS_HATCH_SEGMENT_BUFFER_SIZE

Category

Hatching

Tekla Structures includes a hatch buffer to speed up opening drawings containing hatch. This advanced option defines the size of the buffer.

The default value is 1000000. If you use extremely complicated hatches, you may get better performance with a larger value. For small hatches, use a smaller value.

This advanced option is role specific. When the type **SYSTEM(ROLE)** is in use, the default value is used. When the type **MODEL(ROLE)** or **DRAWING(ROLE)** is in use, you can change the value, which is then the same for all users in the current model.

9.5 XS_HATCH_SPECIAL_COLOR_ACI

Category: Export

Use this advanced option to set the autocad color index for the **Special** color in hatches in drawing export. The default values is 120.

This advanced option is model specific and the setting is saved in the options database.

9.6 XS_HATCH_SPECIAL_COLOR_R

Category: Hatching

Use to define a hatch color that is not converted to black when printed. This color will be printed as color or grayscale, depending on the selected printer settings. The hatch color is defined using RGB (Red Green Blue) values on a scale of 0 to 255. The default for all of the related advanced options is 230.

Define the color using the following advanced options:

`XS_HATCH_SPECIAL_COLOR_R`

`XS_HATCH_SPECIAL_COLOR_G`

`XS_HATCH_SPECIAL_COLOR_B`

The smaller the values, the darker the shade.

This advanced option is model specific and the setting is saved in the options database.

9.7 XS_HATCH_SPECIAL_COLOR_G

Category: Hatching

Use to define a hatch color that is not converted to black when printed. This color will be printed as color or grayscale, depending on the selected printer settings. The hatch color is defined using RGB (Red Green Blue) values on a scale of 0 to 255. The default for all of the related advanced options is 230.

Define the color using the following advanced options:

`XS_HATCH_SPECIAL_COLOR_R`

`XS_HATCH_SPECIAL_COLOR_G`

`XS_HATCH_SPECIAL_COLOR_B`

The smaller the values, the darker the shade.

9.8 XS_HATCH_SPECIAL_COLOR_B

Category: Hatching

Use to define a hatch color that is not converted to black when printed. This color will be printed as color or grayscale, depending on the selected printer settings. The hatch color is defined using RGB (Red Green Blue) values on a scale of 0 to 255. The default for all of the related advanced options is 230.

Define the color using the following advanced options:

XS_HATCH_SPECIAL_COLOR_R

XS_HATCH_SPECIAL_COLOR_G

XS_HATCH_SPECIAL_COLOR_B

The smaller the values, the darker the shade.

9.9 XS_HELP_PATH

Category

This advanced option is available only in the `lang_<CurrentLanguage>.ini` files.

This advanced option specifies the location of the help files in `chm` (Microsoft Compiled HTML Help) format. These help files are used for some components.

This advanced option is system specific and is read from environment files. Generally, there is no need to modify system-specific settings. Do not modify them if you are not an administrator.

Example

```
set XS_HELP_PATH=%XSDATADIR%\help\enu
```

9.10 XS_HIDDEN_LINES_CHECK_TOLERANCE

Category

Drawing Properties

Defines the distance within which Tekla Structures treats part lines inside cast units as overlapping lines. The default value is `0.01`.

This advanced option is model specific and the setting is saved in the options database.

9.11 XS_HIDDEN_LINES_UNHIDE_EMBEDDED

Category: Drawing properties

Set this advanced option to `TRUE` to draw the edge lines of embedded parts as visible lines even when they are hidden inside concrete. `FALSE` is the default value.

Embed is a non-concrete (steel or miscellaneous) object in a cast unit or pour. It can be a sub-assembly, like steel objects always are in cast units, or a part in a pour.

Note that this advanced option does not affect reinforcement.

In the following two examples, one of the embeds is in the front/near face and the other is in the back/far face of the beam.

In the first example:

- `XS_HIDDEN_LINES_UNHIDE_EMBEDDED` is set to `TRUE`, so embed part lines are visible also when they are inside concrete.
- Cast unit lines are shown as outlines.
- Embed anchor studs have been created as rebars, and they are hidden, because **Hide lines behind parts** has been selected in reinforcement properties.

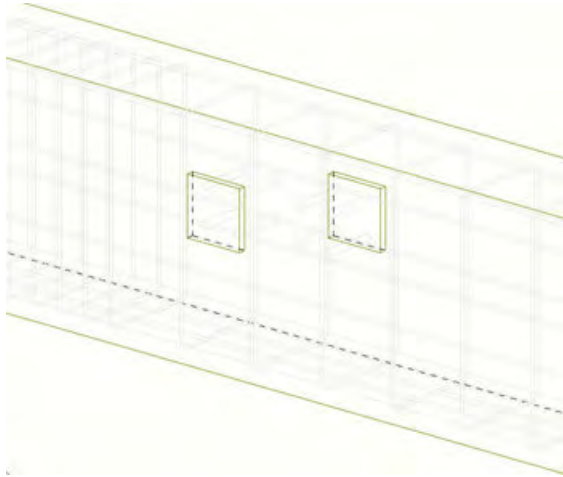

In the second example, `XS_HIDDEN_LINES_UNHIDE_EMBEDDED` is set to `FALSE`, so embed part lines that are inside concrete are hidden.

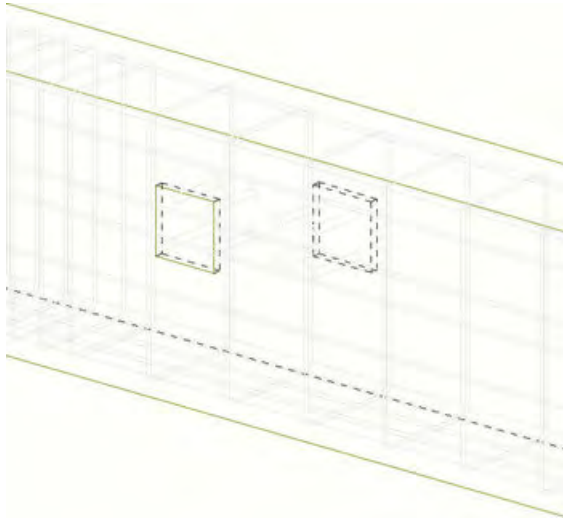

This advanced option is model specific and the setting is saved in the options database.

9.12 XS_HIDDEN_NORTH_MARK_SYMBOL

Category: Marking - parts

By default hidden North mark symbol is number 32 in the `xsteel.sym` symbol file. To change the symbol, set this advanced option to a different symbol number.

For more information about symbols in Tekla Structures, and checking the symbol files, see [Add symbols in drawings](#).

This advanced option is model specific and the setting is saved in the options database.

See also

[Show orientation marks \(north marks\)](#)

9.13 XS_HIDDEN_REMOVE_DOUBLE_LINES

Category: Drawing properties

To have Tekla Structures draw double lines when displaying models with **Exact** representation and creating drawings and 2D DWG/DXF files, set this advanced option to `FALSE`.

Note that on the screen, it is very difficult to notice the difference, but if you open the exported DWG file in a DWG editor, such as AutoCAD, you will more easily notice the difference, because you can select one or two lines in the file.

The default value is `TRUE`, which means that Tekla Structures does not draw double lines, to minimize file size.

This advanced option is model specific and the setting is saved in the options database.

9.14 XS_HIDDEN_USE_BOLT_PLANES

Category

Category Drawing properties

Set this advanced option to `TRUE` to hide lines behind a bolt nut (with **Exact** part representation). To show the lines, set it to `FALSE` (default).

This advanced option is user specific and the setting is saved in `options.bin` under the user folder, for example, in `C:\Users\\AppData\Local\Trimble\Tekla Structures\\UserSettings`. Restart Tekla Structures to activate the new value.

`TRUE:`

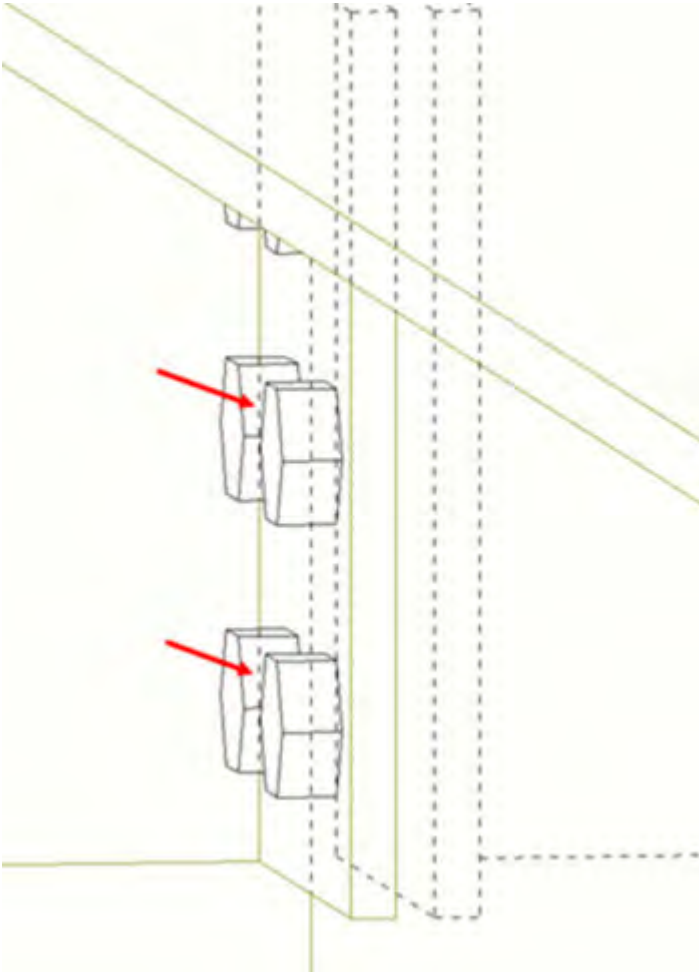

FALSE:

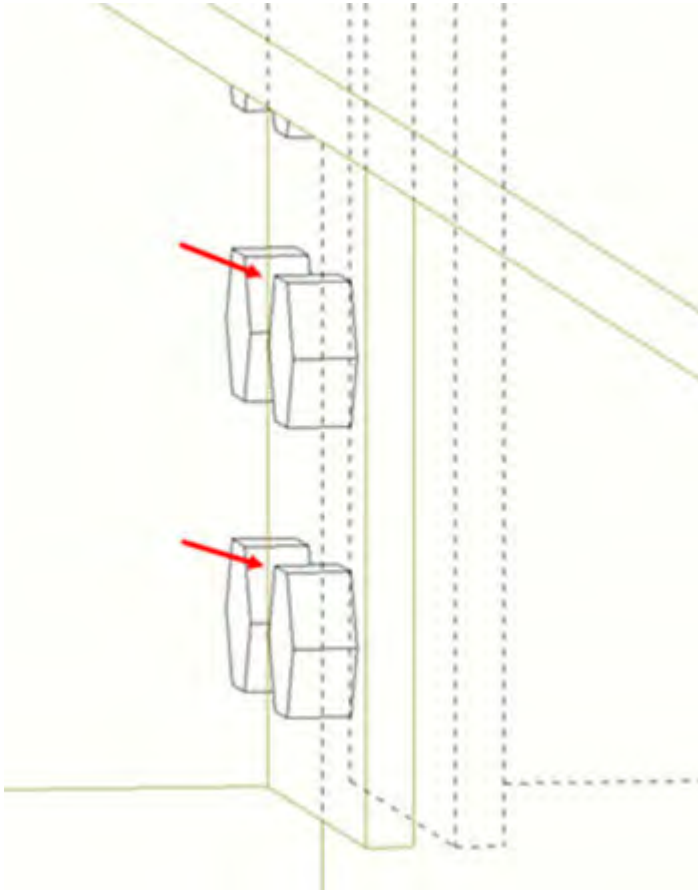

9.15 XS_HIDE_OTHER_PARTS_IN_ASSEMBLY_AND_CAST_UNIT_VIEWS

Category

Model View

Defines whether parts that do not belong to assemblies and cast units are shown or hidden in assembly and cast unit views. The default value `TRUE` hides the parts that do not belong to the selected assembly or cast unit. If you set this advanced option to `FALSE`, the parts are not hidden.

This advanced option is user specific and the setting is saved in `options.bin` under the user folder, for example, in `C:\Users\\AppData\Local\Trimble\Tekla Structures\\UserSettings`. Restart Tekla Structures to activate the new value.

9.16 XS_HIDE_WORKAREA

Category: Model View

Set this advanced option to `TRUE` to hide the work area or to `FALSE` to display the work area in model views. The default is `FALSE`. Redraw the views for the change to take effect.

This advanced option is user specific and the setting is saved in `options.bin` under the user folder, for example, in `C:\Users\\AppData\Local\Trimble\Tekla Structures\\UserSettings`. Restart Tekla Structures to activate the new value.

Example

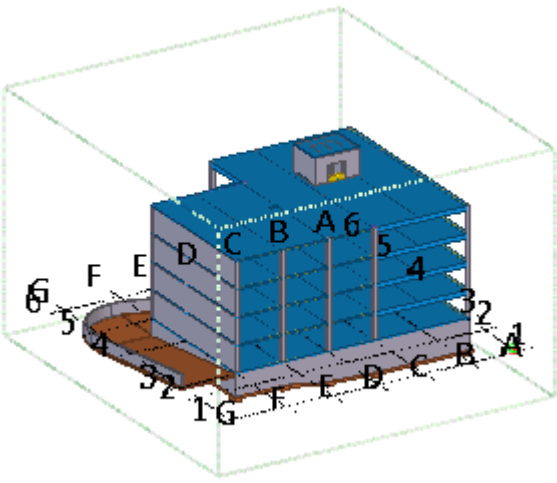
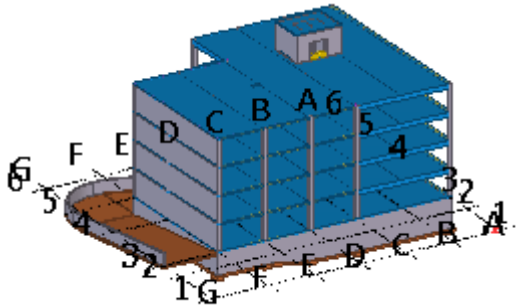
| Setting | Appearance in model |
|---------|--|
| FALSE |  A 3D perspective view of a multi-story building model. The model is enclosed within a green wireframe rectangular box, representing the work area. The building has a blue roof and grey walls. Grid lines are visible on the top and bottom surfaces, labeled with letters A through G and numbers 1 through 6. |
| TRUE |  The same 3D perspective view of the building model as above, but the green wireframe rectangular box is no longer visible, indicating that the work area has been hidden. |

TIP To temporarily hide the green work area box, hold down the **Ctrl** and **Shift** keys simultaneously, right-click and select **Redraw View**. To make the box visible again, right-click and select **Redraw View** again.

9.17 XS_HIGHLIGHT_ASSOCIATIVE_DIMENSION_CHANGES

Category

Dimensioning: General

Use to define whether changed dimension text and moved dimension points are highlighted in associative drawings.

When set to `TRUE` (default), Tekla Structures highlights the changed dimension text and the moved dimension points in updated associative drawings.

Tekla Structures highlights the changes in the following ways:

- A change symbol (by default a cloud) is drawn around the old point, the new point and the dimension values. It is displayed only when you select the dimension.
- An arrow is drawn from the old point to the new point.

This advanced option is user specific and the setting is saved in `options.bin` under the user folder, for example, in `C:\Users\\AppData\Local\Trimble\Tekla Structures\\UserSettings`. Restart Tekla Structures to activate the new value.

See also

[XS_HIGHLIGHT_MARK_CONTENT_CHANGES](#) (page 258)

[XS_ASSOCIATIVE_CHANGE_HIGHLIGHT_SYMBOL](#) (page 59)

[XS_ASSOCIATIVE_CHANGE_HIGHLIGHT_SIZE](#) (page 59)

9.18 XS_HIGHLIGHT_MARK_CONTENT_CHANGES

Category

Marking: General

Use to define whether changed mark contents are highlighted in associative drawings.

When set to `TRUE` (default), Tekla Structures highlights the mark contents that have been changed in updated associative drawings by drawing a change symbol (by default a cloud) around the changed mark content.

This advanced option is user specific and the setting is saved in `options.bin` under the user folder, for example, in `C:\Users\\AppData\Local\Trimble\Tekla Structures\\UserSettings`. Restart Tekla Structures to activate the new value.

See also

[XS_HIGHLIGHT_ASSOCIATIVE_DIMENSION_CHANGES](#) (page 258)

[XS_ASSOCIATIVE_CHANGE_HIGHLIGHT_SYMBOL](#) (page 59)

[XS_ASSOCIATIVE_CHANGE_HIGHLIGHT_SIZE](#) (page 59)

9.19 XS_HOLE_MARK_STRING_FOR_SIZE

Category

Marking: Bolts

Use to define the contents of the **Size** element in hole marks. The default value is `%BOLT_NUMBER%*D%HOLE.DIAMETER%`.

This advanced option is only used when there is a hole, no bolt (and the hole is a normal one).

The advanced options `XS_SHOP_HOLE_MARK_STRING_FOR_SIZE` and `XS_SITE_HOLE_MARK_STRING_FOR_SIZE` override this setting.

You can use any combination of text and the following options as the value for this advanced option. You can use the options in any order, and make calculations.

- BOLT_NUMBER
- DIAMETER
- LENGTH
- HOLE.DIAMETER
- LONG_HOLE_X
- LONG_HOLE_Y
- LONGHOLE_MIN (the shorter of the slotted hole dimensions)
- LONGHOLE_MAX (the longer of the slotted hole dimensions)
- BOLT_STANDARD
- BOLT_MATERIAL
- BOLT_ASSEMBLY_TYPE
- BOLT_COUNTERSUNK
- BOLT_SHORT_NAME
- BOLT_FULL_NAME

Enclose each option in % characters.

Note that if you are defining this advanced option in an `.ini` file, use double percent signs around the options. For example, `%%BOLT_NUMBER%%*D%%
%HOLE.DIAMETER%`.

To use special characters, enter a backslash (\) followed by an ASCII number.

With length-type options, but not in calculations, you can specify the number of decimals. For example, `HOLE.DIAMETER.2` shows (tapped) hole diameters with two decimals.

This advanced option is model specific and the setting is saved in the options database.

See also

[XS_SITE_HOLE_MARK_STRING_FOR_SIZE \(page 434\)](#)

[XS_SHOP_HOLE_MARK_STRING_FOR_SIZE \(page 407\)](#)

9.20 XS_HOLE_MARK_STRING_FOR_SIZE_IN_GA

Category

Marking: Bolts

Use to define the contents of the size element in bolt marks in general arrangement drawings. If you have not set the advanced options `XS_SHOP_HOLE_MARK_STRING_FOR_SIZE_IN_GA` or `XS_SITE_HOLE_MARK_STRING_FOR_SIZE_IN_GA`, then this advanced option is used.

This advanced option is only used when there is a hole, no bolt (and the hole is a normal one).

You can use any combination of text and the following options as the value for this advanced option. You can use the options in any order, and make calculations.

- BOLT_NUMBER
- DIAMETER
- LENGTH
- HOLE.DIAMETER
- LONG_HOLE_X
- LONG_HOLE_Y
- LONGHOLE_MIN (the shorter of the slotted hole dimensions)
- LONGHOLE_MAX (the longer of the slotted hole dimensions)
- BOLT_STANDARD

- BOLT_MATERIAL
- BOLT_ASSEMBLY_TYPE
- BOLT_COUNTERSUNK
- BOLT_SHORT_NAME
- BOLT_FULL_NAME

Enclose each option in % characters.

Note that if you are defining this advanced option in an `.ini` file, use double percent signs around the options. For example, `%%BOLT_NUMBER%%*D%
%HOLE.DIAMETER%%`.

To use special characters, enter a backslash (\) followed by an ASCII number.

With length-type options, but not in calculations, you can specify the number of decimals. For example, `HOLE.DIAMETER.2` shows (tapped) hole diameters with two decimals.

This advanced option is model specific and the setting is saved in the options database.

See also

[XS_SHOP_HOLE_MARK_STRING_FOR_SIZE_IN_GA \(page 409\)](#)

[XS_SITE_HOLE_MARK_STRING_FOR_SIZE_IN_GA \(page 435\)](#)

10 Advanced options - I

10.1 XS_IGNORE_CUT_VALUE_IN_TEMPLATE

This advanced option must be set in an initialization (.ini) file.

By default, when a Template Editor template output value field does not fit into a cell, three asterisks (***) will indicate that the value is cut. For example, when a template has a value field length limited to 10 characters and the output value is 11 characters or more, *** will be displayed at the end of the value.

If you do not want to display the asterisks, set `XS_IGNORE_CUT_VALUE_IN_TEMPLATE` to `TRUE`.

10.2 XS_IGNORE_CROSSBAR_LOCATION_IN_REBAR_MESH_NUMBERING

Category: Numbering

Use this advanced option to define whether the location of the crossing bars (e.g. above or below the main bars) is ignored in the numbering of reinforcement meshes.

The default value is `FALSE`.

If `XS_IGNORE_CROSSBAR_LOCATION_IN_REBAR_MESH_NUMBERING` is set to `FALSE`, the location of the crossing bars affects numbering, and the otherwise identical meshes receive different numbers if the crossing bars are on the different sides of the main bars.

If `XS_IGNORE_CROSSBAR_LOCATION_IN_REBAR_MESH_NUMBERING` is set to `TRUE`, crossing bars can be on either side of the main bars, and the otherwise identical meshes still receive the same number.

This advanced option is model specific and the setting is saved in the options database.

NOTE We do not recommend that you change this setting during a project. If you do so, you must carry out full numbering (**File --> Diagnose & repair --> Diagnose and repair numbering: all**).

10.3 XS_IGNORE_SUBASSEMBLY_HIERARCHY_IN_DIMENSIONING

Category

Dimensioning: Parts

Use to define whether sub-assembly parts are dimensioned as secondary parts of the main assembly.

When set to `TRUE`, Tekla Structures ignores sub-assemblies, and parts inside the sub-assemblies are dimensioned as if they were parts in the main assembly. The default value is `FALSE`.

This advanced option is model specific and the setting is saved in the options database.

10.4 XS_IFC_EXPORT_OBJECT_LAYER_FROM_UDA

This advanced option must be set in an initialization (.ini) file.

Use this advanced option to define for the IFC2x3 export the layer name of an object in an IFC file using a predefined UDA. Using this advanced option requires that you have selected the option **Layer names as part names** in the IFC2x3 export settings. By default, the value is empty, and the part name is used as the layer name.

The UDA name is case sensitive, so you need to check how the UDA name is written in the `objects.inp` file. By default, the `objects.inp` file is located in `C:\ProgramData\Tekla Structures\Work\Environments\common\inp`.

Enter the following in an `.ini` file:

```
set XS_IFC_EXPORT_OBJECT_LAYER_FROM_UDA=<UDA>
```

Replace the `<UDA>` with the UDA of your choice.

Example: The UDA input field "Fabricator name" is defined as "fabricator" in `objects.inp`, so enter the UDA as follows:

```
set XS_IFC_EXPORT_OBJECT_LAYER_FROM_UDA=fabricator
```

10.5 XS_IFC2X3_EXPORT_SECONDARY_AS_DISCRETEACCESSORY

This advanced option must be set in an initialization (.ini) file.

The IFC2x3 export does not export steel secondary objects as `IfcDiscreteAccessory`. You can force steel secondary objects to the `IfcDiscreteAccessory` category by setting this advanced option to `TRUE` in an `.ini` file, for example, in `teklastructures.ini`.

10.6 XS_IMPERIAL

Category

Imperial Units

Set this advanced option to `TRUE` to have output in imperial units only. If you do not want to do this, set it to `FALSE` (default).

This affects only the following elements of bolt marks:

- Gage of outstanding leg (GOL)
- Center-to-center distance

This advanced option is model specific and the setting is saved in the options database.

10.7 XS_IMPERIAL_DATE

Category

Imperial units

Set this advanced option to `TRUE` to use the date format `mm/dd/yyyy`. Set it to `FALSE` (default) to use the date format `dd.mm.yyyy`.

This advanced option is user specific and the setting is saved in `options.bin` under the user folder, for example, in `C:\Users\<user>\AppData\Local`

\Trimble\Tekla Structures\\UserSettings. Restart Tekla Structures to activate the new value.

10.8 XS_IMPERIAL_INPUT

Category

Imperial Units

Set this advanced option to `TRUE` to allow input in imperial units only. To disable the advanced option, set it to `FALSE` (default).

This advanced option is model specific and the setting is saved in the options database.

10.9 XS_IMPERIAL_TIME

Category

Imperial Units

Set this advanced option to `TRUE` to use the time format `hh:mm:ss am/pm`.

Set to `FALSE` to use the time format `hh:mm:ss`.

This advanced option is user specific and the setting is saved in `options.bin` under the user folder, for example, in `C:\Users\\AppData\Local\Trimble\Tekla Structures\\UserSettings`. Restart Tekla Structures to activate the new value.

10.10 XS_IMPERIAL_TRIANGLES

Category

Imperial Units

Set this advanced option to `TRUE` to also show triangle ratios in inches.

The default value is `FALSE`.

This advanced option is model specific and the setting is saved in the options database.

10.11 XS_IMPORT_DWG_TEXT_AS_POLYGON

Category: Drawing Properties

This advanced option can be used when adding DWG files to drawings. If you have problems with fonts in DWG files, set this advanced option to `TRUE`, and Tekla Structures will import fonts as polygons, instead of fonts. By default, the option is set to `FALSE`.

This advanced option is user specific, and the setting is saved in `options.bin` under the user folder.

10.12 XS_IMPORT_MODEL_LOG

Category

Import

Set to `TRUE` to create a log every time you use an import model.

Set to `APPEND` to append a log entry to the previous log.

This advanced option is user specific and the setting is saved in `options.bin` under the user folder, for example, in `C:\Users\\AppData\Local\Trimble\Tekla Structures\\UserSettings`. Restart Tekla Structures to activate the new value.

10.13 XS_INCH_SIGN_ALWAYS

Category

Imperial Units

By default, Tekla Structures does not put an inch symbol (") in dimensions which contain only inches. Set this advanced option to `TRUE` to show inch symbols in all dimensions. The default value is `FALSE`.

This advanced option is model specific and the setting is saved in the options database.

10.14 XS_INCLUDE_DWG_ATTRIBUTES_IN_REPORTS_AND_INQUIRE

Category

Speed and Accuracy

DWG-specific attributes are now available in reports and inquiries only if this advanced option is set to `TRUE`. This advanced option is by default set to `FALSE`.

This advanced option is role specific. When the type **SYSTEM(ROLE)** is in use, the default value is used. When the type **MODEL(ROLE)** or **DRAWING(ROLE)** is in use, you can change the value, which is then the same for all users in the current model.

10.15 XS_INHERIT_CONCRETE_PART_NUMBERING_SETTINGS_FROM_CAST_UNIT

Category: Numbering

Use this advanced option to define whether to set concrete part numbering according to cast unit numbering settings. If you set this advanced option to `TRUE` (default), the part number prefix for concrete parts includes the cast unit prefix and the start number. If you set the advanced option to `FALSE`, the cast unit prefix and the start number are not included.

For example, the cast unit prefix is `C` and the start number is `100`. When the advanced option is `TRUE`, the concrete part prefix is `Concrete_C-100`. When the advanced option is `FALSE`, the prefix is only `Concrete`.

This setting affects concrete parts: Strip and pad footings, concrete beams and columns, concrete walls and slabs, and concrete polybeams.

This advanced option is model specific and the setting is saved in the options database.

See also

[XS_CONCRETE_PART_NUMBERING_PREFIX](#) (page 100)

[XS_CONCRETE_PART_NUMBERING_START_NUMBER](#) (page 101)

10.16 XS_INP

This advanced option is system specific and is read from `teklastructures.ini`. It can also be set locally, see your environment `.ini`

file (env_<environment_name>.ini). Generally, there is no need to modify system-specific settings. Do not modify them if you are not an administrator.

Several system files are read from this folder, such as definitions for parametric profiles (.clb), IFC property set configurations (.xml), line type mappings (.lin), global UDA definitions (objects.inp), and access rights (privileges.inp).

The default location is XSDATADIR%\environments\common\inp\. You can use semicolon-separated lists of folder paths.

10.17 XS_INTELLIGENCE_DO_NOT_REMOVE_OBSOLETE_VIEWS

Category

Drawing Properties

Enter **TRUE** in the **Value** field to prevent drawing views from being deleted when associated objects are removed from the model. **FALSE** is the default.

This advanced option is role specific. When the type **SYSTEM(ROLE)** is in use, the default value is used. When the type **MODEL(ROLE)** or **DRAWING(ROLE)** is in use, you can change the value, which is then the same for all users in the current model.

For general arrangement drawings use the advanced option
XS_INTELLIGENCE_DO_NOT_REMOVE_OBSOLETE_VIEWS_IN_GA.

See also

[XS_INTELLIGENCE_DO_NOT_REMOVE_OBSOLETE_VIEWS_IN_GA \(page 268\)](#)

10.18 XS_INTELLIGENCE_DO_NOT_REMOVE_OBSOLETE_VIEWS_IN_GA

Category

Drawing Properties

Enter **TRUE** (default) to prevent drawing views from being deleted when associated objects are removed from the model.

This advanced option is role specific. When the type **SYSTEM(ROLE)** is in use, the default value is used. When the type **MODEL(ROLE)** or **DRAWING(ROLE)** is in use, you can change the value, which is then the same for all users in the current model.

See also

[XS_INTELLIGENCE_DO_NOT_REMOVE_OBSOLETE_VIEWS](#) (page 268)

10.19 XS_INTELLIGENCE_MAX_PART_COUNT

Category: Drawing properties

Enter an integer to define how many parts are taken into account when searching for associated objects. The advanced option is set to 20 by default.

This advanced option is model specific and the setting is saved in the options database.

10.20 XS_INTELLIGENCE_MAX_PLANE_COUNT

Category: Drawing properties

Enter an integer to define how many planes are taken into account when searching for associated objects. The advanced option is set to 1000 by default.

This advanced option is model specific and the setting is saved in the options database.

10.21 XS_INTELLIGENCE_MAX_RULE_COUNT

Category: Drawing Properties

Use to decrease the number of associative rules that are used for one measurement point. A smaller value, for example 10 (default), is usually enough. A smaller value may also increase performance and decrease the database size.

This advanced option also controls the maximum number of shown rules in the dimension associativity rule list.

This advanced option is role specific. When the type **SYSTEM(ROLE)** is in use, the default value is used. When the type **MODEL(ROLE)** or **DRAWING(ROLE)** is in use, you can change the value, which is then the same for all users in the current model.

WARNING Use this advanced option only when there are performance issues with associative drawings. Using this advanced option may

cause losing of associativity in some cases when objects have been deleted from the model.

10.22 XS_INTELLIGENT_CLONING_ADD_DIMENSIONS

Category

Drawing Properties

Set to `TRUE` to create dimensions for additional parts using automatic dimensioning during cloning, and to `FALSE` to prevent this. The default is `TRUE`.

This advanced option is model specific and the setting is saved in the options database.

10.23 XS_INTELLIGENT_DRAWING_ALLOWED

Category

Drawing Properties

Clear the value or set it to `FALSE` to prevent Tekla Structures from automatically moving dimensions, marks, etc. according to model changes. `TRUE` is the default value.

This advanced option is model specific and the setting is saved in the options database.

To control how the drawing view placing works when the model changes, set this advanced option to `TRUE` and use it together with the advanced option `XS_DRAWING_UPDATE_VIEW_PLACING`.

NOTE This setting affects all drawings. To prevent Tekla Structures from automatically updating general arrangement drawings, use the advanced option `XS_INTELLIGENT_DRAWING_ALLOWED_IN_GA`.

See also

[XS_INTELLIGENT_DRAWING_ALLOWED_IN_GA \(page 270\)](#)

[XS_DRAWING_UPDATE_VIEW_PLACING \(page 200\)](#)

10.24 XS_INTELLIGENT_DRAWING_ALLOWED_IN_GA

Category

Drawing Properties

Clear the value or set the advanced option to `FALSE` to prevent Tekla Structures from automatically moving dimensions, marks, etc. according to model changes.

This advanced option is model specific and the setting is saved in the options database.

NOTE This setting affects only general arrangement drawings. To prevent Tekla Structures from automatically updating all types of drawings, use the advanced option `XS_INTELLIGENT_DRAWING_ALLOWED`.

See also

[XS_INTELLIGENT_DRAWING_ALLOWED \(page 270\)](#)

10.25 XS_INTELLIGENT_MESSAGES_ALLOWED

Category

Drawing Properties

Set this advanced option to `TRUE` to display message when a drawing is opened if a model object to which one or more drawing objects are linked is deleted from the model.

If you do not want to display the message, set this advanced option to `FALSE` (default).

This advanced option is user specific and the setting is saved in `options.bin` under the user folder, for example, in `C:\Users\<user>\AppData\Local\Trimble\Tekla Structures\<version>\UserSettings`. Restart Tekla Structures to activate the new value.

10.26 XS_INTELLIGENT_UPDATE_ADD_DIMENSIONS

Category

Drawing Properties

Set to `TRUE` to add dimensions for new parts, bolts and reinforcing bars when updating drawings and to `FALSE` to prevent this. The default is `TRUE`.

This advanced option is model specific and the setting is saved in the options database.

10.27 XS_INVALID_POUR_BREAK_COLOR

This advanced option must be set in an initialization (.ini) file.

Use this advanced option to change the color of invalid pour breaks in model views. Enter number as the value using the class numbers in the part properties in the property pane to indicate the color. For example, if you set this advanced option to 6, Tekla Structures will color all invalid pour breaks yellow. The default value is 58 (red).

10.28 XS_I_PROFILE_CENTER

Category: Dimensioning - parts

Set to `NONE` to prevent Tekla Structures from using the center line of I profiles to dimension front views. By default, no value is set.

This advanced option is model specific and the setting is saved in the options database.

10.29 XS_ISO_LEG_LENGTH_AS_WELDSIZE

Category: Welds

When [XS_AISC_WELD_MARK \(page 42\)](#) is set to `FALSE`, set `XS_ISO_LEG_LENGTH_AS_WELDSIZE` to:

- `TRUE` to use the weld size as the leg length (z) of the fillet welds.
- `FALSE` to use the weld size as the throat thickness (a) of the fillet welds.

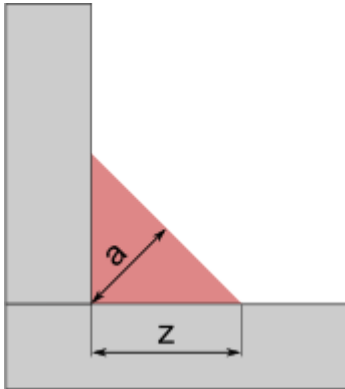

NOTE The weld prefix overrides the setting of the advanced option `XS_ISO_LEG_LENGTH_AS_WELDSIZE`. If you have set the prefix of a weld to `a`, the weld size determines the design throat thickness. When the weld prefix is `z`, the weld size determines the leg length.

If the last character of the weld prefix is `s`, Tekla Structures creates the solid weld object so that `a` equals weld size.

This advanced option is model specific and the setting is saved in the options database.

After changing this setting, modify existing welds or their properties to activate the new setting and to update the weld solids.

11 Advanced options - J

11.1 XS_JOINT_NUMBER_FORMAT

Category

Marking: General

The connection numbers are visible in drawings, when you set the **Connection mark** field to **Number** in the **Connection mark properties** dialog box. Use this advanced option to define the connection number format. For example, you can use it to define prefix text.

This advanced option is model specific and the setting is saved in the options database.

Example

In `XS_JOINT_NUMBER_FORMAT=J%3.3d`:

- J is the prefix.
The rest of the string defines the number format.
- The first number defines the minimum field width.
- The second number defines the minimum quantity of numbers to display.
- % and d (integer value) indicate the format.

11.2 XS_JOINTS_USE_NOTCH1

Category

Components

Set to 1 to have connections use standard notch routines. This is the default value.

Set to 0 to have connections use simple notch routines.

This advanced option is model specific and the setting is saved in the options database.

12 Advanced options - K

12.1 XS_KEEP_AUTOSAVE_FILES_ON_EXIT_WHEN_NOT_SAVING

Category

Modeling Properties

Tekla Structures deletes autosave files when you close a model to save disk space. If this advanced option is set to `TRUE`, Tekla Structures does not delete these files, even if you exit Tekla Structures without saving the model. The default value is `TRUE`.

This advanced option is user specific and the setting is saved in `options.bin` under the user folder, for example, in `C:\Users\\AppData\Local\Trimble\Tekla Structures\\UserSettings`. Restart Tekla Structures to activate the new value.

12.2 XS_KEYIN_ABSOLUTE_PREFIX

Category: Modeling Properties

Defines the character used in absolute snapping. Enter any allowed ASCII character. The default value is `$`.

If you have set Tekla Structures to use absolute snapping by default using the advanced option `XS_KEYIN_DEFAULT_MODE`, you do not need to use a snap character for absolute snapping.

This advanced option is user specific and the setting is saved in `options.bin` under the user folder, for example, in `C:\Users\\AppData\Local\Trimble\Tekla Structures\\UserSettings`. Restart Tekla Structures to activate the new value.

See also

[XS_KEYIN_DEFAULT_MODE \(page 277\)](#)

[XS_KEYIN_RELATIVE_PREFIX \(page 278\)](#)

[XS_KEYIN_GLOBAL_PREFIX \(page 277\)](#)

12.3 XS_KEYIN_DEFAULT_MODE

Category: Modeling Properties

Defines the snapping mode Tekla Structures uses by default. Set to `RELATIVE` (default), `ABSOLUTE`, or `GLOBAL`.

In the relative snapping mode, the coordinates you enter in the **Enter a Numeric Location** dialog box as such without any prefix are relative to the last position picked.

In the absolute snapping mode, the coordinates are based on the origin of the work plane.

In the global snapping mode, the coordinates are based on the global origin and the global x and y directions.

This advanced option is user specific and the setting is saved in `options.bin` under the user folder, for example, in `C:\Users\\AppData\Local\Trimble\Tekla Structures\\UserSettings`. Restart Tekla Structures to activate the new value.

See also

[XS_KEYIN_RELATIVE_PREFIX \(page 278\)](#)

[XS_KEYIN_ABSOLUTE_PREFIX \(page 276\)](#)

[XS_KEYIN_GLOBAL_PREFIX \(page 277\)](#)

12.4 XS_KEYIN_GLOBAL_PREFIX

Category: Modeling Properties

Defines the character used in global snapping. The default value is `!`.

If you have set Tekla Structures to use global snapping by default using the advanced option `XS_KEYIN_DEFAULT_MODE`, you do not need to use a snap character for global snapping.

This advanced option is user specific and the setting is saved in `options.bin` under the user folder, for example, in `C:\Users\\AppData\Local`

\Trimble\Tekla Structures\\UserSettings. Restart Tekla Structures to activate the new value.

See also

[XS_KEYIN_DEFAULT_MODE \(page 277\)](#)

[XS_KEYIN_RELATIVE_PREFIX \(page 278\)](#)

[XS_KEYIN_ABSOLUTE_PREFIX \(page 276\)](#)

12.5 XS_KEYIN_RELATIVE_PREFIX

Category: Modeling Properties

Defines the character used in relative snapping. Enter any allowed ASCII character. The default value is @.

If you have set Tekla Structures to use relative snapping by default using the advanced option `XS_KEYIN_DEFAULT_MODE`, you do not need to use a snap character for relative snapping.

This advanced option is user specific and the setting is saved in `options.bin` under the user folder, for example, in `C:\Users\\AppData\Local\Trimble\Tekla Structures\\UserSettings`. Restart Tekla Structures to activate the new value.

See also

[XS_KEYIN_DEFAULT_MODE \(page 277\)](#)

[XS_KEYIN_ABSOLUTE_PREFIX \(page 276\)](#)

[XS_KEYIN_GLOBAL_PREFIX \(page 277\)](#)

12.6 XS_KNOCK_OFF_DIMENSION_PRECISION

Category: Dimensioning - general

Set this advanced option to 16 or 32 to set the precision of the knock-off dimensions to 1/16 or 1/32. Otherwise the precision is the one that is set in the dimensioning dialog box. The default value is zero. Other values are ignored, and the knock-off dimension precision is the same as that for other dimensions.

Knock-off dimensions are used in integrated dimensioning.

13 Advanced options - L

13.1 XS_LANGUAGE

This advanced option must be set in an initialization (.ini) file.

This advanced option is system specific and is read from environment files. Generally, there is no need to modify system-specific settings. Do not modify them if you are not an administrator.

This advanced option sets the Tekla Structures default language. The default language is displayed first when you go to the **File** menu and click **Settings** --> **Change language** .

13.2 XS_LEADER_LINE_TO_DRAGGED_DIMENSION_TEXT

Category: Dimensioning: General

When you set this advanced option to `TRUE`, a leader line is drawn when a dimension text is dragged away from the dimension line. When you set it to `FALSE`, the leader line is not drawn. The default value is `TRUE`.

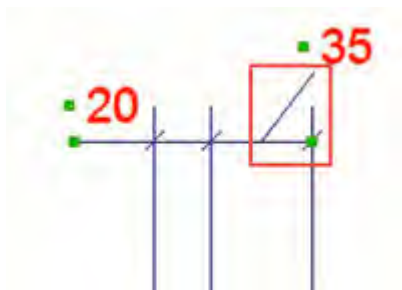

This advanced option is model specific and the setting is saved in the options database.

13.3 XS_LICENSE_SERVER_HOST

This advanced option must be set in an initialization (.ini) file.

With this advanced option, the administrator can predefine the address of the license server for the user, so that the user does not need to make the selection and enter the server details in the licensing dialog box at the first start of the Tekla Structures software.

You can add this advanced option in a customized `.ini` file and use it in start-up shortcuts for starting `teklastructures.exe` with the initialization that you have customized, for example.

For Tekla Structures subscriptions, enter `https` as the value.

Example

```
set XS_LICENSE_SERVER_HOST=https
```

For legacy on-premises licensing, enter the advanced option value in one of the following formats:

```
port@host
```

```
port@ip-address
```

Example

```
set XS_LICENSE_SERVER_HOST=27007@MY_LICENSE_SERVER_NAME
```

13.4 XS_LOAD_MODELING_CODE

This advanced option must be set in an initialization (.ini) file. For more information about initialization files, see .

Use this advanced option for defining the set of load group types. Load combinations are generated according to rules that are specific to the load modeling code. The default value is `EuroCode`.

Possible values are: `EuroCode`, `AISC`, `UBC`, `IBC`, `ACI`, `BS`, `CM66 (F)`, and `BAEL91 (F)`.

Example

```
set XS_LOAD_MODELING_CODE=EuroCode
```

13.5 XS_LOG_FILE_NAME

Category

This advanced option must be set in an initialization (.ini) file.

This advanced option is system specific and is read from environment files. Generally, there is no need to modify system-specific settings. Do not modify them if you are not an administrator.

This advanced option defines the name of the Tekla Structures log file. The default value is `TeklaStructures.log`.

13.6 XS_LOG_LEVEL

Category: Speed and accuracy

Use this advanced option to define which messages Tekla Structures writes to the session history log file, `TeklaStructures_<user>.log`. Set the level of the log output to one of the following options:

- `DEBUG`: all log messages are written
- `INFO`: all log messages except debug messages are written
- `WARNING`: all log messages except debug and info messages are written
- `ERROR`: only error and assert messages are written

The default value is `INFO`. Providing any value other than one of the above results in log level `INFO`.

This advanced option is system specific and is read from `teklastructures.ini`. Generally, there is no need to modify system-specific settings. Do not modify them if you are not an administrator.

13.7 XS_LOG_TIMER

Category: Speed and accuracy

Set this advanced option to `TRUE` to save loading and opening times in the session history log. The default value is `FALSE`. Using this advanced option you can get a quick performance overview directly from the log.

Examples of log entries:

Plug-ins loaded in 1233ms.

Plug-in dialogs loaded in 1235ms.

Opening model...

.Inp files loaded in 355ms.

Model db read in 3467ms.

Searchtree intialized in 10400ms.

Model opened in 354258743ms.

This advanced option is system specific and is read from environment files. Generally, there is no need to modify system-specific settings. Do not modify them if you are not an administrator.

13.8 XS_LOGPATH

Category

This advanced option must be set in an initialization (.ini) file.

This advanced option points to the folder that contains the Tekla Structures log file.

This advanced option is system specific and is read from environment files. Generally, there is no need to modify system-specific settings. Do not modify them if you are not an administrator.

13.9 XS_LONGHOLE_MARK_STRING_FOR_SIZE

Category: Marking - bolts

Use to define the contents of the **Size** element in slotted hole marks. For example, enter `%BOLT_NUMBER%*D%HOLE.DIAMETER% (%HOLE.DIAMETER+LONGHOLE_MIN%x%HOLE.DIAMETER+LONGHOLE_MAX%)`.

This advanced option is only used when there is a slotted hole.

The advanced options `XS_SHOP_LONGHOLE_MARK_STRING_FOR_SIZE` and `XS_SITE_LONGHOLE_MARK_STRING_FOR_SIZE` override this setting.

You can use any combination of text and the following options as the value for this advanced option. You can use the options in any order, and make calculations.

- BOLT_NUMBER
- DIAMETER
- LENGTH

- HOLE.DIAMETER
- LONG_HOLE_X
- LONG_HOLE_Y
- LONGHOLE_MIN (the shorter of the slotted hole dimensions)
- LONGHOLE_MAX (the longer of the slotted hole dimensions)
- BOLT_STANDARD
- BOLT_MATERIAL
- BOLT_ASSEMBLY_TYPE
- BOLT_COUNTERSUNK
- BOLT_SHORT_NAME
- BOLT_FULL_NAME

Enclose each option in % characters.

Note that if you are defining this advanced option in an `.ini` file, use double percent signs around the options. For example, `%%BOLT_NUMBER%%*D%
%HOLE.DIAMETER%%`.

To use special characters, enter a backslash (\) followed by an ASCII number.

With length-type options, but not in calculations, you can specify the number of decimals. For example, `HOLE.DIAMETER.2` shows (tapped) hole diameters with two decimals.

This advanced option is model specific and the setting is saved in the options database.

See also

[XS_SITE_LONGHOLE_MARK_STRING_FOR_SIZE](#) (page 436)

[XS_SHOP_LONGHOLE_MARK_STRING_FOR_SIZE](#) (page 410)

13.10 XS_LONGHOLE_MARK_STRING_FOR_SIZE_IN_GA

Category: Marking - bolts

Use to define the contents of the size element in slotted hole marks in general arrangement drawings. If you have not set the advanced option

`XS_SHOP_LONGHOLE_MARK_STRING_FOR_SIZE_IN_GA` or `XS_SITE_LONGHOLE_MARK_STRING_FOR_SIZE_IN_GA`, then this advanced option is used.

This advanced option is only used when there is a slotted hole.

You can use any combination of text and the following options as the value for this advanced option. You can use the options in any order, and make calculations.

- BOLT_NUMBER
- DIAMETER
- LENGTH
- HOLE.DIAMETER
- LONG_HOLE_X
- LONG_HOLE_Y
- LONGHOLE_MIN (the shorter of the slotted hole dimensions)
- LONGHOLE_MAX (the longer of the slotted hole dimensions)
- BOLT_STANDARD
- BOLT_MATERIAL
- BOLT_ASSEMBLY_TYPE
- BOLT_COUNTERSUNK
- BOLT_SHORT_NAME
- BOLT_FULL_NAME

Enclose each option in % characters.

Note that if you are defining this advanced option in an `.ini` file, use double percent signs around the options. For example, `%%BOLT_NUMBER%%*D%
%HOLE.DIAMETER%%`.

To use special characters, enter a backslash (\) followed by an ASCII number.

With length-type options, but not in calculations, you can specify the number of decimals. For example, `HOLE.DIAMETER.2` shows (tapped) hole diameters with two decimals.

This advanced option is model specific and the setting is saved in the options database.

See also

[XS_SHOP_LONGHOLE_MARK_STRING_FOR_SIZE_IN_GA \(page 411\)](#)

[XS_SITE_LONGHOLE_MARK_STRING_FOR_SIZE_IN_GA \(page 437\)](#)

14 Advanced options - M

14.1 XS_MACRO_DIRECTORY

Specifies a global folder and one or more local folders for recorded macro files.

Category: File Locations

Macro files are usually specific to the language and environment, and do not run in any other environment or language. This advanced option is system-specific.

First define the global folder, then the local folders. Use a semicolon (;) as the separator between paths.

For example:

```
set XS_MACRO_DIRECTORY=%XSDATADIR%environments\common\macros;%XSDATADIR%environments\uk\General\user-macros
```

By default, this advanced option is set to `..\ProgramData\Trimble\Tekla Structures\<version>\environments\common\macros`.

NOTE Do not change the global folder. If necessary, you can change the local folders.

When you click **Access advanced features** in **Applications & components**, you can select whether to create a global or local macro by selecting **New macro** --> **Local** or **New macro** --> **Global**. The **Local** option is only shown if you have specified a local folder.

NOTE The macro folder must contain the `modeling` and `drawings` subfolders.

14.2 XS_MACRO_ENABLE_TIMESTAMP

Category

Category: Modeling Properties

Set this advanced option to `TRUE` to examine the time spent on different tasks while recording macros. This advanced option is system-specific.

The default value is `FALSE`. If you change the value, you need to reopen the model to activate the new setting.

The timestamps are in the `.cs` file of the macro in question, which is located in `../environments/common/macros` folder. The macro is saved in the `drawings` or `modeling` folders, depending on in which mode the macro was recorded.

```
// Generated by Tekla.Technology.Akit.ScriptBuilder

namespace Tekla.Technology.Akit.Userscript
{
    public class script
    {
        public static void Run(Tekla.Technology.Akit.IScript akit)
        {
            akit.PushButton("RecordPB", "MacroSelector"); // 2012-12-05T09:15:14
            akit.ValueChange("ElementCatalogDialog", "txtFldSearch", "144"); // 2012-12-05T09:15:19
            akit.PushButton("butSearchButton", "ElementCatalogDialog"); // 2012-12-05T09:15:19
        }
    }
}
```

14.3 XS_MACRO_LOG

This advanced option must be set in an initialization (.ini) file.

By default Tekla Structures macro output is displayed in the terminal window. Set this advanced option to a file name to save this output to a file.

This advanced option is user specific and the setting is saved in `options.bin` under the user folder, for example, in `C:\Users\<user>\AppData\Local\Trimble\Tekla Structures\<version>\UserSettings`. Restart Tekla Structures to activate the new value.

14.4 XS_MACRO_REFERENCES

Category: Modeling properties

NOTE This advanced option is obsolete, and not used anymore by the macro engine. For macro scripting, use "#pragma reference" instead, either with absolute path, relative path, environment variables, or in the model folder.

This advanced option defines a path to an additional library that is used when a macro is compiled. The default path is:

```
;System.Windows.Forms;Tekla.Technology.Scripting;Tekla.Structures;Tekla.Structures.Model;Tekla.Structures.Drawing;MacroSelector;System.Drawing;System.Data;System.Xml;Tekla.DataSharing.CacheServiceClient;Tekla.DataSharing.SharedPublic.
```

This advanced option is system-specific.

14.5 XS_MAGNETIC_PLANE_OFFSET

Category

Components

Use to adjust the magnetic distance of magnetic planes. By default the distance is 0.2 mm.

Setting this advanced option does not affect magnetic construction lines.

This advanced option is model specific and the setting is saved in the options database.

14.6 XS_MARK_ALL_BOLT_GROUPS_SEPARATELY

Category

Marking: Bolts

Set this advanced option to `TRUE` to prevent Tekla Structures from combining bolt group marks. By default Tekla Structures combines bolt group marks (`FALSE`).

This advanced option is model specific and the setting is saved in the options database.

Example

In the image below, this advanced option is set to `TRUE`.

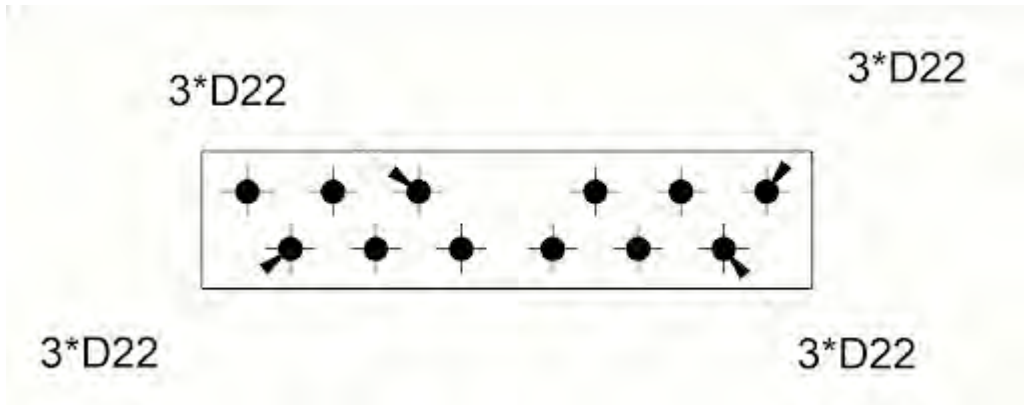

In the image below, FALSE is used.

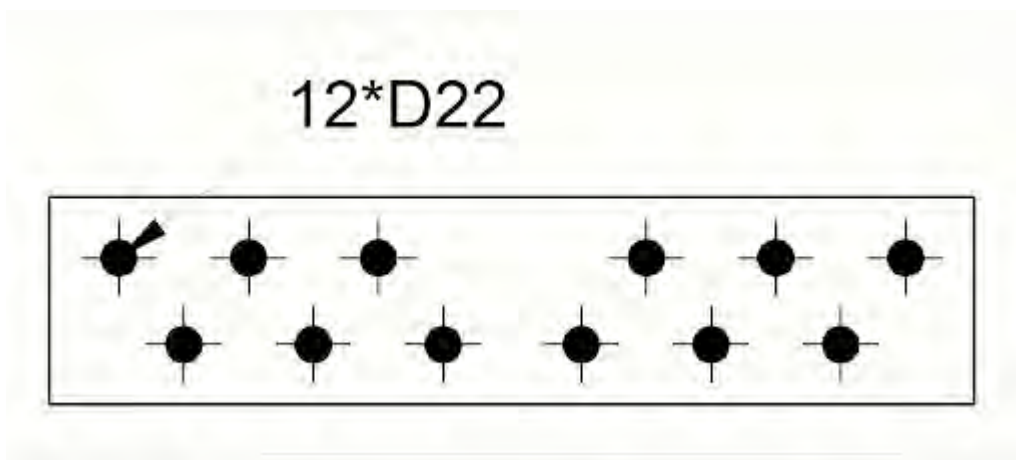

14.7 XS_MARK_ELEMENT_SPACE_FACTOR

Category

Marking: General

By default Tekla Structures leaves a space $0.3 \times \text{text height}$ between mark elements. Use this advanced option to change the default value.

This advanced option is model specific and the setting is saved in the options database.

Example

In the example below, the default value 0.3 was changed to 1.



14.8 XS_MARK_FONT

Category

Drawing Properties

You can set the mark text font (for part marks etc.) by giving the name of the font to this advanced option. The default value is Arial. If no font is given, Tekla Structures uses the default font defined for `XS_DEFAULT_FONT`.

This advanced option is model specific and the setting is saved in the options database.

See also

[XS_DEFAULT_FONT \(page 116\)](#)

14.9 XS_MARK_INTELLIGENT_PLACING

Category: Marking - general

Marks are automatically placed according to the mark placing algorithm if the advanced option `XS_MARK_INTELLIGENT_PLACING` is set to `TRUE` (default). The mark placement algorithm tries to avoid crossing leader lines, and also places marks otherwise more clearly.

If you select all four corner points in the **Part Mark Placing** dialog box, the automatic mark placement will be used, and Tekla Structures attempts to find the closest quarter with empty space.

The new algorithm applies to all marks and associative notes, except weld marks.

If `XS_MARK_INTELLIGENT_PLACING` is set to `FALSE`, you can still arrange marks and notes using the following commands:

- You can arrange the selected marks and notes so that you avoid crossing leader lines by using the **Arrange marks** command on the ribbon. The result also depends on the defined protection settings and search margins.

- With another ribbon command **Align marks** --> **Auto-align marks** you can align the selected marks and associative notes that are close by stacking the marks and placing them evenly.
- You can also align selected marks around a point using the command **Align marks** --> **Align to a point**. This command tries to avoid crossing leader lines.
- These commands can also be started from **Quick Launch**.

This advanced option is model specific and the setting is saved in the options database.

14.10 XS_MARK_INTELLIGENT_POST_FREEPLACE_NEARBY

Category:Marking - general

If you set the advanced option `XS_MARK_INTELLIGENT_POST_FREEPLACE_NEARBY` to `TRUE` (default), Tekla Structures first places the marks in drawings avoiding crossing leader lines, and after that runs the place nearby command, which ensures that the mark locations follow the protection settings. If you set this advanced option to `FALSE`, the crossing mark check is performed, but the place nearby command is not run, so some of the protection settings may not be followed.

Note that you need to set the advanced option `XS_TRY_TO_KEEP_LOCATION_IN_FREEPLACING` to `TRUE` (Default) for the advanced option `XS_MARK_INTELLIGENT_POST_FREEPLACE_NEARBY` to work.

This advanced option is model specific and the setting is saved in the options database.

See also

[XS_MARK_INTELLIGENT_PLACING](#) (page 289)

[XS_TRY_TO_KEEP_LOCATION_IN_FREEPLACING](#) (page 457)

14.11 XS_MARK_LEADER_LINE_ARROW_HEIGHT

Category

Marking: General

Height of arrow head in mark leader line. 1 is the default value. For example, the standard AutoCAD leader line arrow height is 0.67.

This advanced option is role specific. When the type **SYSTEM(ROLE)** is in use, the default value is used. When the type **MODEL(ROLE)** or **DRAWING(ROLE)** is in use, you can change the value, which is then the same for all users in the current model.

14.12 XS_MARK_LEADER_LINE_ARROW_LENGTH

Category

Marking: general

Length of arrow head in mark leader line. The default is 2.5.

This advanced option is role specific. When the type **SYSTEM(ROLE)** is in use, the default value is used. When the type **MODEL(ROLE)** or **DRAWING(ROLE)** is in use, you can change the value, which is then the same for all users in the current model.

14.13 XS_MARK_LEADER_LINE_EXTENSION_LENGTH

Category: Marking - general

Use to define the length of the leader line extension. The extension is placed before the start of a text string. Give the length in millimeters. The default value is 0.

This advanced option is role specific. When the type **SYSTEM(ROLE)** is in use, the default value is used. When the type **MODEL(ROLE)** or **DRAWING(ROLE)** is in use, you can change the value, which is then the same for all users in the current model.

14.14 XS_MARK_LEADER_LINE_LENGTH_FOR_PERPENDICULAR

Category: Marking - general

Use this advanced option to control the length of the perpendicular leader lines of rebar group marks. The default value is 0.

This advanced option is role specific. When the type **SYSTEM(ROLE)** is in use, the default value is used. When the type **MODEL(ROLE)** or **DRAWING(ROLE)** is

in use, you can change the value, which is then the same for all users in the current model.

14.15 XS_MARK_LEADER_LINE_POSITION_TYPE_FOR_NO_FRAME

Category

Marking: General

Use to define the leader line position of a leader line pointing to a mark:

- without a mark frame (mark frame deleted from the **General** page of the mark properties dialog box)
- without a mark frame but with a mark element frame (mark frame deleted from the **General** page, and element frame selected on the **Content** page of the mark properties dialog box).

The default value is 0.

TIP You may want to keep the default value 0 for the advanced option XS_MARK_LEADER_LINE_EXTENSION_LENGTH, when using XS_MARK_LEADER_LINE_POSITION_TYPE_FOR_NO_FRAME.

This advanced option is role specific. When the type **SYSTEM(ROLE)** is in use, the default value is used. When the type **MODEL(ROLE)** or **DRAWING(ROLE)** is in use, you can change the value, which is then the same for all users in the current model.

Example

| Position | Appearance | Set the advanced option to |
|-----------------|---|----------------------------|
| Nearest corner. |  <p>HSS COLUMN AS PER PLAN AND SCHEDULE</p> | 0 |

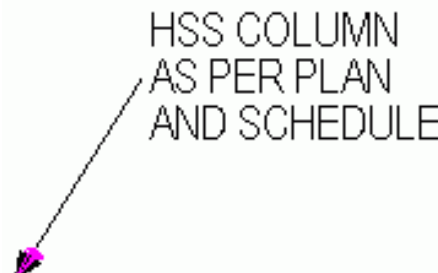
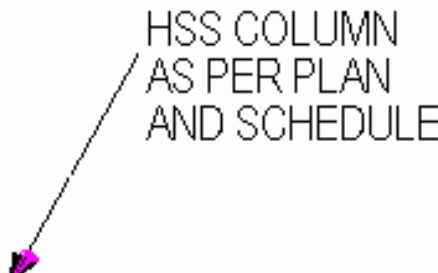
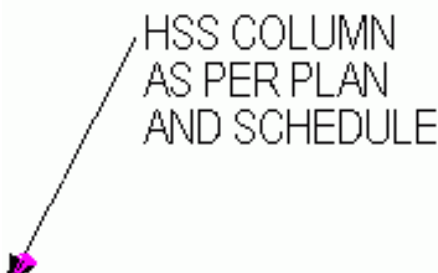
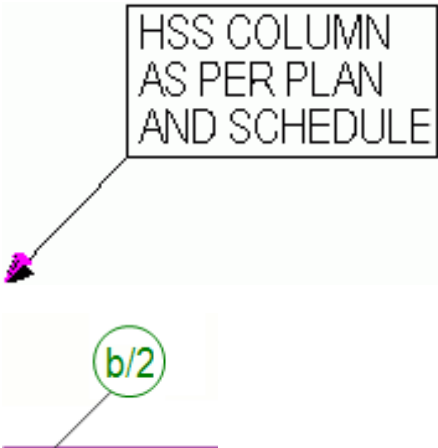
| Position | Appearance | Set the advanced option to |
|--|--|----------------------------|
| In the middle of the text area. |  | 1 |
| 1/3 from the top of the text area. |  | 2 |
| In the middle of the first row of text. |  | 3 |
| <p>The leader line connects to the frame around the mark element (not to the frame around the whole mark). The mark frame has been deleted in the mark properties.</p> <div data-bbox="311 1435 485 1496" style="border: 1px solid gray; padding: 2px; display: inline-block;">123 ▼</div> |  | 4 |

See also

[XS_MARK_LEADER_LINE_POSITION_TYPE_FOR_RECTANGULAR_FRAME](#)
(page 294)

[XS_MARK_LEADER_LINE_EXTENSION_LENGTH](#) (page 291)

14.16 XS_MARK_LEADER_LINE_POSITION_TYPE_FOR_RECTANGULAR_FRAME

Category

Marking: General

Use to define the leader line position for a leader line with a rectangular frame. The default value is 0.

This advanced option is model specific and the setting is saved in the options database.

Example

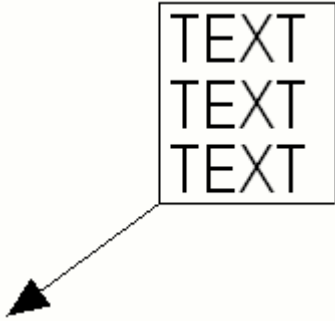
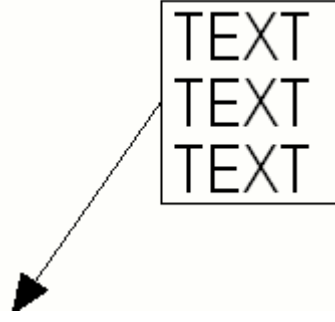
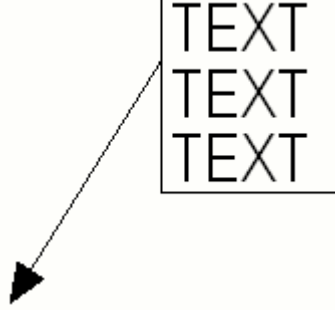
| Position | Appearance | Set the advanced option to |
|------------------------------------|---|----------------------------|
| Nearest corner. |  | 0 |
| In the middle of the text area. |  | 1 |
| 1/3 from the top of the text area. |  | 2 |

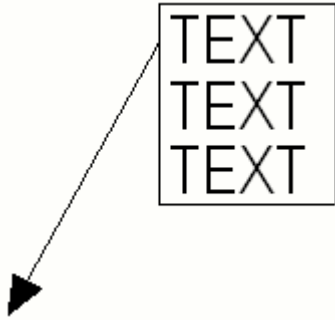
| Position | Appearance | Set the advanced option to |
|---|---|----------------------------|
| In the middle of the first row of text. |  | 3 |

See also

[XS_MARK_LEADER_LINE_POSITION_TYPE_FOR_NO_FRAME \(page 292\)](#)

14.17 XS_MARK_LINE_SPACE_FACTOR

Category: Marking - general

By default, Tekla Structures leaves a space of $0.3 \times \text{text height}$ between the lines in multi-line marks, for example, part, bolt, and connection marks. Use this advanced option to change the default value. This advanced option also affects the space between the lines in normal multi-line text objects.

This advanced option is model specific and the setting is saved in the options database.

In the example below, the value was changed from 0.3 to 1.

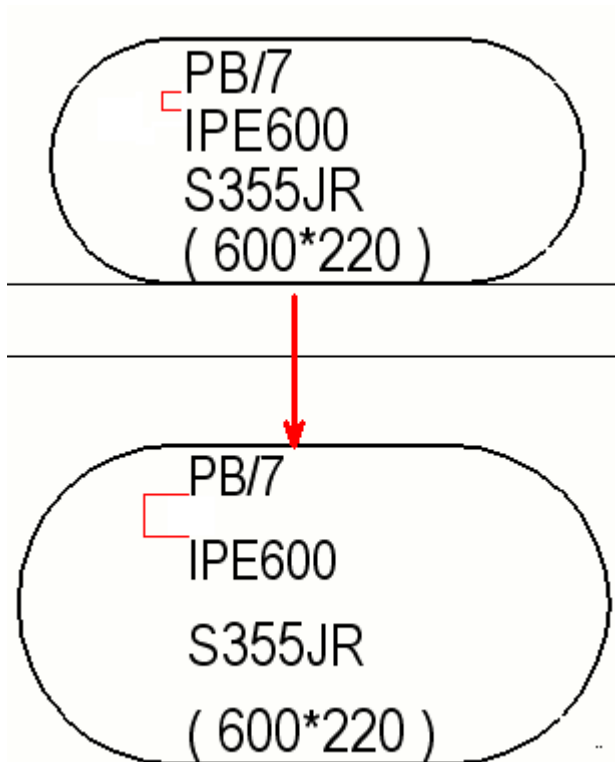

14.18 XS_MARK_PLACING_ANGLE_CLOSE_TO_45_DEGREES

Category: Marking - general

To place marks with leader lines in a 45-degree angle if allowed by the protection settings, ensure that the advanced option `XS_MARK_PLACING_ANGLE_CLOSE_TO_45_DEGREES` is set to `TRUE`. `TRUE` is the default value.

This advanced option is model specific and the setting is saved in the options database.

See also

[XS_MARK_INTELLIGENT_PLACING](#) (page 289)

14.19 XS_MARK_TEXT_FRAME_BOX_HEIGHT_FACTOR

Category

Marking: General

By default Tekla Structures leaves a space of $0.5 \times \text{text height}$ between the text and the frame around the text. Use this advanced option to change the default value.

This advanced option is model specific and the setting is saved in the options database.

In the example below, the value was changed from 0.5 to 2.



14.20 XS_MATERIAL_SYMBOL_REPRESENTATION_FILE

Category: Drawing properties

Enter the folder path and filename of the file containing the user-defined material symbols, for example `material_symbol_table.txt`.

This advanced option is model specific and the setting is saved in the options database.

14.21 XS_MAX_ANGLE_BETWEEN_SKEWED_END_PLATE_AND_BEAM_END

Category

Drawing Properties

Use to produce section views and dimensions of slightly skewed end plates. An end plate can be sloping or skewed to such a small degree that it is unnecessary to bevel cut the end of the main part. If the end plate is not dimensioned in the section view, you need to set a limit for the end plate angle.

Tekla Structures dimensions any end plate skewed less than this value in section views. Larger angle dimensions do not appear in the section view. Set

the angle between the skewed end plate and beam in degrees. The default angle is 0.

This advanced option is role specific. When the type **SYSTEM(ROLE)** is in use, the default value is used. When the type **MODEL(ROLE)** or **DRAWING(ROLE)** is in use, you can change the value, which is then the same for all users in the current model.

14.22 XS_MAX_ANGLE_TOLERANCE_BETWEEN_COMPLEX_MAIN_PARTS

Category

Dimensioning: Parts

Use to define the maximum angle range (0...1) within which Tekla Structures will dimension non-parallel parts as one. The default value is 0.01.

This advanced option is role specific. When the type **SYSTEM(ROLE)** is in use, the default value is used. When the type **MODEL(ROLE)** or **DRAWING(ROLE)** is in use, you can change the value, which is then the same for all users in the current model.

14.23 XS_MAX_AUTOMATIC_RADIUS_DIMENSION

Category

Dimensioning: Parts

Defines the maximum radius when you use automatic radius in single part drawings. The default value is 5000. Tekla Structures will display radii smaller than the value you enter in drawings.

This advanced option is model specific and the setting is saved in the options database.

14.24 XS_MAX_DECIMALS_IN_PROFILE_NAME

Category: Profiles

Use this advanced option to control the number of decimals in profile names, for example, in NC file headers. The default value is 1.

-
- NOTE** • This advanced option only affect plates created directly in the model. The advanced option [XS_PLATE_ROUNDING_DECIMALS \(page 331\)](#) affects plates created by components.
- This advanced option works on plates only if you set the advanced option [XS_USE_NEW_PLATE_DESIGNATION \(page 481\)](#) to `TRUE` in the **Plate work** category of the **Advanced options** dialog box.
-

14.25 XS_MAX_DEVIATION_FOR_CURVED_PART_EDGES

Category

Concrete Detailing

When you camber a part, Tekla Structures calculates all the part vertices to be on a circle arc, but all span edges between two vertices are approximations of the arc. Use this advanced option to limit the maximum distance by which the edge can deviate from the arc.

Define the value in millimeters. The default is 2.0. The minimum value is 0.1.

This advanced option is model specific and the setting is saved in the options database.

See also

[XS_WARP_MAX_ANGLE_BETWEEN_CS \(page 510\)](#)

14.26 XS_MAX_FRACTIONS_IN_MODEL_DIMENSION

Category

Imperial Units

Defines the measuring accuracy in models in the US environment Imperial role. For example, this accuracy affects the imperial measurements shown with the **Measure** tool. You can enter any number, but you should use numbers such as 8, 16, 32, 64, 128 and 256. The default value is 16.

This advanced option is role specific. When the type **SYSTEM(ROLE)** is in use, the default value is used. When the type **MODEL(ROLE)** or **DRAWING(ROLE)** is in use, you can change the value, which is then the same for all users in the current model.

Example

To use the accuracy of 1/32, set this advanced option to 32.

14.27 XS_MAXIMUM_NUMBER_OF_PLANES_TO_NAME

Category

Modeling Properties

Use to define how many planes Tekla Structures names when the planes are used, for example, in defining distance variables. The default value is 400.

When the maximum number of planes is reached, Tekla Structures stops naming the planes and uses the name **Undefined plane** for the rest of the planes.

This advanced option is model specific and the setting is saved in the options database.

14.28 XS_MAX_MERGE_DISTANCE_IN_HORIZONTAL

Category

Marking: Parts

Defines the maximum horizontal distance within which identical reinforcement get merged marks. This advanced option only affects merging of reinforcing bar marks pointing to individual reinforcing bars, not marks pointing to a group of reinforcing bars, or marks within a group of reinforcing bars. The default value is 600 mm.

This advanced option is model specific and the setting is saved in the options database.

See also

[XS_MAX_MERGE_DISTANCE_IN_VERTICAL \(page 300\)](#)

14.29 XS_MAX_MERGE_DISTANCE_IN_VERTICAL

Category

Marking: Parts

Defines the maximum vertical distance within which identical reinforcement get merged marks. This advanced option only affects merging of reinforcing bar marks pointing to individual reinforcing bars, not marks pointing to a group of reinforcing bars, or marks within a group of reinforcing bars. The default value is 600 mm.

This advanced option is model specific and the setting is saved in the options database.

See also

[XS_MAX_MERGE_DISTANCE_IN_HORIZONTAL \(page 300\)](#)

14.30 XS_MAX_SPACE_BETWEEN_COMPLEX_ASSEMBLY_PARALLEL_PARTS

Category

Dimensioning: Parts

Use to define the maximum distance allowed between parallel parts for Tekla Structures to dimension them as one. The default value is 1000.

This advanced option is role specific. When the type **SYSTEM(ROLE)** is in use, the default value is used. When the type **MODEL(ROLE)** or **DRAWING(ROLE)** is in use, you can change the value, which is then the same for all users in the current model.

14.31 XS_MDIBASICVIEWPARENT

Category

Model View

Set this advanced option to `TRUE` (default) to allow connection or default view windows to be moved within the Tekla Structures window.

Set this advanced option to `FALSE` to allow connection or default view windows to be moved anywhere on the Windows desktop.

This advanced option is user specific and the setting is saved in `options.bin` under the user folder, for example, in `C:\Users\<user>\AppData\Local\Trimble\Tekla Structures\<version>\UserSettings`. Restart Tekla Structures to activate the new value.

See also

[XS_MDIVIEWPARENT \(page 302\)](#)

14.32 XS_MDIVIEWPARENT

Category

Model View

Set this advanced option to `TRUE` to allow view windows to be moved only within the Tekla Structures window.

Set this advanced option to `FALSE` to allow view windows to be moved anywhere on the Windows desktop. This gives you more workspace on the screen, because view windows move to the front when you click on them and open dialog boxes remain behind the views. It also allows you to enlarge Tekla Structures windows to fill the entire desktop.

The default value is `TRUE`.

This advanced option is user specific and the setting is saved in `options.bin` under the user folder, for example, in `C:\Users\\AppData\Local\Trimble\Tekla Structures\\UserSettings`. Restart Tekla Structures to activate the new value.

NOTE This advanced option also affects drawing windows. Use the advanced options `XS_MDIZOOMPARENT` and `XS_MDIBASICVIEWPARENT` to control connection and default views and zoom views .

See also

[XS_MDIZOOMPARENT \(page 302\)](#)

[XS_MDIBASICVIEWPARENT \(page 301\)](#)

14.33 XS_MDIZOOMPARENT

Category: Model views

This option affects zoom windows, which can be created when editing drawings by using the **Create zoom window** command in the context menu or **Quick Launch**.

Set this advanced option to `TRUE` to allow zoom windows to be moved only within the Tekla Structures window.

Set this advanced option to `FALSE` (default) to allow zoom windows of views to be moved anywhere on the Windows desktop.

This advanced option is user specific and the setting is saved in `options.bin` under the user folder, for example, in `C:\Users\\AppData\Local\Trimble\Tekla Structures\\UserSettings`. Restart Tekla Structures to activate the new value.

14.34 XS_MESSAGES

This advanced option is deprecated, but still supported in Tekla Structures version 2022 and older Tekla Structures versions. Instead of this advanced option, we recommend that you use [XS_MESSAGES_PATH \(page 303\)](#), which allows you to define several message file locations.

This advanced option must be set in an initialization (.ini) file.

Use to define the location of the message files. All message files have the file name extension `.ail`.

This advanced option is system specific and is read from `teklastructures.ini`. Generally, there is no need to modify system-specific settings. Do not modify them if you are not an administrator.

14.35 XS_MESSAGES_PATH

This advanced option must be set in an initialization (.ini) file.

Use to define the locations of message files for user interface text. Message files include translated texts in the languages in which the Tekla Structures user interface is available.

This advanced option is system specific and is read from `teklastructures.ini`. It can also be set locally, see your environment `.ini` file (`env_<environment_name>.ini`). Generally, there is no need to modify system-specific settings. Do not modify them if you are not an administrator.

If you are an administrator, we recommend that you use the environment file for your `.ail` files.

14.36 XS_MESSAGES_PATH_INTERNAL

This advanced option must be set in an initialization (.ini) file.

WARNING Do not change the value of this advanced option.

This advanced option is only meant for administrators.

This advanced option defines the location of `.ail` files that are used internally by Tekla Structures. This folder is always read by default.

If you have previously defined the locations of folders for customized user interface text using the `XS_MESSAGES_PATH` advanced option and want to continue using your customizations, you can optionally disable the use of the internal messages folder. Add

```
XS_DISABLE_MESSAGES_PATH_INTERNAL=true
```

 to your environment `.ini` file (`env_<environment_name>.ini`).

NOTE Disabling the use of the internal messages folder might cause some translations for components to be missing or incorrect.

14.37 XS_MIN_DISTANCE_FOR_CONNECTING_SIDE_MARK

Category Marking - general

Use this advanced option to set the minimum distance of the connecting part from the main part so that when the distance is larger than the value you enter, Tekla Structures draws a connecting side mark to show that there is a part farther away from the main part that is connected to the part. When the distance is smaller than the value you enter, no mark is drawn. The default value is 300 mm.

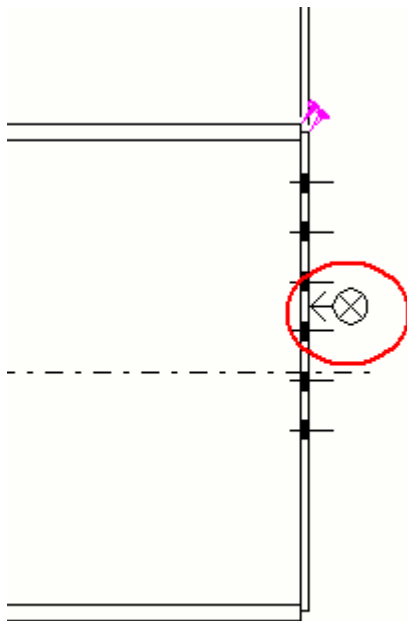

This advanced option is model specific and the setting is saved in the options database.

14.38 XS_MIN_MERGE_PART_COUNT

Category: Marking - parts

Use to define the minimum number of identical parts whose marks to merge. The default value is 2.

This advanced option is model specific and the setting is saved in the options database.

14.39 XS_MIN_NUMBER_OF_ASSEMBLY_MULTI_CHARACTERS

Category: Numbering

Use to set the minimum number of characters in assembly multinumbers.

This advanced option is model specific and the setting is saved in the options database.

Example

If you set this advanced option to 3, the multinumber format is 101AAA.

See also

[XS_USE_MULTI_NUMBERING_FOR](#) (page 480)

[XS_VALID_CHARS_FOR_ASSEMBLY_MULTI_NUMBERS](#) (page 501)

[XS_ASSEMBLY_MULTI_NUMBER_FORMAT_STRING](#) (page 55)

[XS_MIN_NUMBER_OF_PART_MULTI_CHARACTERS](#) (page 305)

14.40 XS_MIN_NUMBER_OF_PART_MULTI_CHARACTERS

Category: Numbering

Use to define the minimum number of characters in part multinumbers.

This advanced option is model specific and the setting is saved in the options database.

Example

If you set this advanced option to 3, the multinumber format is 101aaa.

See also

[XS_USE_MULTI_NUMBERING_FOR](#) (page 480)

[XS_VALID_CHARS_FOR_PART_MULTI_NUMBERS](#) (page 502)

[XS_PART_MULTI_NUMBER_FORMAT_STRING \(page 327\)](#)

[XS_MIN_NUMBER_OF_ASSEMBLY_MULTI_CHARACTERS \(page 305\)](#)

14.41 XS_MIN_WELD_LINE_LENGTH

Category: Welds

Defines the minimum length of the weld mark reference line. If symbols and other data exceed the minimum length of weld mark reference line, weld mark reference line extends to contain all symbols and data. Enter the value in millimeters.

This advanced option is model specific and the setting is saved in the options database.

14.42 XS_MIS_FILE_DIRECTORY

Category: CNC

Points to the folder where NC and MIS files are created. The default is the current model folder.

This advanced option is model specific and the setting is saved in the options database.

The following table shows where the NC files are created with different values entered in the **File location** box in the **NC File Settings** dialog box, and XS_MIS_FILE_DIRECTORY is set to C:\NC:

| Path in File location | NC files are created in |
|-----------------------|-------------------------|
| empty | C:\NC\ModelName |
| .\ | C:\NC\ModelName |
| .\MyFiles | C:\NC\ModelName\MyFiles |

14.43 XS_MIS_SEQUENCE

Category

Export

Use to enable sequences in EJE and KISS file type MIS exports.

Define which part property is used as the sequence information. The options are:

- CLASS
- PHASE_NUMBER (default)
- PHASE_NAME
- UDA:USER_PHASE

NOTE The maximum lengths of the sequence information fields are 10 and 4 characters in KISS and EJE file types, respectively. Do not use long names for phase names or user phases, if you are using this information as MIS Sequence.

This advanced option is user specific and the setting is saved in `options.bin` under the user folder, for example, in `C:\Users\<user>\AppData\Local\Trimble\Tekla Structures\<version>\UserSettings`. Restart Tekla Structures to activate the new value.

14.44 XS_MODEL_BACKUP_DIRECTORY



Category: File Locations

Enter the path to the folder where you want to store the backup copies of Tekla Structures model files. You can enter either an absolute path or a relative path. For example, you can enter a path to a mapped network drive. Model files are often large, so you should ensure that you enter a path to a location that has enough disk space.

Tekla Structures will create sub-folders for each Tekla Structures model under the folder path that you enter. Each one of these model folders will contain sub-folders for each time a backup copy of the model has been saved. These sub-folders are named by the times when backup copies have been created in the `YYYYMMDD-HHMMSS` format.

System (C:) > TeklaStructuresModels > backup > New model

Name

-  20200915-171500
-  20201007-152003
-  20201015-160015

The default folder for backup copies is `..\TeklaStructuresModels\backup\`. If you do not enter another path, the default folder is used.

Note that the backup folder cannot be located directly under the actual model folder, because it would cause an infinite loop. If you define the backup folder

to be in the model folder, Tekla Structures will ignore the path and use the default folder instead.

If Tekla Structures cannot find the folder path you entered, the status bar will tell you that creating a backup file has failed.

This advanced option is user specific and the setting is saved in `options.bin` under the user folder, for example, in `C:\Users\\AppData\Local\Trimble\Tekla Structures\\UserSettings`. Restart Tekla Structures to activate the new value.

14.45 XS_MODEL_IMPORT_LOCK_OBJECTS

Category: Import

Set this advanced option to `TRUE` to lock all the imported objects. When you do this, the user-defined attribute **Locked** is automatically set to **Yes** in the user-defined attributes dialog box of the imported objects. `TRUE` is the default value.

This advanced option is model specific and the setting is saved in the options database.

14.46 XS_MODEL_PREFIX_INFLUENCES_MULTI_NUMBERING_FOR

Category: Numbering

Use to define whether part and assembly number prefixes affect the numbering of parts and assemblies in multidrawings. The options are `NONE`, `ASSEMBLIES`, `PARTS` and `ASSEMBLIES_AND_PARTS`. The value field is empty by default.

This advanced option is model specific and the setting is saved in the options database.

See also

[XS_USE_MULTI_NUMBERING_FOR \(page 480\)](#)

[XS_USE_MODEL_PREFIX_IN_MULTI_NUMBERS_FOR \(page 479\)](#)

14.47 XS_MODEL_TEMPLATE_DIRECTORY

Category: File Locations

Enter the path to the folder where Tekla Structures saves model templates. Enter only one folder path. Only the templates saved in this folder are listed in the **Model template** list in the **New** dialog box.

For example, you can set this advanced option to point to the same location as [XS_FIRM \(page 238\)](#).

By default, the model template folder is saved in your environment folder, under `..ProgramData\Trimble\Tekla Structures\<version>\environments\<your environment>\`. The exact folder location may vary depending on your environment and role.

This advanced option is user specific and the setting is saved in `options.bin` under the user folder, for example, in `C:\Users\<user>\AppData\Local\Trimble\Tekla Structures\<version>\UserSettings`. Restart Tekla Structures to activate the new value.

14.48 XS_MULTIDRAWING_KEEP_OBSOLETE_DRAWINGS

Category

Drawing Properties

Use this advanced option for controlling the views and multinumbers of deleted assemblies in multidrawings. Set this advanced option to `TRUE` to preserve the views of deleted parts and assemblies and to reserve the multinumbers of the deleted parts and assemblies. Set it to `FALSE` to reuse the multinumbers of the deleted assemblies and to delete the views. The default value is `FALSE`.

This advanced option is model specific and the setting is saved in the options database.

14.49 XS_MULTIDRAWING_REMOVE_VIEW_LABEL_GAP

Category

Drawing Properties

Set this advanced option to `TRUE` to remove unnecessary space between the drawing view label and the drawing view in multidrawings. If you do not want to do this, use `FALSE` (default).

This advanced option is model specific and the setting is saved in the options database.

14.50 XS_MULTI_DRAWING_VIEW_PLACING_TRIAL_NUMBER

Category

This advanced option must be set in an initialization (.ini) file.

Use to define the number of attempts to place the drawing views into a multidrawing. Enter an integer between 1 and 500. The advanced option is set to 500 by default.

14.51 XS_MULTI_DRAWING_VIEW_TITLE

Category: Drawing properties

Use to define a title for a multidrawing view in a multidrawing. You can define plain text or use some switches (`BASE_NAME` and `NAME`) as the value.

By default the title is defined as follows:

```
Drawing %DRAWING_BASE_NAME%
```

For details about creating multidrawings, see [Create multidrawings](#).

This advanced option is model specific and the setting is saved in the options database.

14.52 XS_MULTI_NUMBERING_INCLUDE_ASSEMBLY_PARTS

Category: Numbering

Set this advanced option to `TRUE` to include single parts in multinumbering. If this advanced option is set to `FALSE`, single parts get multinnumbers only if they are included in an assembly drawing.

The default value is `FALSE`.

This advanced option is model specific and the setting is saved in the options database.

See also

[XS_USE_MULTI_NUMBERING_FOR](#) (page 480)

14.53 XS_MULTIPLIER_SEPARATOR_FOR_MERGED_PART_MARK

Category: Marking - parts

Use to define the separator in merged part marks. The default value is x.

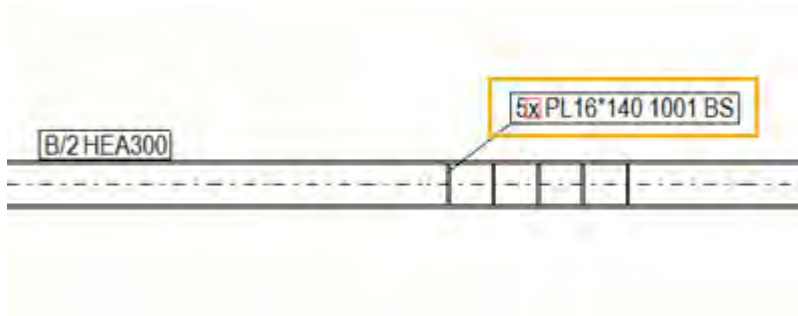

This advanced option is model specific and the setting is saved in the options database.

14.54 XS_MULTUSER_SAVE_REOPEN_DISABLE_COMPACTION

This advanced option must be set in an initialization (.ini) file. We recommend that you use the `options.ini` file in the model folder.

Use this advanced option only if you frequently get the error `The command could not be completed, restart Tekla Structures and try again.` during saving a multi-user model. Set the value to `TRUE` to prevent the error, and reopen the model. The default value is `FALSE`.

15 Advanced options - N

15.1 XS_NEIGHBOUR_PART_SKEW_LIMIT

Category

Drawing Properties

Tekla Structures considers neighboring parts as skewed if the product of the vector multiplication (part axis) (any of the coordinate axis) is less than 1-`XS_NEIGHBOUR_PART_SKEW_LIMIT`. Enter the limit as a floating value, for example 0.1 (default).

This advanced option is model specific and the setting is saved in the options database.

15.2 XS_NO_AUTO_DISPLAY_VIEWS

Category

Model View

Set this advance option to `TRUE` to prevent Tekla Structures from displaying views automatically when you start the program. Set it to `FALSE` (default) to display the views automatically. Views that are not visible remain not visible. Only visible views are shown.

This advanced option is user specific and the setting is saved in `options.bin` under the user folder, for example, in `C:\Users\<user>\AppData\Local\Trimble\Tekla Structures\<version>\UserSettings`. Restart Tekla Structures to activate the new value.

15.3 XS_NO_BOLT_ANGLE_DIMENSIONS

Category

Dimensioning: Bolts

To create angle dimensions for bolts, set this advanced option to `FALSE`. To not create angle dimensions for bolts, select `TRUE` (default).

This advanced option is model specific and the setting is saved in the options database.

15.4 XS_NO_CHAMFERS_IN_EXACT_MODE

Category

Model view

Set this advanced option to `TRUE` to prevent Tekla Structures from creating chamfers in exact mode. To create the chamfers in exact mode, set it to `FALSE`.

By default chamfers are created. This advanced option only affects wire frame views.

This advanced option is user specific and the setting is saved in `options.bin` under the user folder, for example, in `C:\Users\\AppData\Local\Trimble\Tekla Structures\\UserSettings`. Restart Tekla Structures to activate the new value.

15.5 XS_NO_END_VIEWS_TO_INCLUDED_SINGLE_DRAWINGS

Category

Single Part View in Assembly Drawing

Set this advanced option to `TRUE` (default) to prevent Tekla Structures from creating end views when you create an assembly drawing and choose to include single-part drawings. If you do not want to do this, set it to `FALSE`.

If you do not enter a value, Tekla Structures creates end views based on the properties of the single-part drawings.

This advanced option is model specific and the setting is saved in the options database.

15.6 XS_NO_RELATIVE_SHAPE_DIMENSIONS

Category

Dimensioning: Parts

Set this advanced option to `TRUE` to force shape dimensions to be the same as the dimension type you select.

By default, automatic shape dimensions are always relative regardless of the selected dimension type.

This advanced option does not affect single-part drawings. To affect single part drawings, use the advanced option

`XS_SINGLE_NO_RELATIVE_SHAPE_DIMENSIONS`.

This advanced option is model specific and the setting is saved in the options database.

See also

[XS_SINGLE_NO_RELATIVE_SHAPE_DIMENSIONS \(page 427\)](#)

15.7 XS_NO_UNFOLDING_LINES_TO_DRAWINGS

Category

Dimensioning: Unfolding

Use to define whether unfolding lines are shown in drawings. When you set the advanced option to `TRUE`, the unfolding lines are not shown. The default is `FALSE`.

This advanced option is model specific and the setting is saved in the options database.

15.8 XS_NO_SINGLE_PART_DRAWINGS_FOR

Category

Single Part View in Assembly Drawing

Set as follows to prevent Tekla Structures producing single part drawings for assemblies containing one part:

`XS_NO_SINGLE_PART_DRAWINGS_FOR=LOOSE_PARTS`

This advanced option is model specific and the setting is saved in the options database.

15.9 XS_NORTH_MARK_SCALE

Category

Marking: Parts

Use this advanced option to define the scale of the north mark symbol. By default, North marks have a scale of 1:1. You can also create a larger symbol for north marks in the Symbol editor.

This advanced option is model specific and the setting is saved in the options database.

15.10 XS_NORTH_MARK_SYMBOL

Category: Marking: Parts

By default the north mark symbol is number 32 in the symbol file `xsteel.sym`. Use this advanced option to change the symbol.



This advanced option is model specific and the setting is saved in the options database.

See also

Show orientation marks (north marks)

15.11 XS_NSFS_POSTFIX_FOR_MERGED_PART_MARK

Category: Marking - parts

Use to define the postfix in merged part marks. This postfix is visible for identical parts on both side of a main part. The default value is BS (both sides). Other possible values are NS (near side) and FS (far side).

This advanced option is model specific and the setting is saved in the options database.

In merging part marks, you may also find the following advanced options useful:

[XS_MULTIPLIER_SEPARATOR_FOR_MERGED_PART_MARK \(page 311\)](#)

[XS_NS_POSTIX_FOR_MERGED_PART_MARK \(page 317\)](#)

[XS_FS_POSTIX_FOR_MERGED_PART_MARK \(page 241\)](#)

[XS_PART_MERGE_MAX_DISTANCE \(page 327\)](#)

[XS_MIN_MERGE_PART_COUNT \(page 304\)](#)

15.12 XS_NSFS_TEXT_POSITION_IN_PART_MARK

Category: Marking - parts

Use to define which element the NS (near side), FS (far side) and BS (both sides) text follows in merged part marks.

The default is 23, which means that the text is located after the part position. If the element type that is defined by the advanced option cannot be found in the mark at all, the text will be located at end of the mark. To force the text to always appear at the end of the mark, use -1.

This advanced option is model specific and the setting is saved in the options database.

The following list contains the mark element types and the corresponding integer values:

TEXT = 1

LINE FEED = 2

SYMBOL = 3

FRAME START = 4

FRAME END = 5

MATERIAL = 10

USER DEFINED ATTRIBUTE = 16

ASSEMBLY_POSITION = 22

PART_POSITION = 23

PROFILE = 24

NAME = 25

LENGTH = 26

CAMBER = 27

SIZE = 28

FITTINGS (NS/FS) = 29
CLASS = 38
BACK_SPACE = 46
GAGE OF OUTSTANDING LEG = 48
CENTER TO CENTER DISTANCE = 49
FACE_DIRECTION = 57
END OF Mark = -1

Example

`XS_NSFS_TEXT_POSITION_IN_PART_MARK=22`

The value 22 means after assembly position.

NOTE The NS, FS, or BS text itself comes from two separate places depending on if the marks are merged or not. For ordinary marks, the text comes from a file called `by_number.ail` (NS: `by_number_msg_no_675`, FS: `by_number_msg_no_676`). For merged marks, the text comes from the following advanced options:

- BS: `XS_GET_NSFS_POSTFIX_FOR_MERGED_PART_MARK`
 - NS: `XS_GET_NS_POSTFIX_FOR_MERGED_PART_MARK`
 - FS: `XS_GET_FS_POSTFIX_FOR_MERGED_PART_MARK`
-

15.13 XS_NS_POSTFIX_FOR_MERGED_PART_MARK

Category: Marking - parts

Use to define the near side (NS) postfix in merged part marks. This postfix is visible for identical parts on near side. The default value is NS.

This advanced option is model specific and the setting is saved in the options database.

In merging part marks, you may also find the following advanced options useful:

[XS_MULTIPLIER_SEPARATOR_FOR_MERGED_PART_MARK](#) (page 311)

[XS_NSFS_POSTIX_FOR_MERGED_PART_MARK](#) (page 315)

[XS_FS_POSTIX_FOR_MERGED_PART_MARK](#) (page 241)

[XS_PART_MERGE_MAX_DISTANCE](#) (page 327)

[XS_MIN_MERGE_PART_COUNT](#) (page 304)

15.14 XS_NUMBERING_RESULTS_DIALOG_DISPLAY_TIME

Category: Numbering

Use to set the time frame within which Tekla Structures makes the second save when numbering when you have selected the **Synchronize with master model (save-numbering-save)** option in the **Numbering Setup** dialog box.

Enter the desired time in seconds. The advanced option is set to 1500 by default.

This advanced option is model specific and the setting is saved in the options database.

16 Advanced options - O

16.1 XS_OBJECT_SELECTION_CONFIRMATION

Category

Modeling Properties

Enter the time in milliseconds after which Tekla Structures prompts you to cancel object selection. You can cancel the object selection process if the selection takes longer than the defined time.

The default value is 5000.

This advanced option is user specific and the setting is saved in `options.bin` under the user folder, for example, in `C:\Users\\AppData\Local\Trimble\Tekla Structures\\UserSettings`. Restart Tekla Structures to activate the new value.

16.2 XS_OBJECTLOCK_DEFAULT

Category

Modeling Properties

Set the default lock status for new assemblies or cast units when they are created. Additionally, when you start to share the model in Tekla Model Sharing, the default lock status is set for all assemblies and cast units that do not yet have any lock status. The locked status is shown in the **Locked** value in the **Object locks** dialog box. The value options are `ORGANIZATION` or `NO`.

This advanced option is system specific.

16.3 XS_OMIT_MARKS_OF_HIDDEN_PARTS_IN_GA_DRAWINGS

Category

Marking: Parts

Set this advanced option to `TRUE` to hide part marks of parts hidden by other parts from views in general arrangement drawings. The default value is `FALSE`.

If you have stiffeners on either side of a beam, one will be hidden by the beam in front of it. Set this advanced option to `TRUE` to prevent Tekla Structures from displaying the part mark of the hidden part.

This advanced option is model specific and the setting is saved in the options database.

16.4 XS_OMIT_MARKS_OF_PARTS_OUT_OF_VIEW_PLANE_LIMIT_ANGLE

Category: Marking - general

Use to hide the part marks for parts outside the current view plane by defining the limit for inclusion as an angle. The default value is `20.0`.

You also need to set the **Parts out of view plane** option in the view level **Part mark properties** dialog box to **Not visible** to hide parts from the views that are outside the angle you specify here.

This advanced option is model specific and the setting is saved in the options database.

16.5 XS_OMITTED_BOLT_ASSEMBLY_TYPE

Category: Marking - bolts

Use this advanced option to filter out the given type of bolt marks when the **Ignore size** setting is set to a value in drawing bolt mark properties. The options are:

- `SITE` (default)
- `SHOP`
- `SITE_AND_SHOP`.

The default value `SITE` filters out only site bolt marks for bolts that meet the **Ignore size** value, whereas workshop bolt marks of all sizes are shown in drawings.

This advanced option is model specific and the setting is saved in the options database.

See also

[XS_OMITTED_BOLT_TYPE \(page 321\)](#)

16.6 XS_OMITTED_BOLT_TYPE

Category: Marking: Bolts

Use this advanced option to define which bolt standards to omit from drawings when a size has been defined for the **Ignore size** setting in drawing bolt mark properties. Enter the name of the bolt standard, for example, `7990`. You can also use wildcards, such as `*` or `?`. By default, no value is given, which means that no bolt standards are omitted.

Example: First define a value to **Ignore size**. To filter away all the marks of bolts of that size, and the marks of bolts of the bolt standards `A325N`, `A325X` and `A325SC`, set this advanced option to `A325*`.

This advanced option is model specific and the setting is saved in the options database.

See also

[XS_OMITTED_BOLT_ASSEMBLY_TYPE \(page 320\)](#)

[XS_OMITTED_DIAMETER_TYPE \(page 321\)](#)

[XS_GA_OMITTED_DIAMETER_TYPE \(page 244\)](#)

16.7 XS_OMITTED_DIAMETER_TYPE

Category

Marking: Bolts

Use to define the bolt diameter type of the marks to omit in drawings. The options are `HOLE` or `BOLT`.

This advanced option is used together with the drawing bolt mark property setting **Ignore size**. For example, to filter out all bolt marks of bolts that have a

hole diameter 22, enter 22 as the value for **Ignore size**, and set this advanced option to `HOLE`.

This advanced option is model specific and the setting is saved in the options database.

See also

[XS_OMITTED_BOLT_TYPE](#) (page 321)

16.8 XS_OMITTED_PART_NAME_IN_AUTOCONNECTION

Category

Components

Use to filter out specific part types when you use `AutoConnection`. `AutoConnection` cannot handle brace connections when large quantities of parts are selected.

This advanced option is model specific and the setting is saved in the options database.

Example

If you want to use this advanced option to filter out brace parts, set it to `brace`. Tekla Structures does not select any parts with names containing the string "brace".

TIP You can also do this by setting the **Selection Filter** to select all parts except for those named "brace*".

16.9 XS_OMITTED_WELD_TYPE

Category: Welds

Use to define which weld types to omit in drawings. Enter the number of the weld type you want to omit. The default value is 10 (fillet weld).

In addition to this advanced option there are two other settings that Tekla Structures uses to determine the welds that are shown in the drawing: `XS_WELD_FILTER_TYPE` tells if Tekla Structures should filter welds that are exactly (`EXACT`) the size or of the same size or smaller (`MIN`) than the value given in the **Weld size limit** box in the object or mark properties on the

drawing view level. Tekla Structures always shows welds that have reference text.

This advanced option is model specific and the setting is saved in the options database.

Example

If you set `XS_OMITTED_WELD_TYPE` to 10, `XS_WELD_FILTER_TYPE` to EXACT, and **Weld size limit** to 5, Tekla Structures shows all other welds except those that are 5 mm, and those of type fillet weld (10). In this case, if you do not set `XS_WELD_FILTER_TYPE`, Tekla Structures shows all welds that are bigger than 5 mm except fillet welds.

See also

[XS_WELD_FILTER_TYPE \(page 510\)](#)

16.10 XS_OPEN_DRAWINGS_MAXIMIZED

Category

Drawing View

Set to TRUE to maximize drawings when you open them. The default is FALSE.

This advanced option is user specific and the setting is saved in `options.bin` under the user folder, for example, in `C:\Users\<user>\AppData\Local\Trimble\Tekla Structures\<version>\UserSettings`. Restart Tekla Structures to activate the new value.

16.11 XS_ORIENTATION_MARK_DIRECTION

Category

Marking: parts

Use to define the direction of orientation marks. The options are NORTH-EAST, NORTH-WEST, SOUTH-EAST and SOUTH-WEST. NORTH-EAST is the default value.

This advanced option is model specific and the setting is saved in the options database.

See also

Show orientation marks (north marks)

[XS_NORTH_MARK_SYMBOL \(page 315\)](#)

16.12 XS_ORIENTATION_MARK_MOVE_DIST_FOR_BEAMS

Category: Marking - parts

Use to indicate the position of orientation marks for beams. Enter a value indicating the distance from the end of the part to the orientation mark. The default value is 300.0 mm. You can enter any value in the range 1.0 to 3000.0.

This advanced option is model specific and the setting is saved in the options database.

16.13 XS_ORIENTATION_MARK_MOVE_DIST_FOR_BEAMS_IN_GA

Category

Marking: Parts

Indicates the position of beam orientation marks in GA drawings. Enter a value indicating the distance from the end of the part to the orientation mark. The default value is 300.0 mm.

This advanced option is model specific and the setting is saved in the options database.

See also

[XS_ORIENTATION_MARK_MOVE_DIST_FOR_BEAMS \(page 324\)](#)

16.14 XS_ORIENTATION_MARK_MOVE_DIST_FOR_COLUMNS

Category: Marking - parts

Use to define the placing of orientation marks for columns. The value assigned to this advanced option is the distance from the end of the part to the orientation mark. The default value for columns is 300.0 mm. Possible values range from 1.0 to 3000.0.

This advanced option is role specific. When the type **SYSTEM(ROLE)** is in use, the default value is used. When the type **MODEL(ROLE)** or **DRAWING(ROLE)** is in use, you can change the value, which is then the same for all users in the current model.

16.15 XS_ORIENTATION_MARK_MOVE_DIST_FOR_COLUMNS_IN_GA

Category

Marking: Parts

Defines the position of column orientation marks in GA drawings. The value assigned to this advanced option is the distance from the end of the part to the orientation mark. The default value is 300.0 mm.

This advanced option is role specific. When the type **SYSTEM(ROLE)** is in use, the default value is used. When the type **MODEL(ROLE)** or **DRAWING(ROLE)** is in use, you can change the value, which is then the same for all users in the current model.

See also

[XS_ORIENTATION_MARK_MOVE_DIST_FOR_COLUMNS \(page 324\)](#)

17 Advanced options - P

17.1 XS_PARAMETRIC_PROFILE_SEPARATOR

Category

Profiles

Use this advanced option to define an additional character to separate dimensions in the name of parametric profiles. Tekla Structures always recognizes the standard separator characters X, *, -, and /. The default value is an asterisk (*).

For example, when you inquire a part with a sketched profile, the character specified by this advanced option is used as the separator.

Example

```
XS_PARAMETRIC_PROFILE_SEPARATOR=E
```

Acceptable profile names with this setting are:

1. PL500*800
2. PL500X800
3. PL500E800

Any combination of these is also accepted:

`ProfileName500*500-500*500E500` (the profile `ProfileName` should be defined).

Limitations

- Only one character is accepted as a value for this advanced option.
- You cannot use slash (/) in the US imperial environment.

See also

[XS_USER_DEFINED_PARAMETRIC_PROFILE_SEPARATORS \(page 498\)](#)

17.2 XS_PART_DIMENSION_PLANES_TABLE

Category: Dimensioning - parts

Use to indicate the path to the user-defined part dimension planes table. This table defines the planes in which dimensions are created. For example, you might want Tekla Structures to dimension round bars to the middle of the profile rather than the reference line.

You can also use a file name as a value. If the value is a file name, Tekla Structures searches for the file in the model, project, firm and profile folders (in this order).

This is a system-specific advanced option.

Example

```
XS_PART_DIMENSION_PLANES_TABLE=%XS_PROFDB%  
\dim_planes_table.txt
```

17.3 XS_PART_MERGE_MAX_DISTANCE

Category: Marking - parts

Use to define the maximum distance within which identical parts get merged marks. Units are in millimeters. The default value is 1200.

This advanced option is role specific. When the type **SYSTEM(ROLE)** is in use, the default value is used. When the type **MODEL(ROLE)** or **DRAWING(ROLE)** is in use, you can change the value, which is then the same for all users in the current model.

17.4 XS_PART_MULTI_NUMBER_FORMAT_STRING

Category: Numbering

Use to define multinumbers for single parts. Use the following options to define the contents of part marks. Use as many switches as you need, and enclose each one in percent symbols (%).

The available options are:

| Option | Description |
|-----------------------------|--------------------|
| %PART_MULTI_DRAWING_NUMBER% | Multidrawing name. |

| Option | Description |
|---|--|
| <code>%PART_MULTI_DRAWING_POS%</code> | Position of the single-part drawing inside the multidrawing. |
| <code>%PART_PREFIX%</code> | Part prefix in the model. |
| <code>%PART_POS%</code> | Part position number in the model. |
| Template fields | Enter <code>TPL:</code> followed by the name of any relevant template field. Enclose each name in percent symbols (%). For example, <code>%TPL:PROJECT.NUMBER%</code> |
| User-defined attributes that are defined in the <code>objects.inp</code> file | Enter <code>UDA:</code> followed by the name of any relevant user-defined attribute, exactly as it appears in the <code>objects.inp</code> file. For example, <code>%UDA:MY_INFO_1%</code> |

This advanced option is model specific and the setting is saved in the options database.

Example

To put the part multinumbers in the format part prefix + position on multidrawing + multidrawing name, set the advanced option as follows:

```
%PART_PREFIX%%PART_MULTI_DRAWING_POS%
%PART_MULTI_DRAWING_NUMBER%
```

See also

[XS_USE_MULTI_NUMBERING_FOR](#) (page 480)

[XS_ASSEMBLY_MULTI_NUMBER_FORMAT_STRING](#) (page 55)

[XS_CAST_UNIT_MULTI_NUMBER_FORMAT_STRING](#) (page 82)

17.5 XS_PART_POSITION_NUMBER_FORMAT_STRING

Category: Numbering

Use to have Tekla Structures use only letters in part numbers.

NOTE The advanced options [XS_ASSEMBLY_POSITION_NUMBER_FORMAT_STRING](#) (page 58) and `XS_PART_POSITION_NUMBER_FORMAT_STRING` override the advanced option [XS_SWITCH_POS_NUMBERS_FOR](#) (page 450). `XS_SWITCH_POS_NUMBERS_FOR` has no impact on assembly and/or part position numbers if you use `XS_ASSEMBLY_POSITION_NUMBER_FORMAT_STRING` and/or `XS_PART_POSITION_NUMBER_FORMAT_STRING`.

Enter any combination of the following options:

| Option | Description |
|-------------------------|--|
| %PART_PREFIX% | Part prefix, defined in the part properties in the property pane. |
| %PART_POS% | Part position number, defined by the start number (from part properties in the property pane) and the final position in that numbering series. |
| %PART_POS_WITH_LETTERS% | Same as above, but with letters. Uses letters A – Z by default, but you can also define valid letters with the advanced option XS_VALID_CHARS_FOR_PART_POSITION_NUMBERS. |

The position number/ letter switch can also include a suffix defining the minimum number of digits (or letters), for example: %PART_POS.3%. This example results in a first part number of 001, second 002 etc.

This advanced option is model specific and the setting is saved in the options database.

See also

[XS_VALID_CHARS_FOR_PART_POSITION_NUMBERS \(page 502\)](#)

17.6 XS_PART_POSITION_TO_EDGE_NEAREST_TO_NEIGHBOUR

Category: Dimensioning - parts

Set this advanced option to `TRUE` to dimension the position of parts to the edge that is nearest to the neighbor part. The default is `FALSE`.

In the image below, the neighbor parts in the model are blue, and the plate creation points are shown.

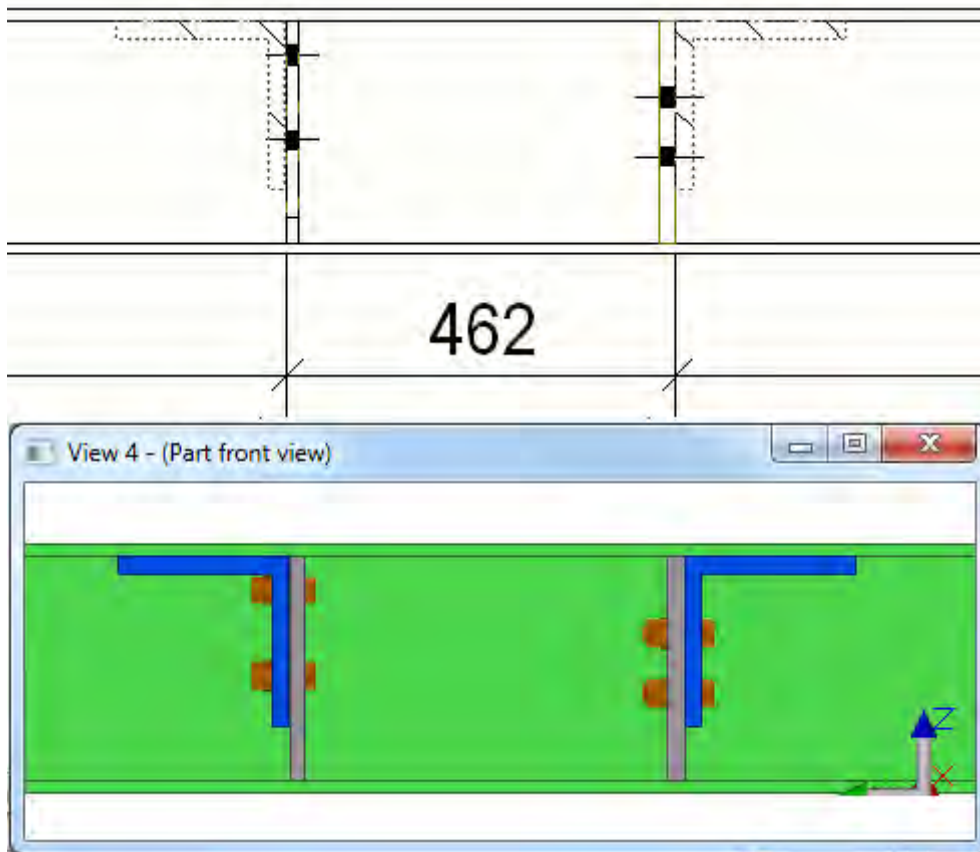

This advanced option is role specific. When the type **SYSTEM(ROLE)** is in use, the default value is used. When the type **MODEL(ROLE)** or **DRAWING(ROLE)** is in use, you can change the value, which is then the same for all users in the current model.

17.7 XS_PART_POSITION_TO_LEADING_EDGE

Category:Dimensioning - parts

Set this advanced option to `TRUE` (default) to dimension the position of beams to the leading edge. If you do not want to do this, set it to `FALSE`. For this advanced option to take effect, disable the advanced option `XS_USE_PLATE_SIDE_POSITIONING`.

For column assemblies, you must also set the advanced option `XS_PART_POSITION_TO_LEADING_EDGE_IN_COLUMNS_ALSO` to `TRUE`.

This advanced option is model specific and the setting is saved in the options database.

See also

[XS_PART_POSITION_TO_LEADING_EDGE_IN_COLUMNS_ALSO](#) (page 331)

[XS_USE_PLATE_SIDE_POSITIONING](#) (page 489)

17.8 XS_PART_POSITION_TO_LEADING_EDGE_IN_COLUMNS_ALSO

Category: Dimensioning - parts

To dimension part position to the leading edge for column assemblies, set this advanced option to `TRUE`. If you do not want to do this, set it to `FALSE`. The default value is `TRUE`.

You must also set the advanced option [XS_PART_POSITION_TO_LEADING_EDGE](#) (page 330) to `TRUE`.

This advanced option is model specific and the setting is saved in the options database.

17.9 XS_PIXEL_TOLERANCE

Category

Model View

Use to define the snap zone of objects. Each object has a snap zone, which defines how close you need to pick to hit a position. When you pick within the snap zone of an object, Tekla Structures automatically snaps to the closest pickable point on that object. Enter the value in pixels. The default value is 10.

This advanced option is user specific and the setting is saved in `options.bin` under the user folder, for example, in `C:\Users\<user>\AppData\Local\Trimble\Tekla Structures\<version>\UserSettings`. Restart Tekla Structures to activate the new value.

17.10 XS_PLATE_ROUNDING_DECIMALS

Category

Plate Work

Use to define the maximum number of decimals in plate profile name created by **components**. The default is 1.

Note that unnecessary zeroes are always left off, for example 10.501:

- with 2 decimals is 10.5
- with 3 decimals is 10.501

This advanced option is model specific and the setting is saved in the options database.

The advanced option `XS_MAX_DECIMALS_IN_PROFILE_NAME` controls decimals of plates that are modeled directly in the model.

See also

[XS_MAX_DECIMALS_IN_PROFILE_NAME \(page 298\)](#)

17.11 XS_PLOT_ORIGIN_MOVE_X

Category

This advanced option must be set in an initialization (.ini) file.

Offsets the print origin in the x direction. Use if a drawing does not fit to the paper or is printed to a wrong location. Enter the value in millimeters as an integer. This advanced option affects all printers. By default, this advanced option is not set to any value.

NOTE If you set these advanced options in your initialization files, you will override the **Printer Catalog** dialog box.

See also

[XS_PLOT_ORIGIN_MOVE_Y \(page 332\)](#)

17.12 XS_PLOT_ORIGIN_MOVE_Y

Category

This advanced option must be set in an initialization (.ini) file.

Offsets the print origin in the y direction. Use if a drawing does not fit to the paper or is printed to a wrong location. Enter the value in millimeters as an integer. This advanced option affects all printers. By default, this advanced option is not set to any value.

NOTE If you set these advanced options in your initialization files, you will override the **Printer Catalog** dialog box.

See also

[XS_PLOT_ORIGIN_MOVE_X](#) (page 332)

17.13 XS_PLOT_VIEW_FRAMES

Category

Printing

To show drawing view frames in printed and exported drawings, set `XS_PLOT_VIEW_FRAMES` to `TRUE`. `FALSE` is the default value.

This advanced option is model specific and the setting is saved in the options database.

17.14 PML_ASSEMBLY_MARKS_IN_USE

Category

Export

Set this advanced option to `TRUE` to have Tekla Structures use assembly marks in PML exports. By default this advanced option is set to `FALSE`, which means that Tekla Structures uses part marks.

This advanced option is model specific and the setting is saved in the options database.

17.15 PML_CARDINAL_POINT_NOT_IN_USE

Category

Export

Set this advanced option to `TRUE` to prevent Tekla Structures from using cardinal points in PML exports. This means that all parts will be defined by their center lines, and their position may differ from that in the Tekla Structures model. By default this advanced option is set to `FALSE`, which means that cardinal points are used in PML export. The default value is `FALSE`.

17.16 XS_PML_EXPORT_INCLUDE_GLOBAL_ID

Category

Export

Set this advanced option to `TRUE` to revert to the FrameWorksPlus ID number in PML exports. If you do not want to export the ID number, set it to `FALSE`. The default value is `FALSE`.

This advanced option is model specific and the setting is saved in the options database.

See also

[XS_SDNF_IMPORT_STORE_MEMBER_NUMBER \(page 394\)](#)

Export to CAD

17.17 XS_PML_EXPORT_USE_ADDITIONAL_CUT_DIST

Category

Export

Some earlier versions of Tekla Structures added 1 mm in length to fitted part ends in PML exports. Set this advanced option to `TRUE` to force recent versions to add the length. The default value is `FALSE`.

This advanced option is model specific and the setting is saved in the options database.

17.18 XS_POINT_CLOUD_CACHE_FOLDER

Category: File locations

Use this advanced option to define the folder where point cloud data is stored. By default, the folder is `%LocalAppData%\Trimble\Tekla Structures\PointClouds`, for example, `C:\Users\\AppData\Local\Trimble\Tekla Structures\PointClouds`.

This advanced option is user specific and the setting is saved in `options.bin` under the user folder, for example, in `C:\Users\\AppData\Local\Trimble\Tekla Structures\\UserSettings`. Restart Tekla Structures to activate the new value.

17.19 XS_POINT_CLOUDS_WEB_CACHE

Category: File locations

Use this advanced option to define the point cloud web streaming cache. By default, the folder is %LocalAppData%\Trimble\Trimble Connect\Import, for example, C:\Users\\AppData\Local\Trimble\Trimble Connect\Import.

17.20 XS_POLYBEAM_CHORD_TOLERANCE

Category: Speed and accuracy

Use this advanced option to define the chord tolerance for curved polybeam segments. Enter the value in millimeters. The default is 1.0.

Re-open the model to activate the new value.

NOTE Do not change the chord tolerance settings during a project. Changing them automatically recreates the curved polybeams when you re-open the model, resulting in slightly different solid objects, which may affect numbering, or the concrete covers of rebar sets, for example.

The advanced option XS_POLYBEAM_MAX_ANGLE_BETWEEN_CS works as limiting factor to XS_POLYBEAM_CHORD_TOLERANCE.

This advanced option is model specific and the setting is saved in the options database.

See also

[XS_POLYBEAM_MAX_ANGLE_BETWEEN_CS \(page 335\)](#)

[XS_CHORD_TOLERANCE_FOR_TUBE_SEGMENTS \(page 93\)](#)

17.21 XS_POLYBEAM_MAX_ANGLE_BETWEEN_CS

Category: Speed and accuracy

Use this advanced option to define the maximum angle between adjacent cross sections in curved polybeam segments. Enter the value in degrees. The default value is 30.0.

This advanced option works as a limiting factor to `XS_POLYBEAM_CHORD_TOLERANCE`.

This advanced option is model specific and the setting is saved in the options database.

See also

[XS_POLYBEAM_CHORD_TOLERANCE \(page 335\)](#)

17.22 XS_POLYBEAM_CURVATURE_TOLERANCE

Category

Modeling Properties

Use to define the tolerance used in detecting the curvature between three points in a polybeam. The default is $2.0e-6$.

This advanced option defines the difference in dot products between two unit vectors formed by two consecutive polybeam arc chamfer handles. If the dot product differs less than this value, the curve is considered to be a straight line, and the arc chamfer is omitted.

Generally, you need to change the default value only if you are working with long, thin or very complex polybeams. Change the default value in the following situations:

- If the polybeam is only very slightly curved and it looks like a straight polybeam in the model, you need to give a smaller value, such as $2.0e-10$. A larger value makes polybeams with only a slight curvature straight.
- If the value is unnecessarily small (smaller than default value for simple polybeams), there might be performance issues.
- If the tolerance is set to a value that is too small ($< e-11$), the polybeam may break.

17.23 XS_POLYGON_CUT_EXTRA_THICKNESS

Category

Modeling properties

Use this advanced option to define the cut depth of a polygon cut, for example, to cut thick surface treatment. The default value for the cut thickness is 5.0 mm.

17.24 XS_POLYGON_PERPENDICULAR_EDGE_PREFERENCE_FACTOR

Category: Plate work

NOTE If you change the value for this advanced option, run repair numbering to see the effect on drawings and **Document manager** list. The existing drawings might change.

This advanced option is used to artificially manipulate which side of a plate is considered as the 'longest'.

The longest side of polygon plates always faces downwards in drawings, which can affect plates with perpendicular edges.

This information can then be used, for example, in changing the rotation of a plate in drawings, or when choosing which side of a plate is to be considered the 'Length' and 'Width'.

This advanced option is used for plates with perpendicular sides in drawings. This advanced option rotates plates if there is some edge which is perpendicular to the current one and it is not adjacent edge.

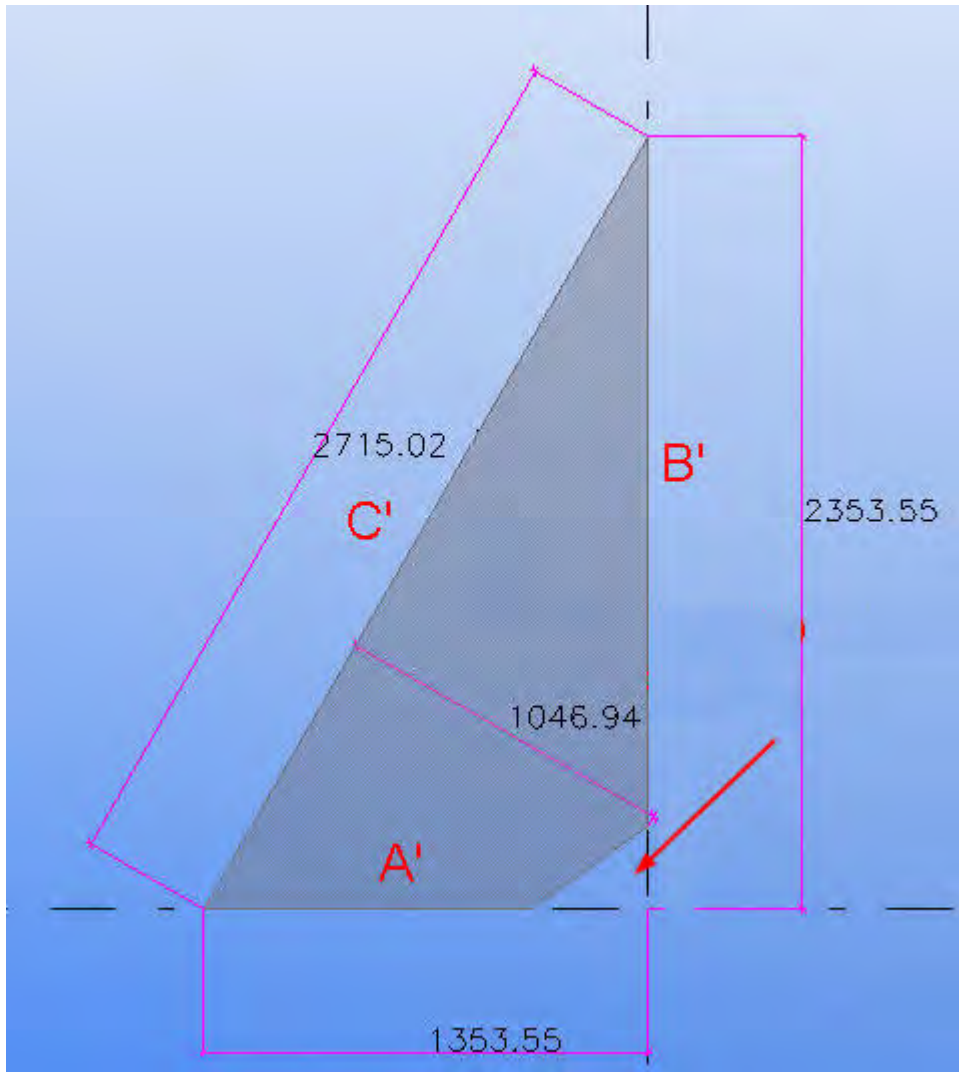

The default value is 1.5.

In the example above, when you set

`XS_POLYGON_PERPENDICULAR_EDGE_PREFERENCE_FACTOR` to 1, all sides are multiplied by 1, and view restriction box is drawn according to the longest side. The result is that the Length = 2715.02, and Width = 1046.94.

If you set this advanced option to 10, perpendicular corner edges A' and B' are multiplied by 10. If the result is larger than the longest side C', the view restriction box is drawn using the sides A' and B'. The result would be Length = 2353.55, and Width = 1353.55.

This advanced option is model specific and the setting is saved in the options database.

See also

[XS_POLYGON_SQUARE_CORNER_PREFERENCE_FACTOR](#) (page 339)

17.25 XS_POLYGON_SQUARE_CORNER_PREFERENCE_FACTOR

Category

Plate Work

This advanced option is used to artificially manipulate which side of a plate is considered as the 'longest'.

In drawings, this advanced option is also used to control the rotation of right-angled plates. The longest side of polygon plates always faces downwards in drawings, which can affect right-angled plates.

This information can then be used, for example, in changing the rotation of a plate in drawings, or when choosing which side of a plate is to be considered the 'Length' and 'Width'.

This advanced option is used for plates that have two consecutive edges perpendicular to each other. When this advanced option is set to a factor, Tekla Structures multiplies the length of the side next to the right angle by that factor, making it the longest side. In reports, this side will be then considered the 'Length', and the corresponding perpendicular distance the 'Width'.

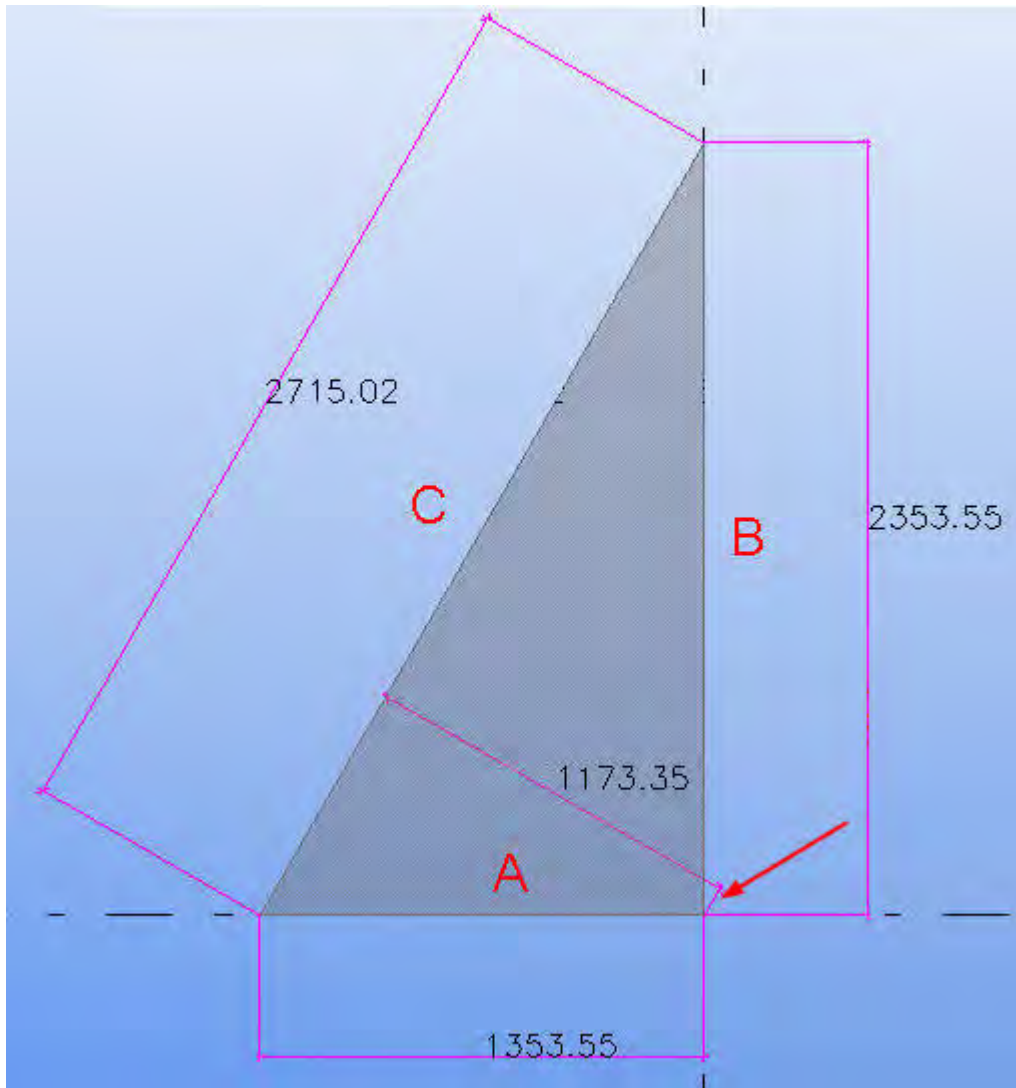

Tekla Structures still uses and displays the real dimensions of the plate.

In the example above, when you set

`XS_POLYGON_SQUARE_CORNER_PREFERENCE_FACTOR` to 1, all sides are multiplied by 1, and the view restriction box is drawn according to the longest side. The result is Length = 2715.02, and Width = 1173.35.

If you set this advanced option to 10, only square corner edges A and B are multiplied by 10. If the result is larger than the largest side C, the view restriction box is drawn using the sides A and B. The result would be Length = 2353.55, and Width = 1353.55.

The default value for this advanced option is 2.0.

This advanced option is model specific and the setting is saved in the options database.

See also

[XS_POLYGON_PERPENDICULAR_EDGE_PREFERENCE_FACTOR](#) (page 337)

17.26 XS_POP_MARK_COLOR

Category

Drawing Properties

Use to define the color of a customized pop-mark symbol that is displayed in a drawing. Enter an integer. The default value is 1 (white). Other possible values are:

| Value | Pop mark color |
|-------|----------------|
| 0 | Black |
| 2 | Red |
| 3 | Green |
| 4 | Blue |
| 5 | Cyan |
| 6 | Yellow |
| 7 | Magenta |

This advanced option is model specific and the setting is saved in the options database.

See also

[XS_POP_MARK_SYMBOL \(page 342\)](#)

[XS_POP_MARK_HEIGHT \(page 341\)](#)

17.27 XS_POP_MARK_HEIGHT

Category

Drawing Properties

Use to define the height of a customized pop-mark symbol that is displayed in a drawing. Enter a decimal value in millimeters. The default is 2.0.

This advanced option is model specific and the setting is saved in the options database.

See also

[XS_POP_MARK_SYMBOL \(page 342\)](#)

[XS_POP_MARK_COLOR \(page 341\)](#)

17.28 XS_POP_MARK_SYMBOL

Category

Drawing Properties

Use to define the customized pop-mark symbol to be used for pop-marks in drawings. The default is `xsteel@0`, which means that you are using symbol number 0 in the symbol file `xsteel`.



This advanced option is model specific and the setting is saved in the options database.

See also

[XS_POP_MARK_HEIGHT \(page 341\)](#)

[XS_POP_MARK_COLOR \(page 341\)](#)

17.29 XS_POSITION_DIMENSIONS_FOR_HOLES_IN_SINGLE_SECONDARY_PARTS_IN_ASSEMBLY_DRAWING

Category

Dimensioning: Bolts

To create position dimensions for holes in single secondary parts in assembly drawing, set this advanced option to `TRUE`. To not create position dimensions for holes, set it to `FALSE`. The default value is `TRUE`.

This advanced option is model specific and the setting is saved in the options database.

17.30 XS_POUR_BREAK_COLOR

Category: Concrete Detailing

Use this advanced option to change the color of pour breaks in model views. Enter number as the value using the class numbers in the part property pane

to indicate the color. For example, if you set this advanced option to 6, Tekla Structures will color all pour breaks yellow. The default value is 59.

In the exported IFC models, pour breaks are black.

This advanced option is user specific and the setting is saved in `options.bin` under the user folder, for example, in `C:\Users\\AppData\Local\Trimble\Tekla Structures\\UserSettings`. Restart Tekla Structures to activate the new value.

See also

[XS_POUR_OBJECT_COLOR](#) (page 343)

[XS_INVALID_POUR_BREAK_COLOR](#) (page 272)

17.31 XS_POUR_BREAK_SYMBOL

Category: Drawing properties

Pour breaks are represented by a symbol in the drawings, see the image below. The symbol scale and the spacing between the symbols follows the drawing view scale automatically.

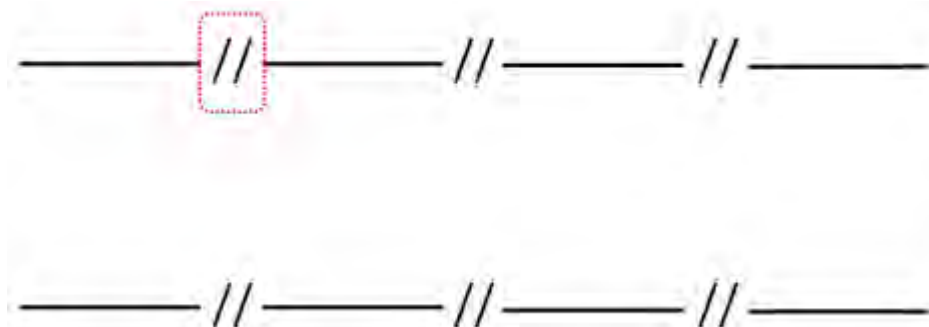

If you want to change the pour break symbol, enter a new value for this advanced option. The default value is `PourBreaks@0`. The symbol value starts with the symbol library file name and ends with the number of the symbol. The default library may contain many different pour break symbols. If you wish to use a symbol file that is not located under your environment folders, enter the complete path to the symbol file location and the symbol file name.

This advanced option is model specific and the setting is saved in the options database.

17.32 XS_POUR_OBJECT_COLOR

Category: Concrete Detailing

Use this advanced option to change the default color of pour objects in model views. Enter number as the value using the class numbers in the part property pane to indicate the color. For example, if you set this advanced option to 6, Tekla Structures will color all pour objects yellow.

This advanced option is user specific and the setting is saved in `options.bin` under the user folder, for example, in `C:\Users\\AppData\Local\Trimble\Tekla Structures\\UserSettings`. Restart Tekla Structures to activate the new value.

See also

[XS_POUR_BREAK_COLOR \(page 342\)](#)

17.33 XS_PREVIEW_LIMIT

Category: Model views

Use this advanced option to set the limit for number of objects shown in the copy or move preview. The preview is shown in the model when you use the **Copy** or **Move** command to copy or move objects.

The default value is 1000. When the value is 0, the preview is off.

17.34 XS_PRINT_MULTISHEET_BORDER

Category

Drawing Properties

Use to define the borders that are left out from the smaller sheets when printing a drawing on multiple small sheets.

For example, to leave a 3 mm horizontal and a 5 mm vertical border, set the advanced option to 3,5.

17.35 XS_PRINT_REPORT_FONT

Category

Templates and Symbols

Define the font for printed reports. Tekla Structures uses this advanced option if you do not specify another font for printed reports in the **Print** dialog box. The default value is `Arial Narrow`. If you do not enter a font, Tekla Structures uses the default font defined for `XS_DEFAULT_FONT`.

This advanced option is user specific and the setting is saved in `options.bin` under the user folder, for example, in `C:\Users\\AppData\Local\Trimble\Tekla Structures\\UserSettings`. Restart Tekla Structures to activate the new value.

17.36 XS_PRINT_REPORT_LINE_WIDTH_LANDSCAPE

Category

Templates and symbols

Use to specify the number of characters per row in reports printed in landscape orientation. The default value is 132.

This advanced option is model specific and the setting is saved in the options database.

See also

[XS_PRINT_REPORT_LINE_WIDTH_PORTRAIT](#) (page 345)

[XS_PRINT_REPORT_PAGE_HEIGHT_LANDSCAPE](#) (page 346)

[XS_PRINT_REPORT_PAGE_HEIGHT_PORTRAIT](#) (page 346)

17.37 XS_PRINT_REPORT_LINE_WIDTH_PORTRAIT

Category

Templates and symbols

Use to specify the number of characters per row in reports printed in portrait orientation. the default value is 80.

This advanced option is model specific and the setting is saved in the options database.

See also

[XS_PRINT_REPORT_LINE_WIDTH_LANDSCAPE](#) (page 345)

[XS_PRINT_REPORT_PAGE_HEIGHT_LANDSCAPE](#) (page 346)

[XS_PRINT_REPORT_PAGE_HEIGHT_PORTRAIT](#) (page 346)

17.38 XS_PRINT_REPORT_PAGE_HEIGHT_LANDSCAPE

Category**Templates and symbols**

Use to specify the number of rows in printed reports with landscape orientation. The default value is 42.

This advanced option is model specific and the setting is saved in the options database.

See also

[XS_PRINT_REPORT_LINE_WIDTH_LANDSCAPE](#) (page 345)

[XS_PRINT_REPORT_LINE_WIDTH_PORTRAIT](#) (page 345)

[XS_PRINT_REPORT_PAGE_HEIGHT_PORTRAIT](#) (page 346)

17.39 XS_PRINT_REPORT_PAGE_HEIGHT_PORTRAIT

Category**Templates and symbols**

Use to specify the number of rows in printed reports with portrait orientation. The default value is 62.

This advanced option is model specific and the setting is saved in the options database.

See also

[XS_PRINT_REPORT_LINE_WIDTH_LANDSCAPE](#) (page 345)

[XS_PRINT_REPORT_LINE_WIDTH_PORTRAIT](#) (page 345)

[XS_PRINT_REPORT_PAGE_HEIGHT_LANDSCAPE](#) (page 346)

17.40 XS_PRODUCT_IDENTIFIER

Category: Drawing View

To make it clear with which software a project has been modeled (old XSteel, other detailing systems or Tekla Structures) and reinforce the Tekla Structures brand, you can add a Tekla Structures product identifier to the side of every drawing. The product identifier will help promote the image of your company as a forward thinking company that uses the latest and most advanced technologies and techniques.

You can use the following values to change the position of the product identifier or turn it off: DX and DY offset, FALSE, and TRUE (default).

- If you do not want to use the product identifier, set this advanced option to FALSE.
- If you want to move the identifier, enter millimeter values separated by a comma (,) for both the X and Y directions.

For example, -5, 10 will move the text 5 millimeters to the left and 10 millimeters up.

This advanced option is model specific and the setting is saved in the options database.

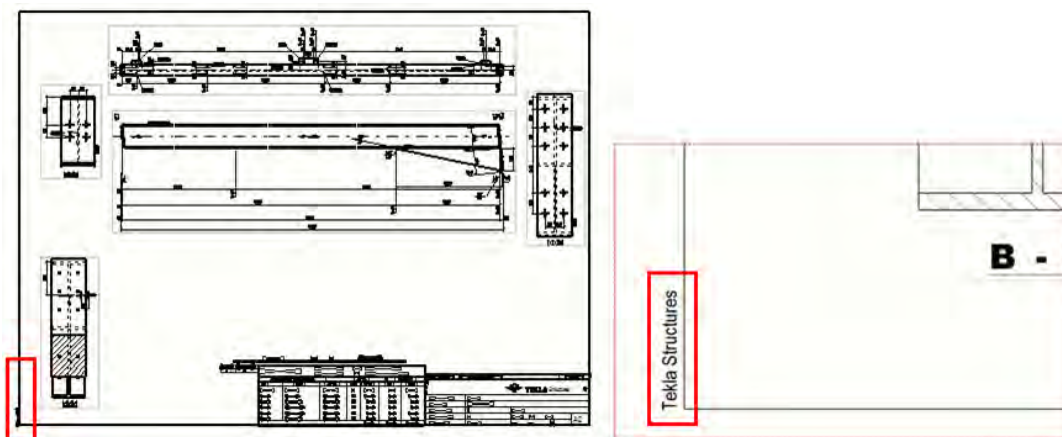

17.41 XS_PROFDB

Category

File Locations

Use to point to the profile folder which Tekla Structures searches for profile, material, device, and bolt catalogs.

You can store several catalogs in different locations, so it is important to know which catalog you are using.

This is a system-specific advanced option.

See also

17.42 XS_PROFILE_ANALYSIS_CHECK_ALL

Category: Analysis & Design

In the **Modify Profile Catalog** dialog box, you can enter analysis values for each profile. When you run the structural analysis, the analysis applications that use the COM link calculate the analysis values and compare them to the values in the Tekla Structures profile catalog. If the analysis application finds the values in the profile catalog, it uses the catalog values.

To check the profile catalog for analysis values for all profiles, enter `TRUE` for the following advanced options before you run the analysis:

- `XS_PROFILE_ANALYSIS_CHECK_ALL`
- `XS_AD_OPTIMISATION_DISABLED`

The default value is `FALSE`.

This advanced option is user specific and the setting is saved in `options.bin` under the user folder, for example, in `C:\Users\\AppData\Local\Trimble\Tekla Structures\\UserSettings`. Restart Tekla Structures to activate the new value.

If the profile catalog value differs significantly from the value the analysis application calculates, Tekla Structures writes a warning in the analysis log file. Use the advanced option `XS_PROFILE_ANALYSIS_VALUE_DIFF_LIMIT` to define the warning limit.

See also

[XS_PROFILE_ANALYSIS_VALUE_DIFF_LIMIT \(page 348\)](#)

[XS_AD_OPTIMISATION_DISABLED \(page 37\)](#)

17.43 XS_PROFILE_ANALYSIS_VALUE_DIFF_LIMIT

Category

Analysis & Design

Sets the warning limit as a percentage when checking profile catalog analysis values. The default value is 5.5 (%).

This advanced option is user specific and the setting is saved in `options.bin` under the user folder, for example, in `C:\Users\\AppData\Local\Trimble\Tekla Structures\\UserSettings`. Restart Tekla Structures to activate the new value.

See also

[XS_PROFILE_ANALYSIS_CHECK_ALL \(page 348\)](#)

17.44 XS_PROFILE_DISPLAY_INCH_MARK_AFTER_FRACTIONS_IN_REPORTS

Category

Imperial Units

Use to define the location of the inch mark in profile lengths in reports.

To display the inch mark after the fractions (for example, PL1"X18 1/2"), enter `TRUE`. To display the inch mark before the fractions (for example, PL1"X18"1/2), enter `FALSE`.

The inch mark is displayed after the fractions by default (`TRUE`).

This advanced option is user specific and the setting is saved in `options.bin` under the user folder, for example, in `C:\Users\\AppData\Local\Trimble\Tekla Structures\\UserSettings`. Restart Tekla Structures to activate the new value.

See also

[XSR_SHOW_INCH_MARK_IN_PROFILE_NAMES \(page 419\)](#)

17.45 XS_PROJECT

Category: File locations

NOTE This advanced option is only meant for administrators.

Set the advanced options `XS_PROJECT` and `XS_FIRM`, along with `XS_SYSTEM`, to point to the folders Tekla Structures searches for properties files. Tekla Structures always saves properties in the current `<model>\attributes` folder. You can then copy or move them to the `XS_FIRM` or the `XS_PROJECT` folders if the same settings are needed in other models. You can also create

user-defined sub-folders under the `XS_FIRM` and the `XS_PROJECT` folders, and copy or move property files from the `<model>\attributes` folder to these sub-folders.

For shared models, you can use a sub-folder in a Trimble Connect project as the project folder. For more information, see "Best practices for Tekla Model Sharing".

This advanced option is model specific and the setting is saved in the options database.

WARNING Changing an advanced option value in `.ini` files located outside the model folder does not affect the existing models. You can only update advanced options in the **Advanced Options** dialog box or in the `options.ini` file located in model folder; not from an `options.ini` file located in folders defined for the advanced options `XS_FIRM` or `XS_PROJECT`. The `.ini` files are read also when you open an existing model, but only new advanced options that do not exist in `options_model.db` or `options_drawings.db` are inserted, for example, such options that are not yet in the **Advanced Options** dialog box but have been added in the software.

17.46 XS_PROTECT_SYMBOLS

Category

Drawing Properties

Set this advanced option to `TRUE` to prevent Tekla Structures from drawing objects on top of symbols. If you set it to `FALSE`, symbols are not protected. The default value is `FALSE`.

This advanced option is model specific and the setting is saved in the options database.

18 Advanced options - R

18.1 XS_RADIUS_TEXT_IN_UNFOLDING_BENDING_LINE_DIMENSIONING

Category: Dimensioning: unfolding

Use to set prefix text for radii. Enter any text, for example, R=. By default there is no prefix for radius in bending line dimensioning

This advanced option is model specific and the setting is saved in the options database.

18.2 XSR_BOLT_LENGTH_USE_ONLY_INCHES

Category

Templates and symbols

Set this advanced option to `TRUE` to prevent the advanced option `XSR_USE_ZERO_FEET_VALUE` from affecting bolt length in bolt marks. If you want `XSR_USE_ZERO_FEET_VALUE` to affect bolt length in bolt marks, set it to `FALSE`. The default value is `FALSE`.

This advanced option is model specific and the setting is saved in the options database.

See also

[XSR_USE_ZERO_FEET_VALUE \(page 390\)](#)

18.3 XS_REBAR_BEND_MARK_SYMBOL_MIN_SIZE

Category: Concrete detailing

Use to increase the size of the reinforcing bar bend symbols in drawings (in drawing units) in order to see them more clearly. The default value is 1.

The value set for this advanced option is multiplied by the view scale. If the resulting value is bigger than the default size (diameter of the reinforcing bar), then it will be used as the symbol size. Otherwise the default value is used. This means that to make the symbol as small as possible, leave the value out or use zero (0).

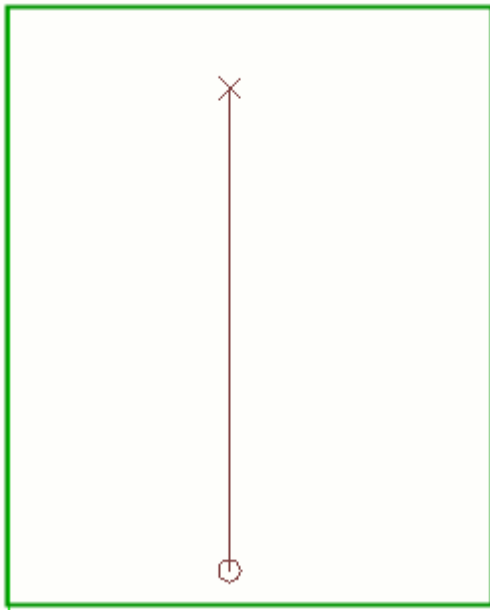

This advanced option can be used together with the advanced option `XS_REBAR_END_SYMBOL_MIN_SIZE`, which is used for increasing the size of the reinforcing bar end symbols.

This advanced option is model specific and the setting is saved in the options database.

See also

Define automatic reinforcement and mesh properties

[XS_REBAR_END_SYMBOL_MIN_SIZE](#) (page 353)

18.4 XS_REBAR_DIMENSION_LINE_SYMBOL

This advanced option must be set in an initialization (.ini) file. Add this advanced option in the `options.ini` file under model folder.

Use this advanced option to change the reinforcing bar group dimension (distribution) line symbol. You can create the dimension line by right-clicking the reinforcing bar group and selecting **Dimension mark**. The default value is `xsteel@16`, where `xsteel` is the name of the symbol file, and `16` is the running number of the symbol.

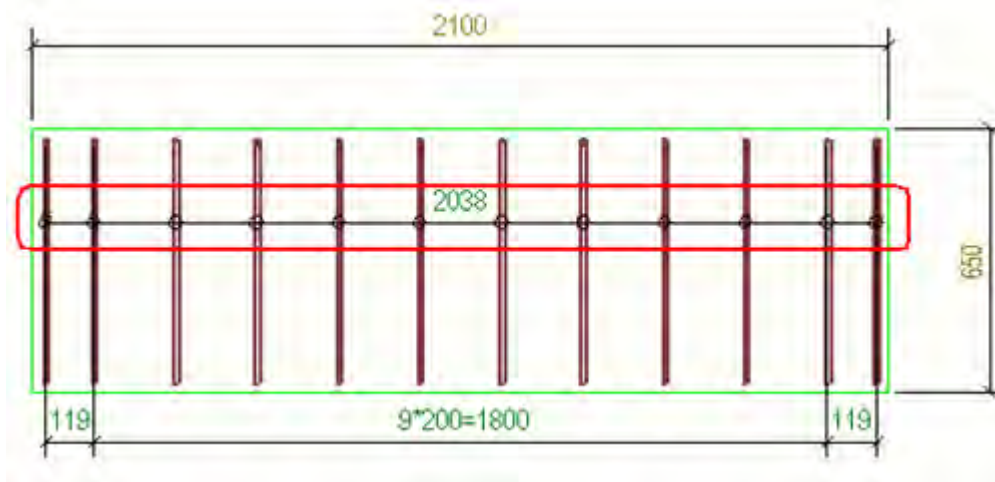

18.5 XS_REBAR_END_SYMBOL_MIN_SIZE

Category: Concrete detailing

Use to increase the size of the reinforcing bar end symbols in drawings (in drawing units) in order to see them more clearly. Works for 45 or 135 degree symbols. The default value is 2.

The value set for this advanced option is multiplied by the view scale. If the resulting value is bigger than the default size (diameter of the reinforcing bar), then it will be used as the symbol size. Otherwise the default value is used. This means that to make the symbol as small as possible, leave the value out or use zero (0).

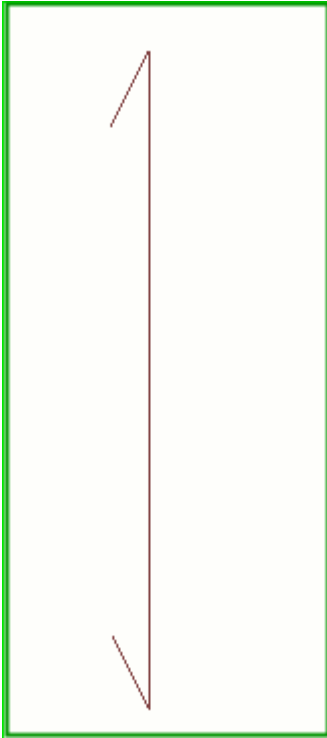

This advanced option can be used together with the advanced option `XS_REBAR_BEND_MARK_SYMBOL_MIN_SIZE`, which is used for increasing the size of the reinforcing bar bend symbols.

This advanced option is model specific and the setting is saved in the options database.

See also

[XS_REBAR_REVERSE_END_SYMBOLS](#) (page 360)

Define automatic reinforcement and reinforcement mesh properties

[XS_REBAR_BEND_MARK_SYMBOL_MIN_SIZE](#) (page 351)

18.6 XS_REBAR_GEOMETRY_TYPE_IN_NUMBERING

Category: Numbering

Use this advanced option to specify how the geometry of reinforcing bars is taken into account in numbering and which type of bar geometry is used when bars are compared with each other.

The options are:

- **POLYLINE:** The modeled, polyline geometry of bars is used in numbering. This is the default value.

Using this option means that the numbering of bars is unchanged from previous Tekla Structures versions (2023, 2022, and so on).

- **RATIONALIZED:** With the rationalized geometry, segmented arcs in bars are converted to true arcs in rebar shape recognition, and the true arcs are then used in numbering.

You can control the rationalization accuracy using the [Curve tolerance \(page 358\)](#) and [Extra point shortening \(page 358\)](#) settings.

Note that with the **RATIONALIZED** option the **Max curve radius requiring bending** settings and the **Recognize as straight bar** UDA are not taken into account in numbering. This means that bars with arcs might be treated differently in reporting and in numbering.

- **FABRICATION:** With the fabrication geometry that works on top of the rationalized geometry, arcs in bars might be recognized as straight legs in rebar shape recognition, depending on the [Max curve radius requiring bending \(page 359\)](#) settings. Bars that have the **Recognize as straight bar** UDA set to **Yes** are also recognized as straight.

With the **RATIONALIZED** or **FABRICATION** option, the simplified bar geometry is also used in cast unit numbering if the **Reinforcing bars** check box is selected in the **Numbering Setup** dialog box.

This advanced option is model specific and the setting is saved in the options database.

NOTE We do not recommend that you change this setting during a project. If you do so, you must clear the rebar position numbers and then number the bars again.

18.7 XS_REBAR_MARK_LEADER_LINE_BASE_POINT_SEARCH_STEP_LENGTH

Category

Concrete Detailing

Use to define the step length while searching for an optimal place for the rebar mark leader line base point along the reinforcing bar. Enter the value in millimeters using decimals. The default value is 20.0.

This advanced option is model specific and the setting is saved in the options database.

18.8 XS_REBAR_MARK_LEADER_LINE_BASE_POINT_SEARCH_TOLERANCE

Category

Concrete Detailing

Use to define how far the other reinforcing bars must be from the base point so that Tekla Structures can place the base point. Enter the value in millimeters using decimals. The default value is 10.0.

This advanced option is model specific and the setting is saved in the options database.

18.9 XS_REBAR_POSITION_NUMBER_FORMAT_STRING

Category: Numbering

Use to define the contents of the reinforcing bar position numbers. You can also change or remove the separator and affect how many numbers are used to represent the reinforcing bar position number. If you change the value, you need to renumber the model.

Use the following options or a combination of them:

| Option | Description |
|-----------------------|---|
| %PART_PREFIX% | The prefix of the position number of the part that contains the reinforcing bar. |
| %PART_START_NUMBER% | The start number of the position number of the part that contains the reinforcing bar. |
| %REBAR_PREFIX% | The prefix of the position number of the reinforcing bar. |
| %REBAR_SERIAL_NUMBER% | The position number without the prefix of the reinforcing bar. |
| %REBAR_POS% | This is no longer used. Use %REBAR_SERIAL_NUMBER% instead. |
| %REBAR_SIZE% | The size of the reinforcing bar with the possible size prefix. For example, in the US environments the size prefix is #. |
| %REBAR_SIZE_NUMBER% | The size of the reinforcing bar without the size prefix. |
| %CAST_UNIT_PREFIX% | The prefix of the position number of the cast unit that contains the reinforcing bar. |

| Option | Description |
|---------------------------------------|---|
| <code>%CAST_UNIT_START_NUMBER%</code> | The start number of the position number of the cast unit that contains the reinforcing bar. |

This advanced option is model specific and the setting is saved in the options database.

Example

In the reinforcing bar properties, the **Prefix** is set to `R`, the **Start number** is set to `1`, and the **Size** is set to `#6`.

- If you set the advanced option to `%REBAR_SIZE%%REBAR_PREFIX%REBAR_SERIAL_NUMBER.3%`, the result for the first reinforcing bar will be `#6R001`.
- If you set the advanced option to `%REBAR_SIZE_NUMBER%%REBAR_PREFIX%REBAR_SERIAL_NUMBER.3%` and number the model, the result for the first reinforcing bar is `6R001`.

18.10 XS_REBAR_PULLOUT_ANGLE_TEXT_FRAME

Category

Concrete Detailing

Use to turn off the text frame around the angle text in pull-out pictures. By default, this advanced option is set to `FALSE`, and no frame is drawn. If you set this advanced option to `TRUE`, the frame is drawn.

If you have set `XS_REBAR_PULLOUT_ANGLE_TEXT_UNDERLINE` to `TRUE`, then the advanced option `XS_REBAR_PULLOUT_ANGLE_TEXT_FRAME` is ignored.

This advanced option is model specific and the setting is saved in the options database.

See also

[XS_REBAR_PULLOUT_ANGLE_TEXT_UNDERLINE \(page 357\)](#)

18.11 XS_REBAR_PULLOUT_ANGLE_TEXT_UNDERLINE

Category

Concrete Detailing

Set this advanced option to `TRUE` to draw a line under the angle text in pull-outs. If you set it to `TRUE`, then the advanced option

`XS_REBAR_PULLOUT_ANGLE_TEXT_FRAME` is ignored. By default, this advanced option is set to `FALSE`, and no underline is drawn.

This advanced option is model specific and the setting is saved in the options database.

See also

[XS_REBAR_PULLOUT_ANGLE_TEXT_FRAME \(page 357\)](#)

18.12 XS_REBAR_RECOGNITION_CURVE_TOLERANCE

Category: Concrete detailing

Use this advanced option to set the default value for **Curve tolerance** that is used in rebar shape recognition.

You can use **Curve tolerance** to define whether multiple sequential bendings that are forming an arc in a reinforcing bar are combined into one or more bendings (90 degrees or less) with the arc radius as the bending radius.

If the deviation of a bar leg from the arc is less than the tolerance, bendings are combined.

If the deviation is more than the tolerance, or if **Curve tolerance** is set to 0, bendings are not combined.

The default value is 12.7 mm.

This advanced option is model specific and the setting is saved in the options database.

If needed, you can override this setting by modifying rebar definitions in the rebar catalog (`rebar_database.inp`) or by using the **Shape recognition** user-defined attributes of individual reinforcement objects.

See also

[XS_REBAR_RECOGNITION_EXTRA_POINT_SHORTENING \(page 358\)](#)

[XS_REBAR_RECOGNITION_MAXCURVE \(page 359\)](#)

18.13 XS_REBAR_RECOGNITION_EXTRA_POINT_SHORTENING

Category: Concrete detailing

Use this advanced option to set the default value for **Extra point shortening** that is used in rebar shape recognition.

Extra point shortening is used for defining whether two reinforcing bar legs ('1-2' and '2-3' in the image below) can be considered as one leg ('1-3').

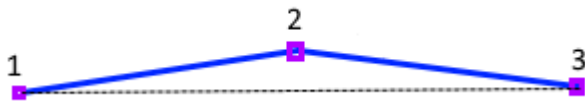

Define the maximum allowed difference between the distances '1-3' and '1-2' + '2-3'.

The default value is 0.3 mm. The maximum value that you can use is 2.56 mm.

This advanced option is model specific and the setting is saved in the options database.

If needed, you can override this setting by modifying rebar definitions in the rebar catalog (`rebar_database.inp`) or by using the **Shape recognition** user-defined attributes of individual reinforcement objects.

See also

[XS_REBAR_RECOGNITION_CURVE_TOLERANCE](#) (page 358)

[XS_REBAR_RECOGNITION_MAXCURVE](#) (page 359)

18.14 XS_REBAR_RECOGNITION_HOOKS_CONSIDERATION

Category

Concrete Detailing

Set to `FALSE` to have Tekla Structures ignore hooks when it checks the shape of reinforcing bars, and to have Tekla Structures assign the same bending type to bars with and without hooks.

Set to `TRUE` to have Tekla Structures take the hooks into account and to treat bars with or without hooks, or with different hooks, as different.

The default value is `TRUE`.

This advanced option is model specific and the setting is saved in the options database.

See also

18.15 XS_REBAR_RECOGNITION_MAXCURVE

Category: Concrete detailing

Use this advanced option to set the default value for **Max curve radius requiring bending** that is used in rebar shape recognition.

Max curve radius requiring bending sets the maximum inner radius of an arc leg. Arc legs that exceed this maximum radius are treated as straight legs and do not need to be prebent in fabrication. On site these straight legs will again take the form of an arc when the bars are fixed.

The default value is 304800 mm.

This advanced option is model specific and the setting is saved in the options database.

If needed, you can override this setting by modifying rebar definitions in the rebar catalog (`rebar_database.inp`) or by using the **Shape recognition** user-defined attributes of individual reinforcement objects.

The thicker the bars, the larger the **Max curve radius requiring bending** value should be. For thin bars that can be bent on site, the value can be smaller.

See also

[XS_REBAR_RECOGNITION_CURVE_TOLERANCE \(page 358\)](#)

[XS_REBAR_RECOGNITION_EXTRA_POINT_SHORTENING \(page 358\)](#)

18.16 XS_REBAR_REVERSE_END_SYMBOLS

Category: Concrete Detailing

Use to reverse the reinforcing bar end symbols to a different direction. When this advanced option is set to `TRUE`, the end symbol is drawn at 135 degree angle (used commonly in Norway). If you use single line visualization and no symbol at straight end, use the value `TRUEANDEXTEND`. If you use `TRUE` for these kinds of reinforcing bars, they will be drawn too short. The default value is `FALSE`.

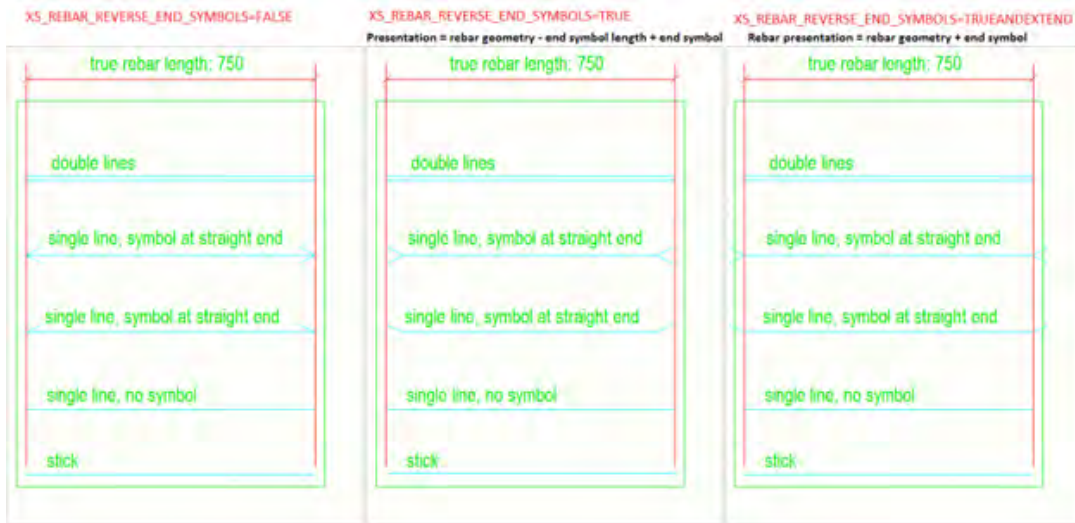

This advanced option is role specific. When the type **SYSTEM(ROLE)** is in use, the default value is used. When the type **MODEL(ROLE)** or **DRAWING(ROLE)** is in use, you can change the value, which is then the same for all users in the current model.

See also

[XS_REBAR_END_SYMBOL_MIN_SIZE](#) (page 353)

18.17 XS_REBARSET_BUFFER_SIZE

Category: Speed and accuracy

This advanced option defines the size of the memory cache used to store rebar set bars. When you increase the size, more rebar set bars can be kept in memory. This means that the rebar set bars are not regenerated so frequently, which will improve the performance. For optimum performance, the size should be greater or equal to the number of rebar set bars in the model.

This advanced option is user specific and the setting is saved in `options.bin` under the user folder, for example, in `C:\Users\\AppData\Local\Trimble\Tekla Structures\\UserSettings`. Restart Tekla Structures to activate the new value.

18.18 XS_REBARSET_COLOR_BARGROUPS

Category: Concrete detailing

Set this advanced option to `TRUE` to show bar groups within a rebar set using different colors in model views. For example:

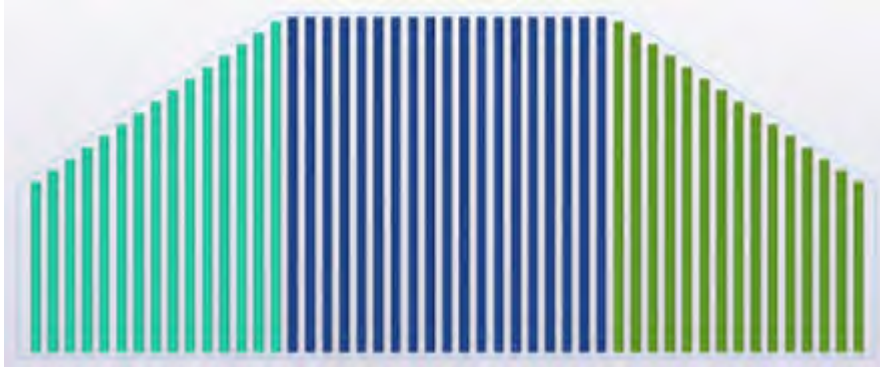

When you set this advanced option to `TRUE`, the reinforcing bars in rebar sets will not be colored by class.

The default value is `FALSE`.

This advanced option is model specific and the setting is saved in the options database.

After changing the setting of this advanced option in the **Advanced options** dialog box, redraw the model views.

TIP To quickly switch between the values `TRUE` and `FALSE`, go to the **Rebar** tab on the ribbon and click **Visibility** --> **Color groups**, or use the keyboard shortcut **Alt+7**.

18.19 XS_REBARSET_CREATION_ANGLE_TOLERANCE_FOR_CROSSING_REBARS

Category: Concrete detailing

Use this advanced option to define the tolerance for the angle between consecutive part faces when the rebar set bars are created. If the angle between a part face and the extension of the previous part face is less than the value of this advanced option, a rebar set leg face is created at the part face.

This advanced option applies to the rebar sets when they are created using the **Create crossing rebars** command. The default value is 45 (degrees).

This advanced option is model specific and the setting is saved in the options database.

See also

[XS_REBARSET_CREATION_ANGLE_TOLERANCE_FOR_LONGITUDINAL_REBARS](#)
(page 363)

18.20 XS_REBARSET_CREATION_ANGLE_TOLERANCE_FOR_LONGITUDINAL_REBARS

Category: Concrete detailing

Use this advanced option to define the tolerance for the angle between consecutive part faces when the rebar set bars are created. If the angle between a part face and the extension of the previous part face is less than the value of this advanced option, a rebar set leg face is created at the part face.

This advanced option applies to the rebar sets when they are created using the **Create longitudinal rebars** command. The default value is 45 (degrees).

This advanced option is model specific and the setting is saved in the options database.

See also

[XS_REBARSET_CREATION_ANGLE_TOLERANCE_FOR_CROSSING_REBARS](#)
(page 362)

18.21 XS_REBARSET_ENABLE_BAR_GROUPING_WHEN_SPACING_DIFFERS

Category: Concrete detailing

Use this advanced option to define whether spacing affects how reinforcing bars are grouped in rebar sets.

The default value is `TRUE`, which means that similar bars in adjacent spacing zones in a rebar set are grouped even when the spacing differs.

If this advanced option is set to `FALSE`, each spacing zone in a rebar set automatically creates a separate group.

This advanced option is model specific and the setting is saved in the options database.

After changing the setting of this advanced option, you need to update the existing rebar sets in the model. On the **Rebar** tab on the ribbon, click **More --> Regenerate** to activate the new setting.

18.22 XS_REBARSET_LEG_CONNECTION_TOLERANCE

Category: Concrete detailing

Use this advanced option to connect rebar set bar legs together even though the leg face edges do not overlap exactly. Define the maximum gap between the leg faces that are automatically connected. If the value is bigger than the existing gap, the gap is ignored and the bar legs are connected.

The default value is 1.0 mm.

This advanced option is model specific and the setting is saved in the options database.

After changing the value of this advanced option, you need to update the existing rebar sets in the model. On the **Rebar** tab on the ribbon, click **More --> Regenerate** to activate the new value.

18.23 XS_REBARSET_MINIMUM_BENDING_ANGLE

Category: Concrete detailing

Use this advanced option to control how small an angle is allowable between adjacent legs in a rebar set bar.

The default value is 0.1 degrees.

This advanced option is model specific and the setting is saved in the options database.

18.24 XS_REBARSET_MINIMUM_LEG_DEVIATION

Category: Concrete detailing

Use this advanced option to define whether rounding settings are applied to certain reinforcing bar legs in rebar sets or not.

Tekla Structures compares each bar leg to a straight line. If the deviation of a leg from the line is less than the value of this advanced option, the leg is considered to be a part of a curved bar segment and the leg length is not rounded.

If the deviation is more than the value of this advanced option, Tekla Structures considers the leg to be a straight bar segment and then rounds the leg length according to the rounding settings.

Enter the value in millimeters. The default value is 10.

This advanced option is model specific and the setting is saved in the options database.

18.25 XS_REBARSET_REBAR_LAYER_FORMAT_STRING

Category: Concrete detailing

Use this advanced option to define the contents of the template attribute LAYER.

The default value is %LAYER_PREFIX%%LAYER_NUMBER%, for example T2 for the second layer of top bars.

This advanced option is model specific and the setting is saved in the options database.

18.26 XS_REBARSET_ROUNDING_TOLERANCE

Category: Concrete detailing

Tekla Structures applies a rounding tolerance before rounding the leg lengths in rebar sets. Using a rounding tolerance prevents unnecessarily changing the bar dimensions when they are very close to a whole number. The tolerance is added to each leg length before the leg length is rounded down, or subtracted before rounding up.

Use this advanced option to modify the rounding tolerance. The default value is 0.001 mm.

This advanced option is model specific and the setting is saved in the options database.

After changing the value of this advanced option, update the existing rebar sets in the model. Reopen the model, or on the **Rebar** tab on the ribbon, click **More** --> **Regenerate** to activate the new value. The leg lengths of existing rebar set bars might change.

Example

The original leg lengths of a bar are 929.98 mm and 324.60 mm before rounding, and the rounding setting is **Down** 5 mm for the leg lengths.

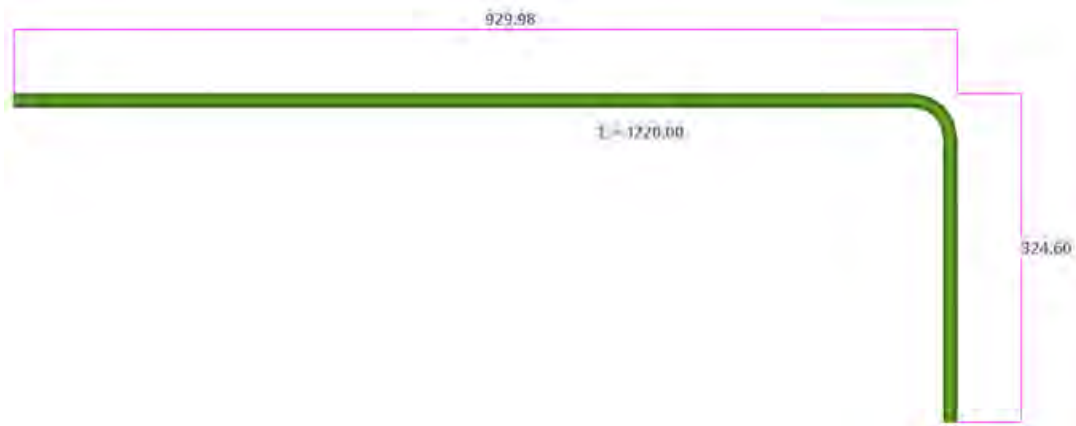

- If the rounding tolerance is 0.001, the leg lengths are rounded down to 925 and 320.
- If the rounding tolerance is 0.5, the leg lengths are rounded to 930 and 325. These whole numbers are used because the difference from the original leg lengths is less than the rounding tolerance.

18.27 XS_REBARSET_SHOW_END_DETAIL_MODIFIERS

Category: Concrete detailing

Set this advanced option to `TRUE` to show the rebar set end detail modifiers when you select rebar set bars in the model.

If this advanced option is set to `FALSE`, end detail modifiers are not shown when you select rebar set bars.

The default value is `TRUE`.

This advanced option is model specific and the setting is saved in the options database.

TIP To quickly switch between the values `TRUE` and `FALSE`, go to the **Rebar** tab on the ribbon and click **Visibility** --> **End detail modifiers**, or use the keyboard shortcut **Alt+5**.

See also

[XS_REBARSET_SHOW_PROPERTY_MODIFIERS](#) (page 368)

[XS_REBARSET_SHOW_SPLITTERS](#) (page 369)

[XS_REBARSET_SHOW_GUIDELINES \(page 367\)](#)

[XS_REBARSET_SHOW_MODIFIERS_CREATED_BY_COMPONENTS \(page 368\)](#)

18.28 XS_REBARSET_SHOW_GUIDELINES

Category: Concrete detailing

Set this advanced option to `TRUE` to show the rebar set guidelines when you select rebar set bars in the model.

If this advanced option is set to `FALSE`, rebar set guidelines are not shown when you select rebar set bars.

The default value is `TRUE`.

This advanced option is model specific and the setting is saved in the options database.

TIP To quickly switch between the values `TRUE` and `FALSE`, go to the **Rebar** tab on the ribbon and click **Visibility** --> **Guidelines**, or use the keyboard shortcut **Alt+2**.

See also

[XS_REBARSET_SHOW_PROPERTY_MODIFIERS \(page 368\)](#)

[XS_REBARSET_SHOW_END_DETAIL_MODIFIERS \(page 366\)](#)

[XS_REBARSET_SHOW_SPLITTERS \(page 369\)](#)

[XS_REBARSET_SHOW_MODIFIERS_CREATED_BY_COMPONENTS \(page 368\)](#)

18.29 XS_REBARSET_SHOW_LEGFACES

Category: Concrete detailing

Set this advanced option to `TRUE` to show the rebar set leg faces and leg surfaces when you select rebar set bars in the model.

If this advanced option is set to `FALSE`, leg faces and leg surfaces are not shown when you select rebar set bars.

The default value is `FALSE`.

This advanced option is model specific and the setting is saved in the options database.

TIP To quickly switch between the values `TRUE` and `FALSE`, go to the **Rebar** tab on the ribbon and click **Visibility** --> **Leg faces**, or use the keyboard shortcut **Alt+1**.

18.30 XS_REBARSET_SHOW_MODIFIERS_CREATED_BY_COMPONENTS

Category: Concrete detailing

Use this advanced option to control whether the rebar set modifiers that are created by components are shown or hidden in model views when you select rebar set bars.

The default value is `FALSE`, which means that the modifiers are hidden.

Note that if you explode a component that has modifiers, the modifiers will be shown even if this advanced option is set to `FALSE`.

This advanced option does not affect the custom component views.

This advanced option is model specific and the setting is saved in the options database.

18.31 XS_REBARSET_SHOW_PROPERTY_MODIFIERS

Category: Concrete detailing

Set this advanced option to `TRUE` to show the rebar set property modifiers when you select rebar set bars in the model.

If this advanced option is set to `FALSE`, property modifiers are not shown when you select rebar set bars.

The default value is `TRUE`.

This advanced option is model specific and the setting is saved in the options database.

TIP To quickly switch between the values `TRUE` and `FALSE`, go to the **Rebar** tab on the ribbon and click **Visibility** --> **Property modifiers**, or use the keyboard shortcut **Alt+3**.

See also

[XS_REBARSET_SHOW_END_DETAIL_MODIFIERS \(page 366\)](#)

[XS_REBARSET_SHOW_SPLITTERS \(page 369\)](#)

[XS_REBARSET_SHOW_GUIDELINES \(page 367\)](#)

[XS_REBARSET_SHOW_MODIFIERS_CREATED_BY_COMPONENTS \(page 368\)](#)

18.32 XS_REBARSET_SHOW_SPLITTERS

Category: Concrete detailing

Set this advanced option to `TRUE` to show the rebar set splitters when you select rebar set bars in the model.

If this advanced option is set to `FALSE`, splitters are not shown when you select rebar set bars.

The default value is `TRUE`.

This advanced option is model specific and the setting is saved in the options database.

TIP To quickly switch between the values `TRUE` and `FALSE`, go to the **Rebar** tab on the ribbon and click **Visibility** --> **Splitters**, or use the keyboard shortcut **Alt+4**.

See also

[XS_REBARSET_SHOW_PROPERTY_MODIFIERS \(page 368\)](#)

[XS_REBARSET_SHOW_END_DETAIL_MODIFIERS \(page 366\)](#)

[XS_REBARSET_SHOW_GUIDELINES \(page 367\)](#)

[XS_REBARSET_SHOW_MODIFIERS_CREATED_BY_COMPONENTS \(page 368\)](#)

18.33 XS_REBARSET_SIMILAR_GROUPING_NUMBER

Category: Concrete detailing

Use this advanced option to define the minimum number of similar rebar set bars that can be automatically grouped.

The default value is 3.

This advanced option is model specific and the setting is saved in the options database.

After changing the value of this advanced option, you need to update the existing rebar sets in the model. On the **Rebar** tab on the ribbon, click **More -- > Regenerate** to activate the new value.

If you need to override the value of this advanced option in certain rebar sets, enter a value for **Minimum number of bars in similar group** in the rebar set or property modifier user-defined attributes.

See also

[XS_REBARSET_SIMILAR_GROUPING_TOLERANCE \(page 370\)](#)

18.34 XS_REBARSET_SIMILAR_GROUPING_TOLERANCE

Category: Concrete detailing

Use this advanced option to define which similar rebar set bars can be automatically grouped. Define the maximum allowed difference in the geometry of the bars that will be grouped.

The default value is 1.0 mm.

This advanced option is model specific and the setting is saved in the options database.

After changing the value of this advanced option, you need to update the existing rebar sets in the model. On the **Rebar** tab on the ribbon, click **More -- > Regenerate** to activate the new value.

See also

[XS_REBARSET_TAPERED_LINEAR_GROUPING_TOLERANCE \(page 372\)](#)

[XS_REBARSET_TAPERED_CURVED_GROUPING_TOLERANCE \(page 370\)](#)

[XS_REBARSET_SIMILAR_GROUPING_NUMBER \(page 369\)](#)

18.35 XS_REBARSET_TAPERED_CURVED_GROUPING_TOLERANCE

Category: Concrete detailing

Use this advanced option to define which rebar set bars can automatically form a tapered bar group that follows a curve. Either one end or both ends of the grouped bars can follow a curve. Define the maximum allowed distance of the bar ends from the curve.

The default value is 10 mm.

This advanced option is model specific and the setting is saved in the options database.

After changing the value of this advanced option, you need to update the existing rebar sets in the model. On the **Rebar** tab on the ribbon, click **More** --> **Regenerate** to activate the new value.

If you need to override the value of this advanced option in certain rebar sets, enter a value for **Tapered curved tolerance** in the rebar set or property modifier user-defined attributes.

See also

[XS_REBARSET_TAPERED_LINEAR_GROUPING_TOLERANCE \(page 372\)](#)

[XS_REBARSET_SIMILAR_GROUPING_TOLERANCE \(page 370\)](#)

18.36 XS_REBARSET_TAPERED_GROUP_POSITION_NUMBER_FORMAT_STRING

Category: Numbering

Use this advanced option to define the contents of the reinforcement position numbers (GROUP_POS) in tapered bar groups within rebar sets. You can also change or remove the separator and affect how many numbers are used to represent the position number. If you change the value, you need to renumber the model.

Use the following options or a combination of them:

| Option | Description |
|-----------------------|---|
| %PART_PREFIX% | The prefix of the position number of the part that contains the reinforcing bar. |
| %PART_START_NUMBER% | The start number of the position number of the part that contains the reinforcing bar. |
| %REBAR_PREFIX% | The prefix of the position number of the reinforcing bar. |
| %REBAR_SERIAL_NUMBER% | The position number without the prefix of the reinforcing bar. |
| %REBAR_POS% | This is no longer used. Use %REBAR_SERIAL_NUMBER% instead. |
| %REBAR_SIZE% | The size of the reinforcing bar with the possible size prefix. For example, in the US environments the size prefix is #. |

| Option | Description |
|--------------------------|---|
| %REBAR_SIZE_NUMBER% | The size of the reinforcing bar without the size prefix. |
| %CAST_UNIT_PREFIX% | The prefix of the position number of the cast unit that contains the reinforcing bar. |
| %CAST_UNIT_START_NUMBER% | The start number of the position number of the cast unit that contains the reinforcing bar. |

The default value is %REBAR_PREFIX%%REBAR_SERIAL_NUMBER%.

This advanced option is model specific and the setting is saved in the options database.

Example

The **Prefix** in the rebar set properties is set to R, the **Start number** is set to 1, and the **Size** is set to #6.

- If you set the advanced option to %REBAR_SIZE%%REBAR_PREFIX%%REBAR_SERIAL_NUMBER.3%, the result for the first reinforcing bar will be #6R001.
- If you set the advanced option to %REBAR_SIZE_NUMBER%%REBAR_PREFIX%%REBAR_SERIAL_NUMBER.3% and number the model, the result for the first reinforcing bar is 6R001.

See also

[XS_REBARSET_TAPERED_REBAR_POSITION_NUMBER_FORMAT_STRING](#)
(page 373)

18.37 XS_REBARSET_TAPERED_LINEAR_GROUPING_TOLERANCE

Category: Concrete detailing

Use this advanced option to define which rebar set bars can automatically form a tapered bar group that follows a line. Define the maximum allowed distance of the bar ends from the line.

The default value is 0.5 mm.

This advanced option is model specific and the setting is saved in the options database.

After changing the value of this advanced option, you need to update the existing rebar sets in the model. On the **Rebar** tab on the ribbon, click **More --> Regenerate** to activate the new value.

If you need to override the value of this advanced option in certain rebar sets, enter a value for **Tapered linear tolerance** in the rebar set or property modifier user-defined attributes.

See also

[XS_REBARSET_TAPERED_CURVED_GROUPING_TOLERANCE \(page 370\)](#)

[XS_REBARSET_SIMILAR_GROUPING_TOLERANCE \(page 370\)](#)

18.38 XS_REBARSET_TAPERED_REBAR_POSITION_NUMBER_FORMAT_STRING

Category: Numbering

Use this advanced option to define the contents of the reinforcement position numbers (REBAR_POS) of single bars in tapered bar groups within rebar sets. You can also change or remove the separator and affect how many numbers are used to represent the position number. If you change the value, you need to renumber the model.

Use the following options or a combination of them:

| Option | Description |
|-----------------------|---|
| %PART_PREFIX% | The prefix of the position number of the part that contains the reinforcing bar. |
| %PART_START_NUMBER% | The start number of the position number of the part that contains the reinforcing bar. |
| %REBAR_PREFIX% | The prefix of the position number of the reinforcing bar. |
| %REBAR_SERIAL_NUMBER% | The position number without the prefix of the reinforcing bar. |
| %REBAR_POS% | This is no longer used. Use %REBAR_SERIAL_NUMBER% instead. |
| %REBAR_SIZE% | The size of the reinforcing bar with the possible size prefix. For example, in the US environments the size prefix is #. |
| %REBAR_SIZE_NUMBER% | The size of the reinforcing bar without the size prefix. |
| %CAST_UNIT_PREFIX% | The prefix of the position number of the cast unit that contains the reinforcing bar. |

| Option | Description |
|--------------------------|--|
| %CAST_UNIT_START_NUMBER% | The start number of the position number of the cast unit that contains the reinforcing bar. |
| %SUB_ID% | The running index number of the reinforcing bar in a tapered bar group within a rebar set. |
| %SUB_ID_WITH_LETTERS% | Same as above, but with letters. Uses letters A-Z by default, but you can also define the valid letters with the advanced option XS_VALID_CHARS_FOR_REBAR_SUB_ID_WITH_LETTERS (page 502). |

The default value is %REBAR_PREFIX%%REBAR_SERIAL_NUMBER%.%SUB_ID%.

This advanced option is model specific and the setting is saved in the options database.

Example

The **Prefix** in the rebar set properties is set to R, the **Start number** is set to 1, and the **Size** is set to #6.

- If you set the advanced option to %REBAR_SIZE%%REBAR_PREFIX%%REBAR_SERIAL_NUMBER%.3%, the result for the first reinforcing bar will be #6R001.
- If you set the advanced option to %REBAR_SIZE_NUMBER%%REBAR_PREFIX%%REBAR_SERIAL_NUMBER%.3% and number the model, the result for the first reinforcing bar is 6R001.

See also

[XS_REBARSET_TAPERED_GROUP_POSITION_NUMBER_FORMAT_STRING](#)
(page 371)

18.39 XS_REBARSET_USE_GROUP_NUMBER_FOR_BARS_IN_TAPERED_GROUPS

Category: Numbering

Use this advanced option to define whether reinforcing bars in tapered bar groups within rebar sets are numbered using their group numbers, or as individual bars.

The default value is `TRUE`, which means that each bar in a tapered bar group is numbered using the group number.

If this advanced option is set to `FALSE`, bars in tapered bar groups are numbered as individual bars.

This advanced option is model specific and the setting is saved in the options database.

See also

[XS_REBARSET_TAPERED_GROUP_POSITION_NUMBER_FORMAT_STRING](#)
(page 371)

[XS_REBARSET_TAPERED_REBAR_POSITION_NUMBER_FORMAT_STRING](#)
(page 373)

18.40 XS_REBAR_USE_ALWAYS_METHOD_A_FOR_90_DEGREE_HOOK_DIMENSIONS

This advanced option must be set in an initialization (.ini) file.

When set to `TRUE`, the **SHLB/EHLB** hook properties will have the same values as the **SHLA/EHLA** properties in case the hook angle is approximately 95 degrees or less.

18.41 XS_RECREATE_MARKS_IN_INTELLIGENT_CLONING

Category

Marking: General

Set this advanced option to `ALL` to recreate all marks during intelligent cloning. If you leave the value out, marks are not recreated. By default, no value is set.

This advanced option is model specific and the setting is saved in the options database.

18.42 XS_RECREATE_UNMODIFIED_DRAWINGS

Category: Drawing Properties

Use to define whether drawings are recreated when you update an assembly, single or cast unit drawing that has not been modified. Drawings are automatically recreated unless they have been edited and then saved, or they have been issued using the **Issue** functionality in **Document manager**.

- To prevent the recreation of the unmodified drawings, set the advanced option `FALSE`.
- To allow the recreation of the unmodified drawings, set the advanced option to `TRUE`. This is the default value.

This advanced option is user specific and the setting is saved in `options.bin` under the user folder, for example, in `C:\Users\\AppData\Local\Trimble\Tekla Structures\\UserSettings`. Restart Tekla Structures to activate the new value.

18.43 XS_REFERENCE_CACHE

Category

File Locations

Use to define the default location of the cache file that is created from the source file when you load a reference model for the first time. The advanced option is set to `C:\TeklaStructuresModels\RefCacheFolders` by default. You can also replace the path with `XS_RUNPATH` as follows:

```
%XS_RUNPATH%\RefCacheFolders.
```

-
- TIP** • You may sometimes want to change the default location of the cache file when you are working with multi-user models to reduce network traffic and disk usage in the server or to speed up the cache operation (if the local drive is faster than the server drive).
- When you are using different versions of Tekla Structures for different projects and you experience problems with reference models, empty the folder where the reference cache is created. The cache file is recreated the next time you open the reference model.

This advanced option is user specific and the setting is saved in `options.bin` under the user folder, for example, in `C:\Users\\AppData\Local\Trimble\Tekla Structures\\UserSettings`. Restart Tekla Structures to activate the new value.

18.44 XS_REFERENCE_MODEL_KEEP_VERSIONS_COUNT

Category: Modeling Properties

Use the `XS_REFERENCE_MODEL_KEEP_VERSIONS_COUNT` advanced option to clean up old reference model revisions automatically. The cleanup is done when the reference file is updated. Use

[XS_DELETE_UNNECESSARY_REFMODEL_FILES_SAFETY_PERIOD](#) (page 121)

to set the time frame for deletion. Tekla Structures deletes the reference models that have been imported at some point but are no longer used, and are not displayed in the **Reference Models** list. The data related to these reference models is deleted from the current data storage in folder `<current model>\datastorage\ref`. The original imported reference model is not deleted from its actual folder, for example, from `.\Reference models`.

You can use the following values:

- 0: The cleanup is disabled. This is the default value.
- Any positive number.

For example, value 3 keeps two old revisions of the reference model, in addition to the current version.

This advanced option is model specific and the setting is saved in the options database.

18.45 XS_REFERENCE_USE_RENDERED_CLIPPING

Category

Import

Set to `TRUE` to have Tekla Structures show only the center line of reference objects outside the work area in model views. This can be useful, for example, when viewing cylindrical DGN structures, such as piping. If you do not want to show only center line, set it to `FALSE`. The default value is `TRUE`. |

Tekla Structures then shows the objects as follows:

- Objects entirely inside work area are rendered.
- Objects entirely outside work area are hidden.
- Objects partly inside the work area are rendered inside work area, and wireframe outside work area.

This advanced option is user specific and the setting is saved in `options.bin` under the user folder, for example, in `C:\Users\<user>\AppData\Local\Trimble\Tekla Structures\<version>\UserSettings`. Restart Tekla Structures to activate the new value.

18.46 XS_REFRESH_ALSO_LOCKED_REFERENCE_MODELS

Category: Import

Set the advanced option `XS_REFRESH_ALSO_LOCKED_REFERENCE_MODELS` to `TRUE` to refresh locked reference models with the **Refresh** button . This advanced option is by default set to `FALSE`.

This advanced option is system specific.

18.47 XS_REMEMBER_LAST_PLOT_DIALOG_VALUES

Category

This advanced option must be set in an initialization (.ini) file.

If you set this advanced option to `TRUE`, Tekla Structures remembers the latest settings that were used in the **Print Drawings** dialog box when you open the dialog box the next time. If you do not want to do this, enter `false`. The default value is `TRUE`.

18.48 XS_REMOVE_VOID_FROM_BOLT_MATERIAL_THICKNESS

Category: Modeling Properties

Set this advanced option to `TRUE` to remove the gap between two bolted material thicknesses, resulting in a shorter bolt length. This is required by, for example, mast builders. The default value is `FALSE`.

In the example below, the advanced option is set to `TRUE`. The value "X" will be removed from the bolt length.

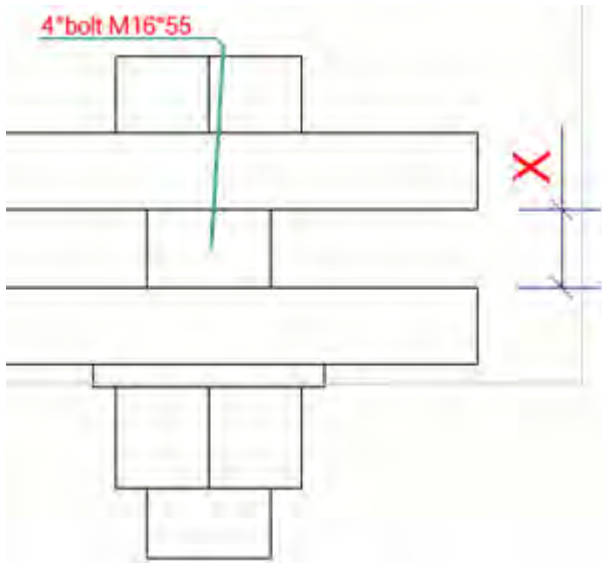

This advanced option is model specific and the setting is saved in the options database.

18.49 XS_RENDERED_CURSOR_LINE_WIDTH

Category

Model View

Use to set cursor line width in model views.

- Possible values are 1, 2, or 4. Any other value is handled as 1.
- The default value is 2.

This advanced option is user specific and the setting is saved in `options.bin` under the user folder, for example, in `C:\Users\\AppData\Local\Trimble\Tekla Structures\\UserSettings`. Restart Tekla Structures to activate the new value.

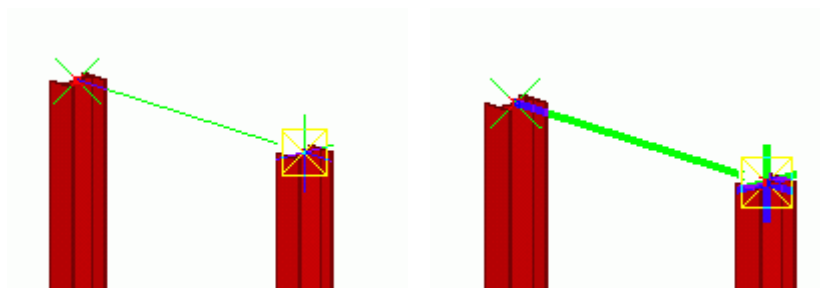

Cursor line width of 1

Cursor line width of 4

18.50 XS_RENDERED_FIELD_OF_VIEW

Category

Model View

Use to adjust the field of view setting in perspective views. This can be useful, for example, when using the **Fly** command in a tight space. The bigger the value, the more distance there is between the parts.

The default value is 60.0.

This advanced option is user specific and the setting is saved in `options.bin` under the user folder, for example, in `C:\Users\<user>\AppData\Local\Trimble\Tekla Structures\<version>\UserSettings`. Restart Tekla Structures to activate the new value.

Example

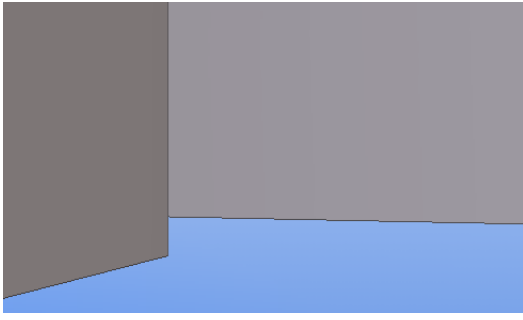
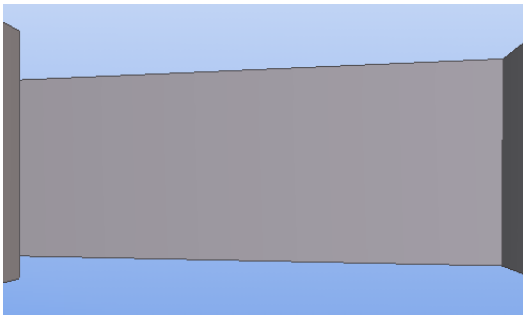
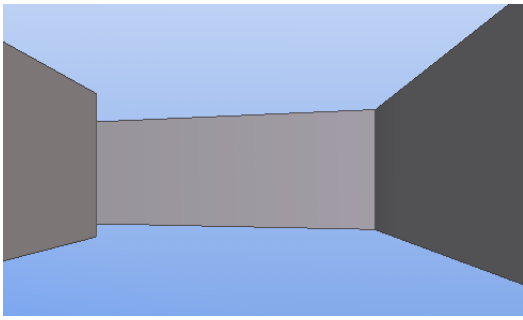
| Field of view | Example |
|---------------|--|
| 60.0 |  A perspective view of a room with a blue floor and grey walls. The field of view is narrow, showing a close-up of the corner. |
| 90.0 |  A perspective view of a room with a blue floor and grey walls. The field of view is wider, showing more of the room's depth. |
| 120.0 |  A perspective view of a room with a blue floor and grey walls. The field of view is very wide, showing a large portion of the room and the walls. |

18.51 XS_RENDERED_GL_FOG_END_VALUE

Category

Model View

Note that this advanced option works only in views that use OpenGL rendering.

In model views, the distant objects appear progressively darker than the close ones. Use the advanced options `XS_RENDERED_GL_FOG_START_VALUE` and `XS_RENDERED_GL_FOG_END_VALUE` to control the shade of objects.

Use values from 0.0 to 1.0 to control the shade of objects. The higher the value, the darker the distant objects. Value 0 disables the fog effect. The default value for `XS_RENDERED_GL_FOG_END_VALUE` is 0.

This advanced option is user specific and the setting is saved in `options.bin` under the user folder, for example, in `C:\Users\\AppData\Local\Trimble\Tekla Structures\\UserSettings`. Restart Tekla Structures to activate the new value.

See also

[XS_RENDERED_GL_FOG_START_VALUE](#) (page 381)

18.52 XS_RENDERED_GL_FOG_START_VALUE

Category

Model View

Note that this advanced option works only if you use the default OpenGL rendering instead of the DirectX rendering.

In model views, the distant objects appear progressively darker than the close ones. Use the advanced options `XS_RENDERED_GL_FOG_START_VALUE` and `XS_RENDERED_GL_FOG_END_VALUE` to control the shade of objects.

Use values from 0.0 to 1.0 to control the shade of objects. The higher the value, the darker the distant objects. Value 0 disables the fog effect. The default value for `XS_RENDERED_GL_FOG_START_VALUE` is 0.

This advanced option is user specific and the setting is saved in `options.bin` under the user folder, for example, in `C:\Users\\AppData\Local\Trimble\Tekla Structures\\UserSettings`. Restart Tekla Structures to activate the new value.

See also

[XS_RENDERED_GL_FOG_END_VALUE \(page 381\)](#)

18.53 XS_RENDERED_PIXEL_TOLERANCE_SCALE

Category

Model View

Tekla Structures uses pixel tolerance to differentiate between clicking and dragging the mouse when zooming. Use this advanced option to define the pixel tolerance.

The default value is 0.7. If the mouse moves less than the specified value while the left mouse button is pressed down, it is treated as a click.

This is a system-specific advanced option.

18.54 XS_REPORT_BOLTS_WITH_SUPPORTING_MEMBER

Category: Templates and symbols

You can set the site bolts to the supporting member in reports and KSS by setting the advanced option `XS_REPORT_BOLTS_WITH_SUPPORTING_MEMBER` to `TRUE`. Using this advanced option you can show the field bolts in the BOM of the supporting member. The default value is `FALSE`.

In the following BOM example, the advanced option is set to `TRUE`:



In the following BOM example, the advanced option is set to `FALSE`:



In the following KSS file example, the advanced option is set to `TRUE`:

```
MIS_list_TRUE.kss - Notepad
File Edit Format View Help
KISS,1.0,Tekla Structures
H,PROJ-NUM,PROJ-NAME,,11/28/16,09:44,F
*
D,B1,,B1,B1,1,w,21X44,A992,13265.15,,BEAM
L,Holes,8,20.64,9.53,Round
S,1,1
*
D,C1,,C1,C1,1,w,16X89,A992,6686.55,,COLUMN
L,Weld,1,18/9.60,6.35,w10
L,Weld,2,304.80,4.76,w10
D,C1,,C1,BP2,1,PL,3/4X26,A36,660.40,,PLATE
L,Holes,4,26.99,0.00,Round
S,1,1
D,C1,,C1,p7,1,FL,3/8X3-1/2,A36,304.80,,PLATE
L,Holes,4,20.64,9.53,Slotted
D,C1,,C1,,4,HS,3/4X2,A325,50.80,,Field
*
D,C2,,C2,C2,1,w,16X89,A992,6686.55,,COLUMN
L,Weld,1,18/9.60,6.35,w10
L,Weld,2,304.80,4.76,w10
D,C2,,C2,BP2,1,PL,3/4X26,A36,660.40,,PLATE
L,Holes,4,26.99,0.00,Round
S,1,1
D,C2,,C2,p7,1,FL,3/8X3-1/2,A36,304.80,,PLATE
L,Holes,4,20.64,9.53,Slotted
D,C2,,C2,,4,HS,3/4X2,A325,50.80,,Field
```

In the following KSS file example, the advanced option is set to FALSE:

```
MIS_list_FALSE.kss - Notepad
File Edit Format View Help
KISS,1.0,Tekla Structures
H,PROJ-NUM,PROJ-NAME,,11/28/16,09:40,F
*
D,B1,,B1,B1,1,w,21X44,A992,13265.15,,BEAM
L,Holes,8,20.64,9.53,Round
D,B1,,B1,,8,HS,3/4X2,A325,50.80,,Field
S,1,1
*
D,C1,,C1,C1,1,w,16X89,A992,6686.55,,COLUMN
L,Weld,1,1879.60,6.35,w10
L,Weld,2,304.80,4.76,w10
D,C1,,C1,BP2,1,PL,3/4X26,A36,660.40,,PLATE
L,Holes,4,26.99,0.00,Round
S,1,1
D,C1,,C1,p7,1,FL,3/8X3-1/2,A36,304.80,,PLATE
L,Holes,4,20.64,9.52,Slotted
*
D,C2,,C2,C2,1,w,16X89,A992,6686.55,,COLUMN
L,Weld,1,1879.60,6.35,w10
L,Weld,2,304.80,4.76,w10
D,C2,,C2,BP2,1,PL,3/4X26,A36,660.40,,PLATE
L,Holes,4,26.99,0.00,Round
S,1,1
D,C2,,C2,p7,1,FL,3/8X3-1/2,A36,304.80,,PLATE
L,Holes,4,20.64,9.53,Slotted
```

This advanced option is user specific and the setting is saved in `options.bin` under the user folder, for example, in `C:\Users\\AppData\Local\Trimble\Tekla Structures\\UserSettings`. Restart Tekla Structures to activate the new value.

18.55 XS_REPORT_OUTPUT_DIRECTORY

Category

File locations

Points to the folder where Tekla Structures saves reports. If the full path appears in the report file name field, Tekla Structures ignores this setting. The default value is `.\Reports`.

18.56 XS_RESTORE_ENABLES

Category

This advanced option must be set in an initialization (.ini) file.

Set this advanced option to `TRUE` to be able to save and load check box values in dialog boxes. `FALSE` is the default value.

18.57 XS_RIBBON_CONFIGURATION_CARBON

This advanced option must be set in an initialization (.ini) file.

Use this advanced option to control which ribbon is shown for a specified role for those users who are using the Tekla Structures Carbon configuration. The role-specific initialization files (`role_<role>.ini`), for example, `role_Steel_Detailer.ini` or `role_Rebar_Detailer.ini` contain the advanced option.

The advanced option needs to point the configuration identifier of the ribbon file, either to the configuration identifier of the legacy on-premises license configuration, or to the configuration identifier of the Tekla Structures subscription configuration. It is not possible to make up new configuration identifiers.

Example:

For the users who select the **Precast Concrete Detailing** role, you could have the following settings in the `role_Precast_Detailer.ini` file:

```
set XS_RIBBON_CONFIGURATION_CARBON=albl_up_Carbon
set XS_RIBBON_CONFIGURATION_GRAPHITE=albl_up_PC_Detailing
set XS_RIBBON_CONFIGURATION_DIAMOND=albl_up_PC_Detailing
```

See also

[XS_RIBBON_CONFIGURATION_GRAPHITE](#) (page 386)

[XS_RIBBON_CONFIGURATION_DIAMOND](#) (page 385)

18.58 XS_RIBBON_CONFIGURATION_DIAMOND

This advanced option must be set in an initialization (.ini) file.

Use this advanced option to control which ribbon is shown for a specified role for those users who are using the Tekla Structures Diamond configuration. The

role-specific initialization files (`role_<role>.ini`), for example, `role_Steel_Detailer.ini` or `role_Rebar_Detailer.ini` contain the advanced option.

The advanced option needs to point the configuration identifier of the ribbon file, either to the configuration identifier of the legacy on-premises license configuration, or to the configuration identifier of the Tekla Structures subscription configuration. It is not possible to make up new configuration identifiers.

Example:

For the users who select the **Precast Concrete Detailing** role, you could have the following settings in the `role_Precast_Detailer.ini` file:

```
set XS_RIBBON_CONFIGURATION_CARBON=albl_up_Carbon
set XS_RIBBON_CONFIGURATION_GRAPHITE=albl_up_PC_Detailing
set XS_RIBBON_CONFIGURATION_DIAMOND=albl_up_PC_Detailing
```

See also

[XS_RIBBON_CONFIGURATION_CARBON \(page 385\)](#)

[XS_RIBBON_CONFIGURATION_GRAPHITE \(page 386\)](#)

18.59 XS_RIBBON_CONFIGURATION_GRAPHITE

This advanced option must be set in an initialization (.ini) file.

Use this advanced option to control which ribbon is shown for a specified role for those users who are using the Tekla Structures Graphite configuration. The role-specific initialization files (`role_<role>.ini`), for example, `role_Steel_Detailer.ini` or `role_Rebar_Detailer.ini` contain the advanced option.

The advanced option needs to point the configuration identifier of the ribbon file, either to the configuration identifier of the legacy on-premises license configuration, or to the configuration identifier of the Tekla Structures subscription configuration. It is not possible to make up new configuration identifiers.

Example:

For the users who select the **Precast Concrete Detailing** role, you could have the following settings in the `role_Precast_Detailer.ini` file:

```
set XS_RIBBON_CONFIGURATION_CARBON=albl_up_Carbon
set XS_RIBBON_CONFIGURATION_GRAPHITE=albl_up_PC_Detailing
set XS_RIBBON_CONFIGURATION_DIAMOND=albl_up_PC_Detailing
```

See also

[XS_RIBBON_CONFIGURATION_CARBON](#) (page 385)

[XS_RIBBON_CONFIGURATION_DIAMOND](#) (page 385)

18.60 XS_ROTATE_CUT_VIEWS

Category

Drawing View

Use to specify the rotation of section views.

`BY_SYMBOL_MAIN_VIEW` (default) uses the orientation of the view that contains the section symbol. This only applies to section views that Tekla Structures creates automatically. Manually-created views have the same rotation as the view they are created from.

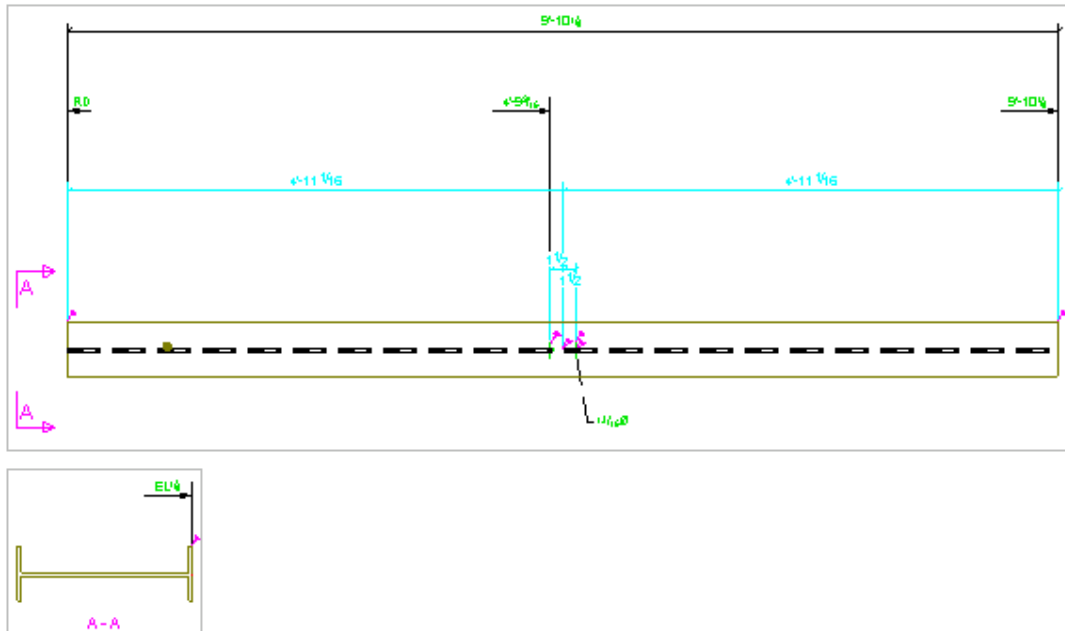

`BY_MAIN_VIEW` uses the same orientation as the main view.

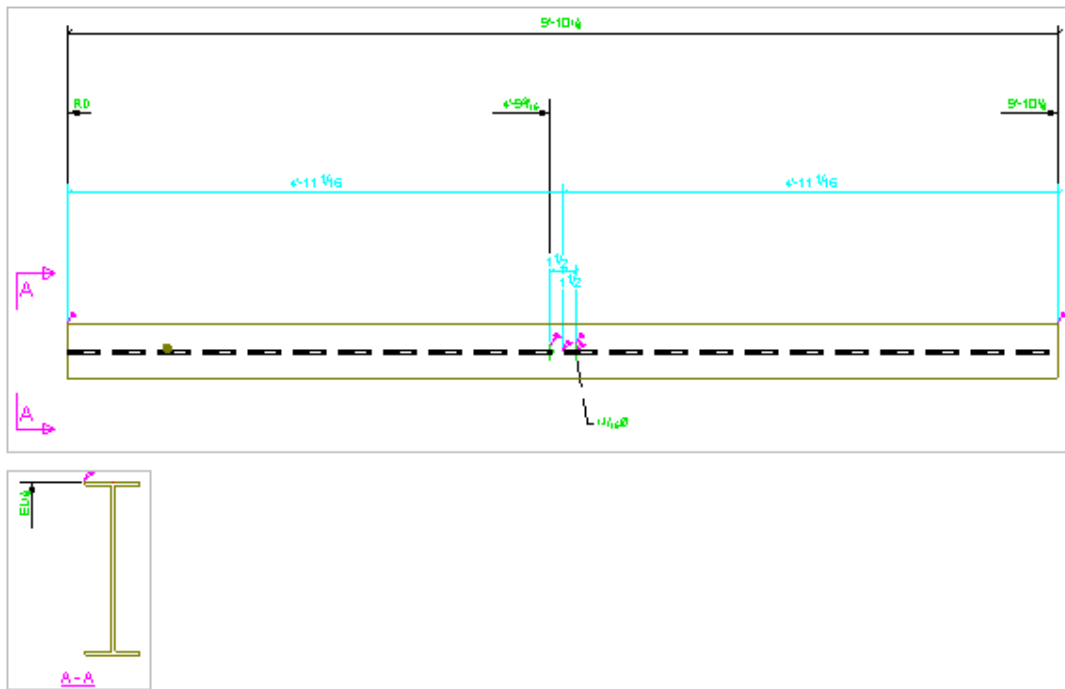

This advanced option is model specific and the setting is saved in the options database.

18.61 XS_RUN_AT_STARTUP

Category: File locations

Tekla Structures will automatically launch any executable (.exe) files that are located in the folders defined for this advanced option. You can enter several folders separated by a semicolon (;). By default, this advanced option is set as follows:

```
..\<version>\bin\applications\Tekla\ApplicationStartup;..\<version>\environments\common\extensions\ApplicationStartup\
```

This advanced option is user specific and the setting is saved in `options.bin` under the user folder, for example, in `C:\Users\<user>\AppData\Local\Trimble\Tekla Structures\<version>\UserSettings`. Restart Tekla Structures to activate the new value.

18.62 XS_RUNPATH

Category

This advanced option must be set in an initialization (.ini) file.

This advanced option is system specific and is read from `teklastructures.ini`. Generally, there is no need to modify system-specific settings. Do not modify them if you are not an administrator.

This advanced option points to the folder where Tekla Structures searches for models by default. When you open the **New** dialog box, the default model folder is displayed in the **Save in** list.

NOTE This advanced option does not affect the **Open** dialog box.

This advanced option is model specific and the setting is saved in the options database.

Example

```
set XS_RUNPATH=C:\TeklaStructuresModels\
```

18.63 XSR_USE_NO_FEET_SEPARATOR

Category

Templates and Symbols

Set this advanced option to `TRUE` to use a space instead of the feet separator in drawing tables and reports, for example, 2 4"1/4. To use the feet separator, use the value `FALSE`. The default value is `FALSE`.

You also need to set `XSR_USE_NO_FEET_SYMBOL`.

This advanced option is model specific and the setting is saved in the options database.

See also

[XSR_USE_NO_FEET_SYMBOL \(page 389\)](#)

18.64 XSR_USE_NO_FEET_SYMBOL

Category

Templates and Symbols

Set this advanced option to `TRUE` to omit the feet symbol in drawing tables and reports, for example, 2-4"1/4. If you do not want to omit the feet symbol, use the value `FALSE`. The default value is `FALSE`.

This advanced option is model specific and the setting is saved in the options database.

18.65 XSR_USE_NO_INCH_SYMBOL

Category

Templates and Symbols

Set this advanced option to `TRUE` to omit the inch symbol in drawing tables and reports, for example, 2-4 ¼. If you do not want to omit the inch symbol, use the value `FALSE`. The default value is `FALSE`.

You also need to set `XSR_USE_NO_FEET_SYMBOL` and `XSR_USE_NO_FEET_SEPARATOR`.

This advanced option is model specific and the setting is saved in the options database.

See also

[XSR_USE_NO_FEET_SEPARATOR \(page 389\)](#)

[XSR_USE_NO_FEET_SYMBOL \(page 389\)](#)

18.66 XSR_USE_ZERO_FEET_VALUE

Category

Templates and Symbols

Set this advanced option to `TRUE` to force Tekla Structures to show zero feet for values less one foot, for example, 0'-6"3/4. If you do not want to show zero feet values, use the value `FALSE`. The default value is `FALSE`.

NOTE Setting this advanced option affects also the following:

- Length values in part and bolt marks
- Length values in templates (template attribute `LENGTH`)

This advanced option is model specific and the setting is saved in the options database.

See also

[XSR_BOLT_LENGTH_USE_ONLY_INCHES \(page 351\)](#)

18.67 XSR_USE_ZERO_INCH_FOR_FRACTIONS

Category

Templates and Symbols

Set this advanced option to `TRUE` to show zero inches for values only containing fractions, for example, 2'-3/4 or 0'1/4. If you do not want to do this, use the value `FALSE`. The default value is `FALSE`.

This advanced option is model specific and the setting is saved in the options database.

18.68 XSR_USE_ZERO_INCH_VALUE

Category

Templates and Symbols

Set this advanced option to `TRUE` to show zero inches for values only containing feet and fractions, for example, 2'-0"3/4 or 1/4. If you do not want to do this, use the value `FALSE`. The default value is `FALSE`.

This advanced option is model specific and the setting is saved in the options database.

19 Advanced options - S

19.1 XS_SAVE_WITH_COMMENT

Category

Multi-user

Set this advanced option to `TRUE` (default) to enable the saving of model revision comments in multi-user models and models shared with Tekla Model Sharing.

19.2 XS_SCALE_COPIED_OR_MOVED_OBJECTS_IN_DRAWINGS

Category

Drawing Properties

Use to define the scaling of objects that are copied or moved between drawing views that have different scales.

- To scale the objects according to the view scales, set the advanced option to `TRUE`.
- To keep the object sizes constant, set the advanced option to `FALSE` (default).

This advanced option is model specific and the setting is saved in the options database.

19.3 XS_SCALE_MARKS_TO_FIT_LIMIT

Category

Marking: Parts

Tekla Structures fits part marks near the part they belong to by scaling the text height. Set the minimum scale with this advanced option.

The default value is 1.0. This means that if you do not set the advanced option, Tekla Structures does not scale marks. Tekla Structures scales the text height in steps so that first it tries the scale of 0.9. If the mark does not fit, Tekla Structures scales the mark by 0.8, and so on.

Note that part mark's leader line type has to be either **Try along part** or **Always along part**.

This advanced option is model specific and the setting is saved in the options database.

Example

```
XS_SCALE_MARKS_TO_FIT_LIMIT=0.5
```

19.4 XS_SCREW_DIAMOND_WITHOUT_PHI

Category

Marking: Bolts

Set this advanced option to TRUE to prevent Tekla Structures from placing a phi symbol outside the frame of bolt marks (diamond type only). The default value is FALSE.

This advanced option is model specific and the setting is saved in the options database.

19.5 XS_SDNF_CONVERT_PL_PROFILE_TO_PLATE

Category

Export

Set this advanced option to TRUE to have SDNF exports convert plate profiles (PL) to contour plates. Works with SDNF versions 2.0 and 3.0. If you do not want to use this setting, Set it to FALSE. The default value is TRUE.

This advanced option is model specific and the setting is saved in the options database.

19.6 XS_SDNF_EXPORT_INCLUDE_GLOBAL_ID

Category

Export

Set this advanced option to `TRUE` to revert to the FrameWorksPlus ID number in SDNF exports. The default value is `FALSE`.

This advanced option only affects version 2.0 SDNF export, but not version 3.0 export.

This advanced option is model specific and the setting is saved in the options database.

See also

[XS_SDNF_IMPORT_STORE_MEMBER_NUMBER \(page 394\)](#)

19.7 XS_SDNF_IMPORT_MIRROR_SWAP_OFFSETS

Category

Import

Set this advanced option to `TRUE` to swap the end point offsets and start point offsets when an imported part is mirrored already in the SDNF software. If you set this advanced option to `FALSE`, the end point and start point offsets are not swapped. The default value is `TRUE`.

This advanced option is user specific and the setting is saved in `options.bin` under the user folder, for example, in `C:\Users\<user>\AppData\Local\Trimble\Tekla Structures\<version>\UserSettings`. Restart Tekla Structures to activate the new value.

19.8 XS_SDNF_IMPORT_STORE_MEMBER_NUMBER

Category

Import

Set this advanced option to `TRUE` to have Tekla Structures store the FrameWorksPlus ID number in SDNF imports. Tekla Structures stores the ID number in the user-defined attribute `SDNF_MEMBER_NUMBER`. If you do not want to do this, set the option to `FALSE`. The default value is `TRUE`.

This advanced option is model specific and the setting is saved in the options database.

For information on exporting the ID number, click the links below.

See also

[XS_SDNF_EXPORT_INCLUDE_GLOBAL_ID \(page 394\)](#)

[XS_PML_EXPORT_INCLUDE_GLOBAL_ID \(page 333\)](#)

19.9 XS_SECONDARY_PART_HARDSTAMP

Category

CNC















Set to `TRUE` to include hard stamps for main parts and any kind of secondary parts in DSTV files. Set to `FALSE` to create hard stamps only for main parts. The default value is `FALSE`.

This advanced option is model specific and the setting is saved in the options database.

19.10 XS_SECTION_LINE_COLOR

Category: Hatching

Use to add extra lines in different colors around automatic hatching in section views. Enter the numeric value of the color. See below for the colors and their numeric values.

| | |
|---|-------|
|  | = 152 |
|  | = 153 |
|  | = 160 |
|  | = 161 |
|  | = 162 |
|  | = 163 |
|  | = 164 |
|  | = 165 |
|  | = 154 |
|  | = 155 |
|  | = 156 |
|  | = 157 |
|  | = 158 |
|  | = 159 |
|  | = 130 |
|  | = 131 |
|  | = 132 |
|  | = 133 |

In the image above, the advanced option has been set to 0:



In the next example, the value 160 is used:

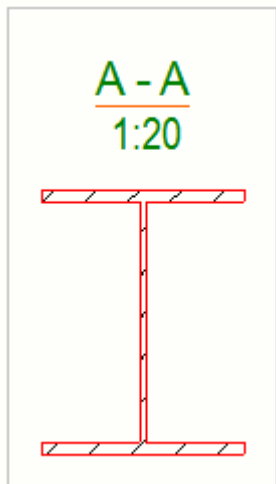

This advanced option is model specific and the setting is saved in the options database.

NOTE To show lines around hatching, and to be able to add extra lines in different colors, you may need to set advanced option `XS_DRAW_ALL_SECTION_EDGES_IN_DRAWINGS` to `TRUE` in the initialization files.

See also

[XS_DRAW_ALL_SECTION_EDGES_IN_DRAWINGS \(page 152\)](#)

19.11 XS_SECTION_SYMBOL_LEFT_ARROW_SYMBOL

Category: Drawing properties

Use to define the custom arrow symbol Tekla Structures uses in section symbols at the left end of sections. To use the custom arrow symbol, select **Custom** from the **Left symbol** list in the **Section symbol properties** dialog box.

By default, Tekla Structures uses the symbol no 1  in the `sections.sym` file (located usually in the folder `\environments\common\symbols\`). To use another symbol, enter the symbol file name first, then the @ sign and then the number of the symbol, for example `sections@1`.

Here's the symbol 0 selected in Symbol Editor:

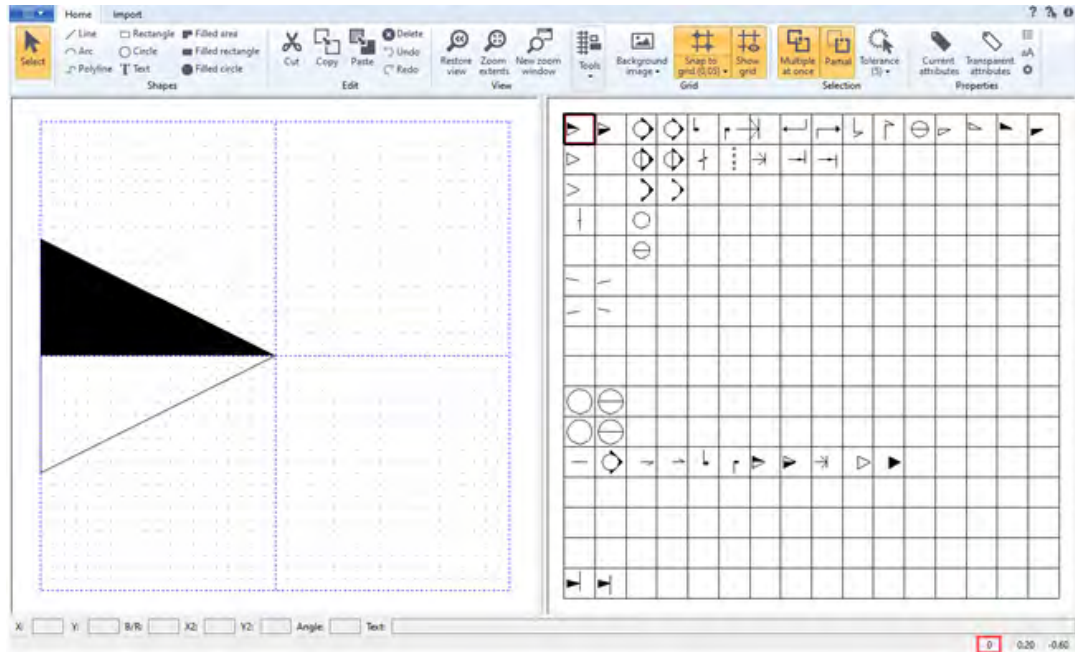

To open Symbol Editor, click **File** --> **Editors** --> **Symbol editor**. There you can open different symbol files and check the included symbols and their numbers.

This advanced option is model specific and the setting is saved in the options database.

See also

[XS_SECTION_SYMBOL_RIGHT_ARROW_SYMBOL](#) (page 399)

[Creating custom section arrows in a special format](#)

19.12 XS_SECTION_SYMBOL_REFERENCE

Category: Drawing properties

You can move drawing views from one drawing to another. This advanced option sets the reference text for section symbols for section views moved to another drawing. You can enter free text, user-defined attributes (%UDA_NAME%, %USERDEFINED.UDA_NAME%), or template attributes (%ATTRIBUTE_NAME%).

If you enter user-defined attributes or template attributes, use single % characters around them in the **Advanced options** dialog box.

%DRAWING_TITLE% is the default value, and %TITLE% gives the same result. If you use these attributes, the symbol gets the drawing name entered in the **Name** field in the drawing properties dialog box. If you enter %TITLE1%, %TITLE2%, or %TITLE3%, the symbol gets the text from the **Title 1 - Title 3**

fields in drawing properties. You can also use the format %DR_TITLE1%, %DR_TITLE2%, and %DR_TITLE3% to do the same.

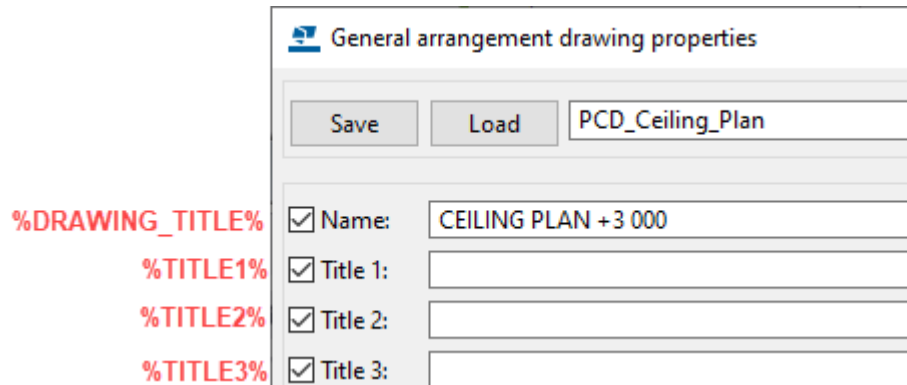

In the following example, the %DRAWING_TITLE% is used:

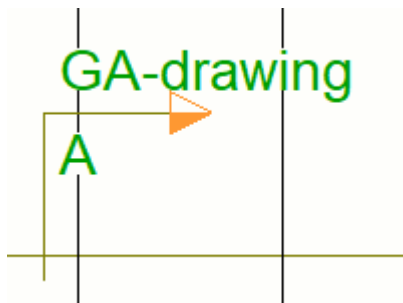

For more information about moving views to another drawing, see Copy, link, or move drawing views.

This advanced option is model specific and the setting is saved in the options database.

19.13 XS_SECTION_SYMBOL_RIGHT_ARROW_SYMBOL

Category: Drawing properties

Use to define the custom arrow symbol Tekla Structures uses in section symbols at the right end of sections. To use the custom arrow symbol, select **Custom** from the **Right symbol** list in the **Section symbol properties** dialog box.

By default Tekla Structures uses the symbol no 0  in the `sections.sym` file (located usually in the folder `..\environments\common\symbols\`). To use another symbol, enter the symbol file name first, then the @ sign and then the number of the symbol, for example `sections@0`.

Here's the symbol selected in Symbol Editor:

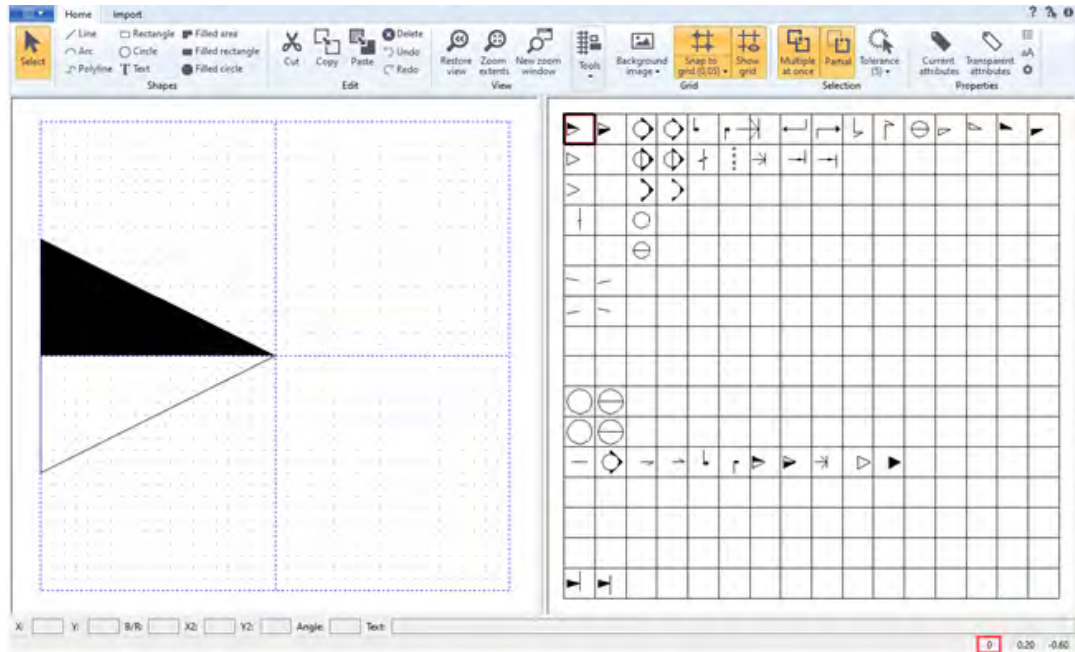

To open Symbol Editor, click **File** --> **Editors** --> **Symbol editor**. There you can open different symbol files and check the included symbols and their numbers.

This advanced option is model specific and the setting is saved in the options database.

See also

[XS_SECTION_SYMBOL_LEFT_ARROW_SYMBOL](#) (page 397)

[Creating custom section arrows in a special format](#)

19.14 XS_SECTION_VIEW_REFERENCE

Category: Drawing properties

You can move drawing views from one drawing to another. This advanced option sets the reference text for section view labels for sections moved to another drawing. You can enter free text, user-defined attributes (%UDA_NAME%, %USERDEFINED.UDA_NAME%), or template attributes (%ATTRIBUTE_NAME%).

If you enter user-defined attributes or template attributes, use single % characters around them in the **Advanced options** dialog box. The %DRAWING_TITLE% attribute is the default value, and the %TITLE% attribute gives the same result. If you use these attributes, the view label gets the drawing name entered in the **Name** field in the drawing properties dialog box. If you enter %TITLE1%, %TITLE2%, or %TITLE3%, the view label gets the text

from the **Title 1 - Title 3** fields in drawing properties. You can also use the format `%DR_TITLE1%`, `%DR_TITLE2%`, and `%DR_TITLE3%` to do the same.

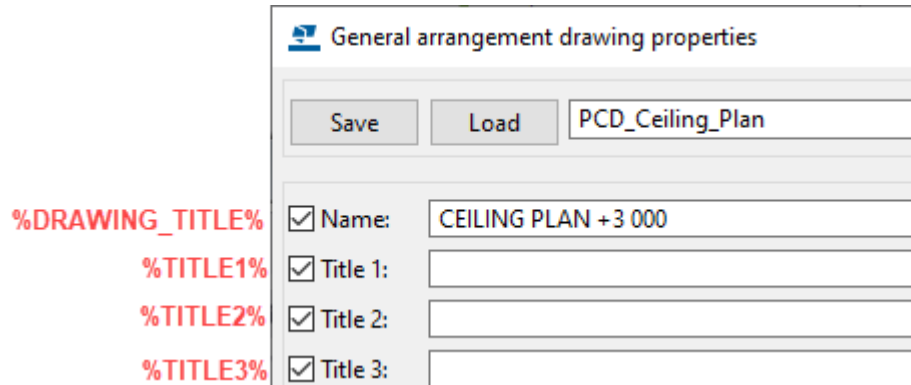

This advanced option is model specific and the setting is saved in the options database.

See also

[XS_SECTION_SYMBOL_REFERENCE](#) (page 398)

19.15 XS_SET_FIXEDMAINVIEW_UDA_TO_AFFECT_NUMBERING

Category: Numbering

To activate the **Show top-in-form face** for non-concrete material, use the advanced option `XS_SET_FIXEDMAINVIEW_UDA_TO_AFFECT_NUMBERING`. The allowed options are `STEEL`, `TIMBER` and `MISC`. You can also combine the options, use a comma (,) as a separator.

This advanced option affects numbering. If parts have different options selected for **Fixed drawing main view**, they get different assembly position numbers.

To show the top-in-form face in drawings and set which view is used in drawings as the main (front) view, go to the user-defined properties of a non-concrete part and select the **Fixed drawing main view** option that you want. The options are **Top**, **Back**, **Bottom**, **Start**, **End** and **Front**.

This advanced option is model specific and the setting is saved in the options database.

19.16 XS_SET_HATCH_ORIGIN_INTO_VIEW_ORIGIN

Category: Hatching

Hatches are drawn consistently between parts and set to origin, if you set the advanced option `XS_SET_HATCH_ORIGIN_INTO_VIEW_ORIGIN` to `TRUE` and the scaling and rotation of hatches to zero (0). The default value is `FALSE`.

For automatic hatches, the scale and rotation are set in the `.htc` file, for example, `CONCRETE, 0, hardware_LINES, , 120`, where the value 0 (or empty) sets auto scale and rotation to false.

For manual hatches, the scale and rotation are set on the **Fill** tab of parts properties or shape properties dialog boxes, where you need to set the **Scale** option to **Custom** and select the **Keep ratio of x and y** check box.

In the example below, the parts that belong to the same cast unit are hatched consistently.

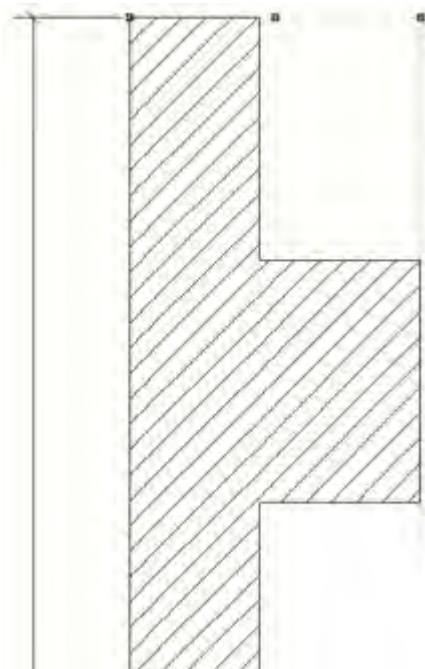

This advanced option is model specific and the setting is saved in the options database.

19.17 XS_SET_MAX_POINT_CLOUD_POINT_COUNT

Category: Model views

Use this advanced option to set the default maximum number of points in a point cloud in a view. The default value is 10 000 000 (10 million). This

advanced option does not affect how many points are imported, only how many points are shown.

If you discover speed issues, set the count smaller. When the count is smaller, the point cloud appears less dense. If you use a higher value, the dense point cloud may provide more surface kind of appearance due to the smaller point distance.

Changing this advanced option can also be done after attaching the point cloud. Let's say you have 10 000 000 points in the point cloud, and you set `XS_SET_MAX_POINT_CLOUD_POINT_CLOUD` to 1000, and attach the point cloud to the model. Then, 10 000 000 points are in the model, but as the advanced option is set to 1000, only 1000 of the points are shown, evenly distributed within the view. If you change the advanced option value to 1 000 000 after you have attached the point cloud, 1 000 000 points are shown, evenly distributed within the view. There is no need for reimport after changing the advanced option.

This advanced option is system specific and is read from environment files. Generally, there is no need to modify system-specific settings. Do not modify them if you are not an administrator.

Restart Tekla Structures after changing the value to activate the new setting.

19.18 XS_SHARING_INFO_URL

Category: Multi-user

Use this advanced option to set the Tekla Model Sharing management server address.

This advanced option is system-specific. Generally, there is no need to modify system-specific settings. Do not modify them if you are not an administrator.

19.19 XS_SHARING_JOIN_SHOW_AVAILABLE_VERSIONS

NOTE We recommend you to set this advanced option in **File menu --> Sharing --> Sharing settings**. Select the **Show available updates when joining the model** option.

Use this advanced option to show a list of all the available baselines and updates which to join in Tekla Model Sharing. The list is shown when a user joins a model.

If needed, the advanced option can be set in initialization files. Set `XS_SHARING_JOIN_SHOW_AVAILABLE_VERSIONS` to `TRUE` in initialization files to enable the list.

This advanced option is user-specific.

19.20 XS_SHARING_READIN_SHOW_AVAILABLE_VERSIONS

NOTE We recommend you to set this advanced option in **File menu --> Sharing --> Sharing settings**. Select the **Show available updates when reading in the changes** option.

Use this advanced option to show a list of available updates when a user reads in the model changes in Tekla Model Sharing.

If needed, the advanced option can be set in initialization files. Set `XS_SHARING_READIN_SHOW_AVAILABLE_VERSIONS` to `TRUE` in initialization files to enable the list.

This advanced option is user-specific.

19.21 XS_SHARING_READIN_SHOW_CHANGEMANAGER

NOTE We recommend you to set this advanced option in **File menu --> Sharing --> Sharing settings**. Select the **Show changes after read in** option.

Use this advanced option to show a list model changes at the bottom pane after you have read in the model changes in Tekla Model Sharing.

If needed, the advanced option can be set in initialization files. Set `XS_SHARING_READIN_SHOW_CHANGEMANAGER` to `TRUE` in initialization files.

This advanced option is user-specific.

19.22 XS_SHARING_READIN_SHOW_CHANGEMANAGER_CONFLICTSONLY

NOTE We recommend you to set this advanced option in **File menu --> Sharing --> Sharing settings**. Select the **Show changes after read in** and **Only when conflicts exist** options.

Use this advanced option to show a list model changes at the bottom pane after you have read in the model changes in Tekla Model Sharing and when there are conflicts.

If needed, the advanced option can be set in initialization files. Set `XS_SHARING_READIN_SHOW_CHANGEMANAGER` and `XS_SHARING_READIN_SHOW_CHANGEMANAGER_CONFLICTSONLY` to `TRUE` in initialization files.

This advanced option is user-specific.

19.23 XS_SHARING_TEMP

Category: Multi-user

Use this advanced option to define the temporary folder for Tekla Model Sharing packet management. The default is the Windows temporary folder.

Note that the folder path can be maximum 70 characters long.

This advanced option is user specific and the setting is saved in `options.bin` under the user folder, for example, in `C:\Users\\AppData\Local\Trimble\Tekla Structures\\UserSettings`. Restart Tekla Structures to activate the new value.

19.24 XS_SHOP_BOLT_MARK_STRING_FOR_SIZE

Category: Marking - bolts

Use to define the contents of the **Size** element in bolt marks (workshop). The default value is `%BOLT_NUMBER%*D%HOLE.DIAMETER% - M%DIAMETER%x %LENGTH%`.

This advanced option is only used when there is a bolt and the hole is a normal one.

You can use any combination of text and the following options as the value for this advanced option. You can use the options in any order, and make calculations.

- BOLT_NUMBER
- DIAMETER
- LENGTH
- HOLE.DIAMETER
- LONG_HOLE_X
- LONG_HOLE_Y
- LONGHOLE_MIN (the shorter of the slotted hole dimensions)
- LONGHOLE_MAX (the longer of the slotted hole dimensions)
- BOLT_STANDARD
- BOLT_MATERIAL
- BOLT_ASSEMBLY_TYPE
- BOLT_COUNTERSUNK
- BOLT_SHORT_NAME
- BOLT_FULL_NAME

Enclose each option in % characters.

Note that if you are defining this advanced option in an `.ini` file, use double percent signs around the options. For example, `%%BOLT_NUMBER%%*D%
%HOLE.DIAMETER%%`.

To use special characters, enter a backslash (\) followed by an ASCII number.

With length-type options, but not in calculations, you can specify the number of decimals. For example, `HOLE.DIAMETER.2` shows (tapped) hole diameters with two decimals.

This advanced option is model specific and the setting is saved in the options database.

19.25 XS_SHOP_BOLT_MARK_STRING_FOR_SIZE_IN_GA

Category: Marking - bolts

Use to define the contents of the size element in bolt marks for workshop bolts in general arrangement drawings.

This advanced option is only used when there is a bolt and the hole is a normal one.

You can use any combination of text and the following options as the value for this advanced option. You can use the options in any order, and make calculations.

- BOLT_NUMBER
- DIAMETER
- LENGTH
- HOLE.DIAMETER
- LONG_HOLE_X
- LONG_HOLE_Y
- LONGHOLE_MIN (the shorter of the slotted hole dimensions)
- LONGHOLE_MAX (the longer of the slotted hole dimensions)
- BOLT_STANDARD
- BOLT_MATERIAL
- BOLT_ASSEMBLY_TYPE
- BOLT_COUNTERSUNK
- BOLT_SHORT_NAME
- BOLT_FULL_NAME

Enclose each option in % characters.

Note that if you are defining this advanced option in an `.ini` file, use double percent signs around the options. For example, `%%BOLT_NUMBER%%*D%
%HOLE.DIAMETER%%`.

To use special characters, enter a backslash (\) followed by an ASCII number.

With length-type options, but not in calculations, you can specify the number of decimals. For example, `HOLE.DIAMETER.2` shows (tapped) hole diameters with two decimals.

This advanced option is model specific and the setting is saved in the options database.

See also

[XS_SHOP_HOLE_MARK_STRING_FOR_SIZE_IN_GA \(page 409\)](#)

[XS_SHOP_LONGHOLE_MARK_STRING_FOR_SIZE_IN_GA \(page 411\)](#)

19.26 XS_SHOP_HOLE_MARK_STRING_FOR_SIZE

Category: Marking - bolts

Use to define the contents of the **Size** element in hole marks (workshop). For example, to show bolt number and hole diameter, enter `%BOLT_NUMBER%*D%HOLE.DIAMETER%`.

This advanced option is only used when there is a hole, no bolt (and the hole is a normal one).

You can use any combination of text and the following options as the value for this advanced option. You can use the options in any order, and make calculations.

- BOLT_NUMBER
- DIAMETER
- LENGTH
- HOLE.DIAMETER
- LONG_HOLE_X
- LONG_HOLE_Y
- LONGHOLE_MIN (the shorter of the slotted hole dimensions)
- LONGHOLE_MAX (the longer of the slotted hole dimensions)
- BOLT_STANDARD
- BOLT_MATERIAL
- BOLT_ASSEMBLY_TYPE
- BOLT_COUNTERSUNK
- BOLT_SHORT_NAME
- BOLT_FULL_NAME

Enclose each option in % characters.

Note that if you are defining this advanced option in an `.ini` file, use double percent signs around the options. For example, `%%BOLT_NUMBER%%*D%HOLE.DIAMETER%%`.

To use special characters, enter a backslash (\) followed by an ASCII number.

With length-type options, but not in calculations, you can specify the number of decimals. For example, `HOLE.DIAMETER.2` shows (tapped) hole diameters with two decimals.

This advanced option is model specific and the setting is saved in the options database.

19.27 XS_SHOP_HOLE_MARK_STRING_FOR_SIZE_IN_GA

Category: Marking - bolts

Use to define the contents of the size element in hole marks for workshop bolts in general arrangement drawings.

This advanced option is only used when there is a hole, no bolt (and the hole is a normal one).

You can use any combination of text and the following options as the value for this advanced option. You can use the options in any order, and make calculations.

- BOLT_NUMBER
- DIAMETER
- LENGTH
- HOLE.DIAMETER
- LONG_HOLE_X
- LONG_HOLE_Y
- LONGHOLE_MIN (the shorter of the slotted hole dimensions)
- LONGHOLE_MAX (the longer of the slotted hole dimensions)
- BOLT_STANDARD
- BOLT_MATERIAL
- BOLT_ASSEMBLY_TYPE
- BOLT_COUNTERSUNK
- BOLT_SHORT_NAME
- BOLT_FULL_NAME

Enclose each option in % characters.

Note that if you are defining this advanced option in an `.ini` file, use double percent signs around the options. For example, `%%BOLT_NUMBER%%*D%
%HOLE.DIAMETER%%.`

To use special characters, enter a backslash (\) followed by an ASCII number.

With length-type options, but not in calculations, you can specify the number of decimals. For example, `HOLE.DIAMETER.2` shows (tapped) hole diameters with two decimals.

This advanced option is model specific and the setting is saved in the options database.

See also

[XS_SHOP_BOLT_MARK_STRING_FOR_SIZE_IN_GA](#) (page 406)

[XS_SHOP_LONGHOLE_MARK_STRING_FOR_SIZE_IN_GA](#) (page 411)

19.28 XS_SHOP_LONGHOLE_MARK_STRING_FOR_SIZE

Category: Marking - bolts

Use to define the contents of the **Size** element in slotted hole marks (workshop). The default value is `%BOLT_NUMBER%*D%HOLE.DIAMETER% (%HOLE.DIAMETER+LONGHOLE_MIN%x%HOLE.DIAMETER+LONGHOLE_MAX%) - M%DIAMETER%x%LENGTH%`.

This advanced option is only used when there is a slotted hole.

You can use any combination of text and the following options as the value for this advanced option. You can use the options in any order, and make calculations.

- BOLT_NUMBER
- DIAMETER
- LENGTH
- HOLE.DIAMETER
- LONG_HOLE_X
- LONG_HOLE_Y
- LONGHOLE_MIN (the shorter of the slotted hole dimensions)
- LONGHOLE_MAX (the longer of the slotted hole dimensions)
- BOLT_STANDARD
- BOLT_MATERIAL
- BOLT_ASSEMBLY_TYPE
- BOLT_COUNTERSUNK
- BOLT_SHORT_NAME
- BOLT_FULL_NAME

Enclose each option in % characters.

Note that if you are defining this advanced option in an `.ini` file, use double percent signs around the options. For example, `%%BOLT_NUMBER%%*D%
%HOLE.DIAMETER%%`.

To use special characters, enter a backslash (\) followed by an ASCII number.

With length-type options, but not in calculations, you can specify the number of decimals. For example, `HOLE.DIAMETER.2` shows (tapped) hole diameters with two decimals.

This advanced option is model specific and the setting is saved in the options database.

19.29 XS_SHOP_LONGHOLE_MARK_STRING_FOR_SIZE_IN_GA

Category: Marking - bolts

Use to define the contents of the size element in slotted hole marks for workshop bolts in general arrangement drawings.

This advanced option is only used when there is a slotted hole.

You can use any combination of text and the following options as the value for this advanced option. You can use the options in any order, and make calculations.

- BOLT_NUMBER
- DIAMETER
- LENGTH
- HOLE.DIAMETER
- LONG_HOLE_X
- LONG_HOLE_Y
- LONGHOLE_MIN (the shorter of the slotted hole dimensions)
- LONGHOLE_MAX (the longer of the slotted hole dimensions)
- BOLT_STANDARD
- BOLT_MATERIAL
- BOLT_ASSEMBLY_TYPE
- BOLT_COUNTERSUNK
- BOLT_SHORT_NAME
- BOLT_FULL_NAME

Enclose each option in % characters.

Note that if you are defining this advanced option in an `.ini` file, use double percent signs around the options. For example, `%%BOLT_NUMBER%%*D%
%HOLE.DIAMETER%%`.

To use special characters, enter a backslash (\) followed by an ASCII number.

With length-type options, but not in calculations, you can specify the number of decimals. For example, `HOLE.DIAMETER.2` shows (tapped) hole diameters with two decimals.

This advanced option is model specific and the setting is saved in the options database.

19.30 XS_SHOP_OVERSIZEDHOLE_MARK_STRING_FOR_SIZE

Category: Marking - bolts

Use to define the contents of the **Size** element in marks for oversized bolt holes (workshop). The default value is `%BOLT_NUMBER%*D%HOLE.DIAMETER%`.

This advanced option is only used when there is an oversized hole.

You can use any combination of text and the following options as the value for this advanced option. You can use the options in any order, and make calculations.

- BOLT_NUMBER
- DIAMETER
- LENGTH
- HOLE.DIAMETER
- LONG_HOLE_X
- LONG_HOLE_Y
- LONGHOLE_MIN (the shorter of the slotted hole dimensions)
- LONGHOLE_MAX (the longer of the slotted hole dimensions)
- BOLT_STANDARD
- BOLT_MATERIAL
- BOLT_ASSEMBLY_TYPE
- BOLT_COUNTERSUNK
- BOLT_SHORT_NAME
- BOLT_FULL_NAME

Enclose each option in % characters.

Note that if you are defining this advanced option in an `.ini` file, use double percent signs around the options. For example, `%%BOLT_NUMBER%%*D%%
%HOLE.DIAMETER%%`.

To use special characters, enter a backslash (\) followed by an ASCII number.

With length-type options, but not in calculations, you can specify the number of decimals. For example, `HOLE.DIAMETER.2` shows (tapped) hole diameters with two decimals.

This advanced option is model specific and the setting is saved in the options database.

See also

[XS_SITE_OVERSIZEDHOLE_MARK_STRING_FOR_SIZE \(page 438\)](#)

[XS_SHOP_OVERSIZEDHOLE_MARK_STRING_FOR_SIZE_IN_GA \(page 413\)](#)

19.31 XS_SHOP_OVERSIZEDHOLE_MARK_STRING_FOR_SIZE_IN_GA

Category: Marking - bolts

Use to define the contents of the **Size** element in oversized hole marks for workshop bolts in general arrangement drawings.

This advanced option is only used when there is an oversized hole.

You can use any combination of text and the following options as the value for this advanced option. You can use the options in any order, and make calculations.

- BOLT_NUMBER
- DIAMETER
- LENGTH
- HOLE.DIAMETER
- LONG_HOLE_X
- LONG_HOLE_Y
- LONGHOLE_MIN (the shorter of the slotted hole dimensions)
- LONGHOLE_MAX (the longer of the slotted hole dimensions)
- BOLT_STANDARD
- BOLT_MATERIAL
- BOLT_ASSEMBLY_TYPE
- BOLT_COUNTERSUNK

- BOLT_SHORT_NAME
- BOLT_FULL_NAME

Enclose each option in % characters.

Note that if you are defining this advanced option in an `.ini` file, use double percent signs around the options. For example, `%%BOLT_NUMBER%%*D%
%HOLE.DIAMETER%%`.

To use special characters, enter a backslash (\) followed by an ASCII number.

With length-type options, but not in calculations, you can specify the number of decimals. For example, `HOLE.DIAMETER.2` shows (tapped) hole diameters with two decimals.

This advanced option is model specific and the setting is saved in the options database.

See also

[XS_SITE_OVERSIZEDHOLE_MARK_STRING_FOR_SIZE_IN_GA \(page 439\)](#)

[XS_SHOP_OVERSIZEDHOLE_MARK_STRING_FOR_SIZE \(page 412\)](#)

19.32 XS_SHOP_TAPPEDHOLE_MARK_STRING_FOR_SIZE

Category: Marking - bolts

Use to define the contents of the **Size** element in marks for tapped bolt holes (workshop). The default value is `%BOLT_NUMBER%*\216%HOLE.DIAMETER.1%
TAP M%BOLT_DIAMETER%`.

This advanced option is only used when there is a tapped hole.

You can use any combination of text and the following options as the value for this advanced option. You can use the options in any order, and make calculations.

- BOLT_NUMBER
- DIAMETER
- LENGTH
- HOLE.DIAMETER
- LONG_HOLE_X
- LONG_HOLE_Y
- LONGHOLE_MIN (the shorter of the slotted hole dimensions)
- LONGHOLE_MAX (the longer of the slotted hole dimensions)
- BOLT_STANDARD

- BOLT_MATERIAL
- BOLT_ASSEMBLY_TYPE
- BOLT_COUNTERSUNK
- BOLT_SHORT_NAME
- BOLT_FULL_NAME

Enclose each option in % characters.

Note that if you are defining this advanced option in an `.ini` file, use double percent signs around the options. For example, `%%BOLT_NUMBER%%*D%%
%HOLE.DIAMETER%%`.

To use special characters, enter a backslash (\) followed by an ASCII number.

With length-type options, but not in calculations, you can specify the number of decimals. For example, `HOLE.DIAMETER.2` shows (tapped) hole diameters with two decimals.

This advanced option is model specific and the setting is saved in the options database.

See also

[XS_SITE_TAPPEDHOLE_MARK_STRING_FOR_SIZE \(page 440\)](#)

[XS_SHOP_TAPPEDHOLE_MARK_STRING_FOR_SIZE_IN_GA \(page 415\)](#)

19.33 XS_SHOP_TAPPEDHOLE_MARK_STRING_FOR_SIZE_IN_GA

Category: Marking - bolts

Use to define the contents of the **Size** element in tapped hole marks for workshop bolts in general arrangement drawings.

This advanced option is only used when there is a tapped hole.

You can use any combination of text and the following options as the value for this advanced option. You can use the options in any order, and make calculations.

- BOLT_NUMBER
- DIAMETER
- LENGTH
- HOLE.DIAMETER
- LONG_HOLE_X
- LONG_HOLE_Y

- LONGHOLE_MIN (the shorter of the slotted hole dimensions)
- LONGHOLE_MAX (the longer of the slotted hole dimensions)
- BOLT_STANDARD
- BOLT_MATERIAL
- BOLT_ASSEMBLY_TYPE
- BOLT_COUNTERSUNK
- BOLT_SHORT_NAME
- BOLT_FULL_NAME

Enclose each option in % characters.

Note that if you are defining this advanced option in an `.ini` file, use double percent signs around the options. For example, `%%BOLT_NUMBER%%*D%%
%HOLE.DIAMETER%%`.

To use special characters, enter a backslash (\) followed by an ASCII number.

With length-type options, but not in calculations, you can specify the number of decimals. For example, `HOLE.DIAMETER.2` shows (tapped) hole diameters with two decimals.

This advanced option is model specific and the setting is saved in the options database.

See also

[XS_SITE_TAPPEDHOLE_MARK_STRING_FOR_SIZE_IN_GA \(page 441\)](#)

[XS_SHOP_TAPPEDHOLE_MARK_STRING_FOR_SIZE \(page 414\)](#)

19.34 XS_SHORTENING_SYMBOL_COLOR

Category: Drawing properties

Use this advanced option to set the color of the view shortening symbol. Enter an integer value. Default is the same as the part color. See below for integers for different colors.







| | |
|---|-----|
|  | 153 |
|  | 160 |
|  | 161 |
|  | 162 |
|  | 163 |
|  | 164 |
|  | 165 |
|  | 154 |
|  | 155 |
|  | 156 |
|  | 157 |
|  | 158 |
|  | 159 |

This advanced option is model specific and the setting is saved in the options database.

19.35 XS_SHORTENING_SYMBOL_LINE_TYPE

Category: Drawing properties

Use this advanced option to set the line type of the view shortening symbol. Enter an integer value. Default is a solid line. See below for integer values for different line types.

| | |
|---|---|
|  | 1 |
|  | 2 |
|  | 3 |
|  | 4 |
|  | 5 |
|  | 6 |
|  | 7 |

This advanced option is model specific and the setting is saved in the options database.

19.36 XS_SHORTENING_SYMBOL_WITH_ZIGZAG

Category: Drawing properties

Use this advanced option to set the shortening symbol line shape. If you do not want to use zigzag, set this advanced option to `FALSE`. `TRUE` is the default.

This advanced option is model specific and the setting is saved in the options database.

TIP You can control the appearance of the view shortening symbol with the advanced options `XS_SHORTENING_SYMBOL_COLOR` (page 416) and `XS_SHORTENING_SYMBOL_LINE_TYPE` (page 417).

To use a view shortening symbol instead of the empty area, set the advanced options `XS_DRAW_VERTICAL_VIEW_SHORTENING_SYMBOLS_TO_PARTS` (page 172) and `XS_DRAW_HORIZONTAL_VIEW_SHORTENING_SYMBOLS_TO_PARTS` (page 166) to `TRUE`.

19.37 XS_SHOW_HARDWARE_DASHED_LINE_IN_PIXEL_SCALE

Category: Drawing properties

Set `XS_SHOW_HARDWARE_DASHED_LINE_IN_PIXEL_SCALE` to `FALSE` to activate the functionality, where dashed hardware line scale is the same as in printed and exported drawings, and the dashed hardware lines work in the same way as the custom lines.

Dashed hardware line types are scaled by pixels by default (`TRUE`), which means that they look the same in all zoom levels.

Dashed hardware lines are the first couple of lines in the line list:

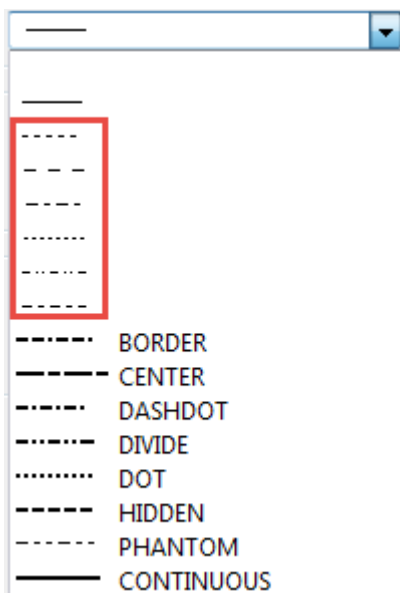

This advanced option is user specific and the setting is saved in `options.bin` under the user folder, for example, in `C:\Users\\AppData\Local\Trimble\Tekla Structures\\UserSettings`. Restart Tekla Structures to activate the new value.

19.38 XSR_SHOW_INCH_MARK_IN_PROFILE_NAMES

Category

Templates and Symbols

Use to show or hide the inch symbol in the profile name in reports and templates. When you set the advanced option to `TRUE`, the profile appears like this: PL2 1/2"X20". When you set the advanced option to `FALSE`, the profile appears like this: PL2 1/2X20. The default value is `TRUE`.

This advanced option is model specific and the setting is saved in the options database.

See also

[XS_PROFILE_DISPLAY_INCH_MARK_AFTER_FRACTIONS_IN_REPORTS](#) (page 349)

19.39 XS_SHOW_NOTIFICATION_REPORT

Category: Modeling Properties

Set to `TRUE` to run and display a notification report from the whole model when you open a model.

You can use the notification report to, for example:

- List assignments on all objects (drawings, parts and assemblies).
- Report how many assemblies there are in the model, how many assembly drawings have been created, and how many of them have been approved and how many have been issued for production.

The report template used is named `notification_report`, and you can edit it in Template Editor. Notification report reports anything you want, not just assignments. You need to edit the report template to report the things you need. For example, some environments do not have all attributes available, like `ASSIGNED_TO` or `ASSIGNED_BY`, for parts and assemblies.

If you do not want to display the notification report upon opening a model, set the advanced option to `FALSE`, which is the default value.

This advanced option is model specific and the setting is saved in the options database.

Example of a list of drawing assignments:

PROJECT NEWS!!!!

This is an automatic newflash for project participants

This message is shown when anyone opens the model or runs "notification_report" report template

NOTIFICATION OF ASSIGNMENTS CONTRACT NO: 1 Page: 1
Objects assigned to user1 Date: 07.11.2016

| Object | Name | Assigned to | Assigned by | Comment |
|-----------|--------------|-------------|-------------|---------|
| A Drawing | [A.1] PLATE | user1 | user2 | OK |
| A Drawing | [C.2] COLUMN | user1 | user2 | OK |

0 assemblies, 0 parts and 2 drawings have been assigned to

19.40 XS_SHOW_PERFORM_NUMBERING_MESSAGE

Category

Numbering

Use to show or hide the **Perform numbering** button in the warning message Tekla Structures displays if you try to create a drawing without numbering or when numbering is not up to date.

- By default, this advanced option is set to `TRUE` and the numbering button is shown.
- To hide the button, set this advanced option to `FALSE`.

Consider hiding the numbering button in the multi-user mode, because unnecessary or unplanned numbering may take a while in large models or break project numbering. This can occur if **Synchronize with master model (save-numbering-save)** check box is not selected in the **Numbering setup** dialog box.

This advanced option is model specific and the setting is saved in the options database.

19.41 XS_SHOW_PROGRESS_BAR_FOR_PROJECT_STATUS_VISUALIZATION

Category

Model View

Use for defining whether the progress bar for project status visualization is displayed or not.

To display the progress bar, set this advanced option to `TRUE` (default). If you do not want to display the progress bar, set this advanced option to `FALSE`.

This advanced option is user specific and the setting is saved in `options.bin` under the user folder, for example, in `C:\Users\\AppData\Local\Trimble\Tekla Structures\\UserSettings`. Restart Tekla Structures to activate the new value.

19.42 XS_SHOW_REVISION_MARK_ON_DRAWING_LIST

Category: Drawing properties

Set this advanced option to `TRUE` to have Tekla Structures include the **Revision mark** in **Document manager** instead of the **Revision number**. The default value is `FALSE`. This means that the revision number is shown.

This advanced option is user specific and the setting is saved in `options.bin` under the user folder, for example, in `C:\Users\\AppData\Local\Trimble\Tekla Structures\\UserSettings`. Restart Tekla Structures to activate the new value.

19.43 XS_SHOW_SHADOW_FOR_ORTHO_IN_DX

Category: Model views

Use this advanced option to control whether shadows are shown in the DirectX rendered model views when the orthogonal projection is on. Shadows are more noticeable in the perspective projection than in the orthogonal projection.

By default, this advanced option is set to `FALSE`.

If you change the value, you need to reopen the view to activate the new value.

19.44 XS_SHOW_SHADOW_FOR_PERSPECTIVE_IN_DX

Category: Model views

Use this advanced option to control whether shadows are shown in the DirectX rendered model views when the perspective projection is on. Shadows are

more noticeable in the perspective projection than in the orthogonal projection.

By default, this advanced option is set to `TRUE`.

If you change the value, you need to reopen the view to activate the new value.

19.45 XS_SHOW_SITE_STUDS_IN_ASSEMBLY_DRAWINGS

Category

Drawing Properties

Set this advanced option to `TRUE` (default) to show site studs in assembly drawings. If you set it to `FALSE`, the site studs are not shown.

This advanced option is model specific and the setting is saved in the options database.

19.46 XS_SHOW_STATISTICS_IN_DX

Category: Model views

Use this advanced option to show statistics and the used rendering device in the DirectX rendered model views. The statistics are shown in the lower left corner of the model view, as frames per second measurement.

With this advanced option you can easily verify that you are using a proper graphics hardware accelerator for the Tekla Structures model views, especially in the case of multiple GPUs such as laptops, which often have both CPU built accelerator and an external, much more powerful graphics accelerator

By default, the advanced option is set to `FALSE`.

If you change the value, you need to reopen the view to activate the new value.

Note that this advanced option has no effect on the legacy OpenGL rendered model views.

19.47 XS_SHOW_STUDS_IN_WORKSHOP_DRAWINGS

Category

Drawing Properties

Set this advanced option to `TRUE` to show workshop studs in single-part drawings. The default value is `FALSE`.

This advanced option is model specific and the setting is saved in the options database.

19.48 XS_SHOW_TEMPLATE_LOG_MESSAGES

Category

Templates and Symbols

Set this advanced option to `TRUE` to show error messages related to template attributes in the log file. Set it to `FALSE` to hide these messages. By default this advanced option is set to `FALSE`.

This advanced option is user specific and the setting is saved in `options.bin` under the user folder, for example, in `C:\Users\\AppData\Local\Trimble\Tekla Structures\\UserSettings`. Restart Tekla Structures to activate the new value.

19.49 XS_SINGLE_CENTERED_SCREW

Category: Single-part views in assembly drawings

Use to control the dimensioning of centrally-located bolts in single-part views included in assembly drawings in integrated dimensioning. Possible values are:

- 0 = Dimensions the centered bolts spread.
- 5 = Dimensions the bolts to the main part center-lines.
- 6 = Overrides the **Secondary part bolt internal dimensions** setting for centered bolts. This only applies to bolts located centrally on the part.

This advanced option is model specific and the setting is saved in the options database.

19.50 XS_SINGLE_CLOSE_DIMENSIONS

Category: Single-part views in assembly drawings

Use to close dimensions in single-part views included in an assembly drawing.

- 0 = Does not close dimensions

- 1 = Closes dimensions in the x direction and leaves others open. This is the default value.
- 2 = Closes all dimensions

This advanced option is model specific and the setting is saved in the options database.

19.51 XS_SINGLE_CLOSE_SHORT_DIMENSIONS

Category: Single-part views in assembly drawings

Use to close short dimensions in single-part views included in assembly drawings. The default value is 1. If you do not want to close short dimensions, enter 0.

This advanced option is model specific and the setting is saved in the options database.

19.52 XS_SINGLE_COMBINE_DISTANCE

Category: Single-part views in assembly drawings

Use to set a distance for combining dimensions in single-part views included in assembly drawings. Enter a decimal value, for example 400.0.

By default, this advanced option is not set to any value.

This advanced option is model specific and the setting is saved in the options database.

19.53 XS_SINGLE_COMBINE_MIN_DISTANCE

Category: Single-part views in assembly drawings

Use to set a minimum distance for combining dimensions in single-part views included in assembly drawings. Enter a decimal value, for example 200.0.

By default, this advanced option is not set to any value.

This advanced option is model specific and the setting is saved in the options database.

19.54 XS_SINGLE_COMBINE_WAY

Category: Single-part views in assembly drawings

Use to combine dimensions in single-part views included in assembly drawings. The options correspond to the combining order on the General tab of the **Dimensioning Properties** dialog box. By default, this advanced option is not set to any value.

- Option 0 prevents dimensions from being combined.
- Option 1 combines part position dimensions with part internal dimensions, and bolt group internal dimensions with bolt edge distances. Bolt position dimensions are not combined with bolt internal dimensions.
- Option 2 combines the part position dimension with part internal dimensions and bolt group internal dimensions. Bolt internal dimensions are combined with bolt position dimensions. Edge distances are shown separately.
- Option 3 combines bolt internal dimensions and position dimensions in the same dimension line.
- Option 4 combines bolt group position dimensions with part position dimensions. Part and bolt internal dimensions are not combined with this option, but bolt internal dimensions are combined with bolt edge distances.
- Option 5 combines internal dimensions and the position dimension of bolt groups where there are several bolt groups.
- Option 4.5 uses a combination of option 5 for the main part and a combination of option 4 for the secondary parts.

This advanced option is model specific and the setting is saved in the options database.

19.55 XS_SINGLE_DIMENSION_TYPE

Category: Single-part views in assembly drawings

Use to set a dimension type for single-part views included in assembly drawings. The options are:

- 1 = Relative, point to point dimensions. This is the default value.
- 2 = Absolute, dimensions from a common start point.
- 3 = Relative and absolute, a combination of point to point and common start point.
- 4 = US absolute, dimensions from a common start point, which include a running dimension mark (RD).

- 16 = US absolute 2, similar to US absolute, but it changes short dimensions to relative.
- 35 = Absolute plus short relatives, which is similar to Absolute, but it changes short dimensions to relative. Also called internal absolute. This option may show both dimensions, but it does not show relative dimensions when dimensions are long. This option shows the absolute dimensions inside the dimension lines.
- 99 = Absolute plus all relatives above the absolutes, which is similar to Relative and absolute, but it places the relative dimensions above the absolute.

This advanced option is model specific and the setting is saved in the options database.

19.56 XS_SINGLE_DRAW_PART_AS

Category: Single-part views in assembly drawings

Use to define how parts appear (their representation type) in single-part views included in assembly drawings. The options are:

- 1 (default) solid
- 4 workshop solid (round tubes open)
- 2 symbol form

This advanced option is model specific and the setting is saved in the options database.

19.57 XS_SINGLE_EXCLUDE

Category: Single-part views in assembly drawings

Use to exclude single-part views from assembly drawings. The options are:

- NONE includes all single part views.
- MAIN_SHAFT includes single part views of all parts, except assembly main parts.
- ALL_SHAFTS includes single part views of all parts, except those with another object welded to them (i.e. main parts).
- AUTO (default) includes single part views of all parts, except the longest main part in the assembly.
- ALL_BUT_MAIN_PART includes single part views of assembly main parts only.

- `STANDARD` includes single-part views of all parts, except standard parts. You can add `STANDARD` after any of the existing values, for example `MAIN_SHAFT_AND_STANDARD` creates single-part drawing from all but main part or standard parts.

This advanced option is model specific and the setting is saved in the options database.

19.58 XS_SINGLE_FORWARD_OFFSET

Category: Single-part views in assembly drawings

Use to set the distance Tekla Structures uses to search for the base point of a dimension in single-part views included in an assembly drawing. If Tekla Structures does not find a base point (corner) within the defined forward offset search distance, it uses an edge point. Enter the value as a decimal, for example `250.0`.

This advanced option is model specific and the setting is saved in the options database.

19.59 XS_SINGLE_NO_RELATIVE_SHAPE_DIMENSIONS

Category

Dimensioning: Parts

Set this advanced option to `TRUE` (default) to force shape dimensions to be the same as the dimension type you select. If you do not want to do this, set it to `FALSE`.

This advanced option is model specific and the setting is saved in the options database.

See also

[XS_NO_RELATIVE_SHAPE_DIMENSIONS \(page 313\)](#)

19.60 XS_SINGLE_NO_SHORTEN

Category: Single-part views in assembly drawings

Set this advanced option to `TRUE` to display single-part views in drawings without shortening parts. The default value is `FALSE`.

This advanced option is model specific and the setting is saved in the options database.

19.61 XS_SINGLE_ORIENTATION_MARK

Category: Single-part views in assembly drawings

You can display orientation symbols in single-part views included in assembly drawings. To show the orientation symbols in single-part views, set this advanced option to `TRUE`.

In assembly drawing properties, do the following:

1. In assembly drawing properties, click **Layout** and go to the **Other** tab.
2. Set the option **Single-part attributes** to **Current attributes**. Tekla Structures takes the orientation mark settings from the current single-part drawing properties. If you select other attributes, the visibility of the orientation symbols is set according to the selected attribute file.

The default value is `FALSE`.

This advanced option is model specific and the setting is saved in the options database.

19.62 XS_SINGLE_PART_DRAWING_VIEW_TITLE

Category: Drawing properties

Use to define a title for single-part drawing views in multidrawings. You can use any of the following to define the title:

Enter any combination of text and options, and enclose each option in percent symbols (%).

Example: No. %MODEL_NUMBER%, Marked %PART_POS%

The options are:

- PART_NAME
- PART_MATERIAL
- PART_POS

- ASSEMBLY_POS
- MODEL_NUMBER
- LENGTH
- PROFILE
- MAIN_PART_LENGTH
- DRAWING_BASE_NAME
- DRAWING_NAME

This advanced option is model specific and the setting is saved in the options database.

19.63 XS_SINGLE_PART_EXTREMA

Category: Single-part views in assembly drawings

Use to display overall dimensions in single-part views included in assembly drawings. Enter one of the following values:

- 0 = None
- 2 = Once
- 3 = All

This advanced option is model specific and the setting is saved in the options database.

19.64 XS_SINGLE_PART_SHAPE

Category: Single-part views in assembly drawings

Use to show or hide shape dimensions in single part views in assembly drawings.

Set to 1 (default) to show shape dimensions in single-part views.

Set to 0 to hide shape dimensions in single-part views.

Tekla Structures automatically creates radius dimensions for curved chamfers in single-part drawings when you use shape dimensions.

This advanced option is model specific and the setting is saved in the options database.

19.65 XS_SINGLE_SCALE

Category: Single-part views in assembly drawings

Use to set the scale of single-part views included in assembly drawings. Enter a decimal value. By default, this advanced option is not set to any value.

This advanced option is model specific and the setting is saved in the options database.

Example

To have Tekla Structures use the scale 1/10, enter 10.0.

This advanced option is related to the advanced option [XS_USE_EXISTING_SINGLE_PART_DRAWINGS_SCALE](#) (page 476).

19.66 XS_SINGLE_SCREW_INTERNAL

Category: Single-part views in assembly drawings

Use to show or hide internal bolt dimensions in single part views included in assembly drawings.

Set to 1 to show internal bolt dimensions.

Set to 0 to hide internal bolt dimensions.

By default, this advanced option is not set to any value.

This advanced option is model specific and the setting is saved in the options database.

19.67 XS_SINGLE_SCREW_POSITIONS

Category: Single-part views in assembly drawings

Use to include position dimensions for bolts in single-part views included in assembly drawings. Enter one of the following values:

- 0 = Off
- 1 = On

This advanced option is model specific and the setting is saved in the options database.

19.68 XS_SINGLE_USE_WORKING_POINTS

Category: Single-part views in assembly drawings

Use to include dimensions from work points in single-part views included in assembly drawings. Enter one of the following values:

- 0 = None (default)
- 1 = Main part
- 2 = Working points
- 3 = Both

This advanced option is model specific and the setting is saved in the options database.

19.69 XS_SINGLE_X_DIMENSION_TYPE

Category: Single-part views in assembly drawings

Use to set the dimension type for single-part views included in assembly drawings. These are otherwise like straight dimensions set with the advanced option `XS_SINGLE_X_DIMENSION_TYPE` but they override the straight setting for horizontal dimensions.

- 0 = Tekla Structures uses straight dimension settings
- 1 = Relative, point to point dimensions. This is the default value.
- 2 = Absolute, dimensions from a common start point.
- 3 = Relative and absolute, a combination of point to point and common start point.
- 4 = US absolute, dimensions from a common start point, which include a running dimension mark (RD).
- 16 = US absolute 2, similar to US absolute, but it changes short dimensions to relative.
- 35 = Absolute plus short relatives, which is similar to Absolute, but it changes short dimensions to relative. Also called internal absolute. This option may show both dimensions, but it does not show relative dimensions when dimensions are long. This option shows the absolute dimensions inside the dimension lines.
- 99 = Absolute plus all relatives above the absolutes, which is similar to Relative and absolute, but it places the relative dimensions above the absolute.

This advanced option is model specific and the setting is saved in the options database.

19.70 XS_SITE_BOLT_MARK_STRING_FOR_SIZE

Category: Marking - bolts

Use to define the contents of the **Size** element in bolt marks (site). The default value is `%BOLT_NUMBER%*D%HOLE.DIAMETER%`.

This advanced option is only used when there is a bolt and the hole is a normal one.

You can use any combination of text and the following options as the value for this advanced option. You can use the options in any order, and make calculations.

- BOLT_NUMBER
- DIAMETER
- LENGTH
- HOLE.DIAMETER
- LONG_HOLE_X
- LONG_HOLE_Y
- LONGHOLE_MIN (the shorter of the slotted hole dimensions)
- LONGHOLE_MAX (the longer of the slotted hole dimensions)
- BOLT_STANDARD
- BOLT_MATERIAL
- BOLT_ASSEMBLY_TYPE
- BOLT_COUNTERSUNK
- BOLT_SHORT_NAME
- BOLT_FULL_NAME

Enclose each option in % characters.

Note that if you are defining this advanced option in an `.ini` file, use double percent signs around the options. For example, `%%BOLT_NUMBER%%*D%HOLE.DIAMETER%%`.

To use special characters, enter a backslash (\) followed by an ASCII number.

With length-type options, but not in calculations, you can specify the number of decimals. For example, `HOLE.DIAMETER.2` shows (tapped) hole diameters with two decimals.

This advanced option is model specific and the setting is saved in the options database.

19.71 XS_SITE_BOLT_MARK_STRING_FOR_SIZE_IN_GA

Category: Marking - bolts

Use to define the contents of the size element in bolt marks for site bolts in general arrangement drawings.

This advanced option is only used when there is a bolt and the hole is a normal one.

You can use any combination of text and the following options as the value for this advanced option. You can use the options in any order, and make calculations.

- BOLT_NUMBER
- DIAMETER
- LENGTH
- HOLE.DIAMETER
- LONG_HOLE_X
- LONG_HOLE_Y
- LONGHOLE_MIN (the shorter of the slotted hole dimensions)
- LONGHOLE_MAX (the longer of the slotted hole dimensions)
- BOLT_STANDARD
- BOLT_MATERIAL
- BOLT_ASSEMBLY_TYPE
- BOLT_COUNTERSUNK
- BOLT_SHORT_NAME
- BOLT_FULL_NAME

Enclose each option in % characters.

Note that if you are defining this advanced option in an `.ini` file, use double percent signs around the options. For example, `%%BOLT_NUMBER%%*D%
%HOLE.DIAMETER%%.`

To use special characters, enter a backslash (\) followed by an ASCII number.

With length-type options, but not in calculations, you can specify the number of decimals. For example, `HOLE.DIAMETER.2` shows (tapped) hole diameters with two decimals.

This advanced option is model specific and the setting is saved in the options database.

See also

[XS_SITE_HOLE_MARK_STRING_FOR_SIZE_IN_GA \(page 435\)](#)

[XS_SITE_LONGHOLE_MARK_STRING_FOR_SIZE_IN_GA \(page 437\)](#)

19.72 XS_SITE_HOLE_MARK_STRING_FOR_SIZE

Category: Marking - bolts

Use to define the contents of the **Size** element in hole marks (site). For example, to show bolt number and hole diameter in the mark, enter `%BOLT_NUMBER%*D%HOLE.DIAMETER%`.

This advanced option is only used when there is a hole, no bolt (and the hole is a normal one).

You can use any combination of text and the following options as the value for this advanced option. You can use the options in any order, and make calculations.

- BOLT_NUMBER
- DIAMETER
- LENGTH
- HOLE.DIAMETER
- LONG_HOLE_X
- LONG_HOLE_Y
- LONGHOLE_MIN (the shorter of the slotted hole dimensions)
- LONGHOLE_MAX (the longer of the slotted hole dimensions)
- BOLT_STANDARD
- BOLT_MATERIAL
- BOLT_ASSEMBLY_TYPE
- BOLT_COUNTERSUNK
- BOLT_SHORT_NAME
- BOLT_FULL_NAME

Enclose each option in % characters.

Note that if you are defining this advanced option in an `.ini` file, use double percent signs around the options. For example, `%%BOLT_NUMBER%%*D%
%HOLE.DIAMETER%%`.

To use special characters, enter a backslash (\) followed by an ASCII number.

With length-type options, but not in calculations, you can specify the number of decimals. For example, `HOLE.DIAMETER.2` shows (tapped) hole diameters with two decimals.

This advanced option is model specific and the setting is saved in the options database.

19.73 XS_SITE_HOLE_MARK_STRING_FOR_SIZE_IN_GA

Category: Marking - bolts

Use to define the contents of the size element in hole marks for site bolts in general arrangement drawings.

This advanced option is only used when there is a hole, no bolt (and the hole is a normal one).

You can use any combination of text and the following options as the value for this advanced option. You can use the options in any order, and make calculations.

- BOLT_NUMBER
- DIAMETER
- LENGTH
- HOLE.DIAMETER
- LONG_HOLE_X
- LONG_HOLE_Y
- LONGHOLE_MIN (the shorter of the slotted hole dimensions)
- LONGHOLE_MAX (the longer of the slotted hole dimensions)
- BOLT_STANDARD
- BOLT_MATERIAL
- BOLT_ASSEMBLY_TYPE
- BOLT_COUNTERSUNK
- BOLT_SHORT_NAME
- BOLT_FULL_NAME

Enclose each option in % characters.

Note that if you are defining this advanced option in an `.ini` file, use double percent signs around the options. For example, `%%BOLT_NUMBER%%*D%
%HOLE.DIAMETER%%`.

To use special characters, enter a backslash (\) followed by an ASCII number.

With length-type options, but not in calculations, you can specify the number of decimals. For example, `HOLE.DIAMETER.2` shows (tapped) hole diameters with two decimals.

This advanced option is model specific and the setting is saved in the options database.

See also

[XS_SITE_BOLT_MARK_STRING_FOR_SIZE_IN_GA](#) (page 433)

[XS_SITE_LONGHOLE_MARK_STRING_FOR_SIZE_IN_GA](#) (page 437)

19.74 XS_SITE_LONGHOLE_MARK_STRING_FOR_SIZE

Category: Marking - bolts

Use to define the contents of the **Size** element in slotted hole marks (site). The default value is `%BOLT_NUMBER%*D%HOLE.DIAMETER% (%HOLE.DIAMETER
+LONGHOLE_MIN%x%HOLE.DIAMETER+LONGHOLE_MAX%)`.

This advanced option is only used when there is a slotted hole.

You can use any combination of text and the following options as the value for this advanced option. You can use the options in any order, and make calculations.

- BOLT_NUMBER
- DIAMETER
- LENGTH
- HOLE.DIAMETER
- LONG_HOLE_X
- LONG_HOLE_Y
- LONGHOLE_MIN (the shorter of the slotted hole dimensions)
- LONGHOLE_MAX (the longer of the slotted hole dimensions)
- BOLT_STANDARD
- BOLT_MATERIAL
- BOLT_ASSEMBLY_TYPE

- BOLT_COUNTERSUNK
- BOLT_SHORT_NAME
- BOLT_FULL_NAME

Enclose each option in % characters.

Note that if you are defining this advanced option in an `.ini` file, use double percent signs around the options. For example, `%%BOLT_NUMBER%%*D%
%HOLE.DIAMETER%%`.

To use special characters, enter a backslash (\) followed by an ASCII number.

With length-type options, but not in calculations, you can specify the number of decimals. For example, `HOLE.DIAMETER.2` shows (tapped) hole diameters with two decimals.

This advanced option is model specific and the setting is saved in the options database.

19.75 XS_SITE_LONGHOLE_MARK_STRING_FOR_SIZE_IN_GA

Category: Marking - bolts

Use to define the contents of the size element in longhole marks for site bolts in general arrangement drawings.

This advanced option is only used when there is a slotted hole.

You can use any combination of text and the following options as the value for this advanced option. You can use the options in any order, and make calculations.

- BOLT_NUMBER
- DIAMETER
- LENGTH
- HOLE.DIAMETER
- LONG_HOLE_X
- LONG_HOLE_Y
- LONGHOLE_MIN (the shorter of the slotted hole dimensions)
- LONGHOLE_MAX (the longer of the slotted hole dimensions)
- BOLT_STANDARD
- BOLT_MATERIAL
- BOLT_ASSEMBLY_TYPE
- BOLT_COUNTERSUNK

- BOLT_SHORT_NAME
- BOLT_FULL_NAME

Enclose each option in % characters.

Note that if you are defining this advanced option in an `.ini` file, use double percent signs around the options. For example, `%%BOLT_NUMBER%%*D%%HOLE.DIAMETER%%`.

To use special characters, enter a backslash (\) followed by an ASCII number.

With length-type options, but not in calculations, you can specify the number of decimals. For example, `HOLE.DIAMETER.2` shows (tapped) hole diameters with two decimals.

This advanced option is model specific and the setting is saved in the options database.

See also

[XS_SITE_HOLE_MARK_STRING_FOR_SIZE_IN_GA \(page 435\)](#)

[XS_SITE_BOLT_MARK_STRING_FOR_SIZE_IN_GA \(page 433\)](#)

19.76 XS_SITE_OVERSIZEDHOLE_MARK_STRING_FOR_SIZE

Category: Marking - bolts

Use to define the contents of the **Size** element in marks for oversized bolt holes (site). The default value is `%BOLT_NUMBER%*D%HOLE.DIAMETER%`.

This advanced option is only used when there is an oversized hole.

You can use any combination of text and the following options as the value for this advanced option. You can use the options in any order, and make calculations.

- BOLT_NUMBER
- DIAMETER
- LENGTH
- HOLE.DIAMETER
- LONG_HOLE_X
- LONG_HOLE_Y
- LONGHOLE_MIN (the shorter of the slotted hole dimensions)
- LONGHOLE_MAX (the longer of the slotted hole dimensions)
- BOLT_STANDARD
- BOLT_MATERIAL

- BOLT_ASSEMBLY_TYPE
- BOLT_COUNTERSUNK
- BOLT_SHORT_NAME
- BOLT_FULL_NAME

Enclose each option in % characters.

Note that if you are defining this advanced option in an `.ini` file, use double percent signs around the options. For example, `%%BOLT_NUMBER%%*D%%HOLE.DIAMETER%%`.

To use special characters, enter a backslash (\) followed by an ASCII number.

With length-type options, but not in calculations, you can specify the number of decimals. For example, `HOLE.DIAMETER.2` shows (tapped) hole diameters with two decimals.

This advanced option is model specific and the setting is saved in the options database.

See also

[XS_SHOP_OVERSIZEDHOLE_MARK_STRING_FOR_SIZE](#) (page 412)

[XS_SITE_OVERSIZEDHOLE_MARK_STRING_FOR_SIZE_IN_GA](#) (page 439)

19.77 XS_SITE_OVERSIZEDHOLE_MARK_STRING_FOR_SIZE_IN_GA

Category: Marking - bolts

Use to define the contents of the **Size** element in oversized hole marks for site bolts in general arrangement drawings.

This advanced option is only used when there is an oversized hole.

You can use any combination of text and the following options as the value for this advanced option. You can use the options in any order, and make calculations.

- BOLT_NUMBER
- DIAMETER
- LENGTH
- HOLE.DIAMETER
- LONG_HOLE_X
- LONG_HOLE_Y
- LONGHOLE_MIN (the shorter of the slotted hole dimensions)

- LONGHOLE_MAX (the longer of the slotted hole dimensions)
- BOLT_STANDARD
- BOLT_MATERIAL
- BOLT_ASSEMBLY_TYPE
- BOLT_COUNTERSUNK
- BOLT_SHORT_NAME
- BOLT_FULL_NAME

Enclose each option in % characters.

Note that if you are defining this advanced option in an `.ini` file, use double percent signs around the options. For example, `%%BOLT_NUMBER%%*D%%HOLE.DIAMETER%%`.

To use special characters, enter a backslash (\) followed by an ASCII number.

With length-type options, but not in calculations, you can specify the number of decimals. For example, `HOLE.DIAMETER.2` shows (tapped) hole diameters with two decimals.

This advanced option is model specific and the setting is saved in the options database.

See also

[XS_SHOP_OVERSIZEDHOLE_MARK_STRING_FOR_SIZE_IN_GA](#) (page 413)

[XS_SITE_OVERSIZEDHOLE_MARK_STRING_FOR_SIZE](#) (page 438)

19.78 XS_SITE_TAPPEDHOLE_MARK_STRING_FOR_SIZE

Category: Marking - bolts

Use to define the contents of the **Size** element in marks for tapped bolt holes (site). The default value is `%%BOLT_NUMBER%%*\216%%HOLE.DIAMETER.1% TAP M %%BOLT_DIAMETER%%`.

This advanced option is only used when there is a tapped hole.

You can use any combination of text and the following options as the value for this advanced option. You can use the options in any order, and make calculations.

- BOLT_NUMBER
- DIAMETER
- LENGTH
- HOLE.DIAMETER

- LONG_HOLE_X
- LONG_HOLE_Y
- LONGHOLE_MIN (the shorter of the slotted hole dimensions)
- LONGHOLE_MAX (the longer of the slotted hole dimensions)
- BOLT_STANDARD
- BOLT_MATERIAL
- BOLT_ASSEMBLY_TYPE
- BOLT_COUNTERSUNK
- BOLT_SHORT_NAME
- BOLT_FULL_NAME

Enclose each option in % characters.

Note that if you are defining this advanced option in an `.ini` file, use double percent signs around the options. For example, `%%BOLT_NUMBER%%*D%%HOLE.DIAMETER%%`.

To use special characters, enter a backslash (\) followed by an ASCII number.

With length-type options, but not in calculations, you can specify the number of decimals. For example, `HOLE.DIAMETER.2` shows (tapped) hole diameters with two decimals.

This advanced option is model specific and the setting is saved in the options database.

See also

[XS_SHOP_TAPPEDHOLE_MARK_STRING_FOR_SIZE](#) (page 414)

[XS_SITE_TAPPEDHOLE_MARK_STRING_FOR_SIZE_IN_GA](#) (page 441)

19.79 XS_SITE_TAPPEDHOLE_MARK_STRING_FOR_SIZE_IN_GA

Category: Marking - bolts

Use to define the contents of the **Size** element in tapped hole marks for site bolts in general arrangement drawings.

This advanced option is only used when there is a tapped hole.

You can use any combination of text and the following options as the value for this advanced option. You can use the options in any order, and make calculations.

- BOLT_NUMBER
- DIAMETER

- LENGTH
- HOLE.DIAMETER
- LONG_HOLE_X
- LONG_HOLE_Y
- LONGHOLE_MIN (the shorter of the slotted hole dimensions)
- LONGHOLE_MAX (the longer of the slotted hole dimensions)
- BOLT_STANDARD
- BOLT_MATERIAL
- BOLT_ASSEMBLY_TYPE
- BOLT_COUNTERSUNK
- BOLT_SHORT_NAME
- BOLT_FULL_NAME

Enclose each option in % characters.

Note that if you are defining this advanced option in an `.ini` file, use double percent signs around the options. For example, `%%BOLT_NUMBER%%*D%%
%HOLE.DIAMETER%%`.

To use special characters, enter a backslash (\) followed by an ASCII number.

With length-type options, but not in calculations, you can specify the number of decimals. For example, `HOLE.DIAMETER.2` shows (tapped) hole diameters with two decimals.

This advanced option is model specific and the setting is saved in the options database.

See also

[XS_SHOP_TAPPEDHOLE_MARK_STRING_FOR_SIZE_IN_GA](#) (page 415)

[XS_SITE_TAPPEDHOLE_MARK_STRING_FOR_SIZE](#) (page 440)

19.80 XS_SKIP_START_UP_SIGNIN_ON_PREMISE_LICENSING

This advanced option `XS_SKIP_START_UP_SIGNIN_ON_PREMISE_LICENSING` skips the sign in dialog box during the Tekla Structures start-up when you set it to `TRUE`. It is especially useful if you use on-premises licenses and do not want to or cannot sign in.

This advanced option must be read by Tekla Structures in the early stages of starting up. You can set it as [a Windows environment variable, in a batch file](#), or in `bypass.ini`.

19.81 XS_SNAPSHOT_DIRECTORY

Category: File Locations

Use this advanced option to define the folder where Tekla Structures stores screenshots when you go to the **View** tab (**Views** in drawings) and click **Screenshot** --> **Screenshot** . If you do not define a path, Tekla Structures stores screenshots in the current model folder. The default value is `.\screenshots\`.

If the defined folder does not exist, Tekla Structures automatically creates it when you take a screenshot.

This advanced option is user specific and the setting is saved in `options.bin` under the user folder, for example, in `C:\Users\\AppData\Local\Trimble\Tekla Structures\\UserSettings`. Restart Tekla Structures to activate the new value.

Example

```
c:\temp\
```

19.82 XS_SOLID_BUFFER_SIZE

Category: Speed and accuracy

Use this advanced option to define the size of the solid object buffer. The value is the number of simple average solids. The buffer size setting depends on your environment.

Tekla Structures creates a buffer in system RAM to store the solid representation of parts it creates during certain processes. For example, Tekla Structures creates solid objects when numbering a model. When this buffer fills up, Tekla Structures erases the contents in order to continue using the buffer.

When you increase the buffer size, Tekla Structures keeps more solid objects in the memory, and does not have to recreate them so often. Increasing this value also increases the memory used by the processes. Decreasing this value decreases the memory requirements, but also the performance as Tekla Structures has to recreate solid objects more often.

Testing various settings is the best way to optimize the solid object buffer size. Remember that opening Tekla Structures windows uses some RAM, and that other programs also use RAM for various processes.

For optimum performance for large models under restricted memory conditions, consider having the solid cache size in between $0.2 - 5 * \text{the}$

number of parts in your model. To find out the number of parts in the model, go to the **Edit** tab and click **Inquire --> Model size** .

In 64-bit machines you do not usually have to change the default value. If the amount of memory is large, keep the buffer size at least as large as the number of parts in the model.

This advanced option is user specific and the setting is saved in `options.bin` under the user folder, for example, in `C:\Users\\AppData\Local\Trimble\Tekla Structures\\UserSettings`. Restart Tekla Structures to activate the new value.

19.83 XS_SOLID_USE_HIGHER_ACCURACY

This advanced option must be set in an initialization (.ini) file.

NOTE This advanced option increases the number of faces in solid objects, which slows down Tekla Structures. We recommend using this advanced option only when needed.

When you set this advanced option to `TRUE` in the `options.ini` file in the model folder:

- When you have set part representation to **Exact** in the **Display** dialog box, parts are shown with roundings. Also weld polygons include profile roundings.
- When the advanced option [XS_DISPLAY_FILLET_EDGES \(page 143\)](#) is set to `TRUE`, lines are shown between the roundings and straight segments of parts.
- Part volume, area and net weight is and are closer to real manufactured values.

Set this advanced option to `TRUE` in the `options.ini` file in model folder. The default value is `FALSE`.

Limitations

- Do not activate this advanced option when you create NC/DSTV files, because it can lead to inaccuracies in the exported data.
- Do not activate this advanced option when you create single part or assembly drawings, because it can lead to unnecessary dimension line creation.
- In components, some stiffeners might bite into flanges of columns or beams.
- Some bolt edge distances are not correctly calculated.

See also

[XS_CS_CHAMFER_DIVIDE_ANGLE](#) (page 111)

19.84 XS_STACKED_FRACTION_TYPE

Category

Imperial units

Use to define the appearance of fractions. You can use stacked fractions in drawings, text, marks etc., but not in templates. The options are (from left to right in the illustration):

1/16 $\frac{1}{16}$ 1/16 1₁₆

- NOT_STACKED
- DASH
- SLASH
- WITHOUT_SLASH

If you do not want to use stacked fractions, set this advanced option to NOT_STACKED, (default) or use a backslash character (\) before the slash character (/) in the text (e.g. 1\16).

This advanced option is model specific and the setting is saved in the options database.

19.85 XS_STANDARD_GUSSET_WIDTH_TOLERANCE

Category

Components

Use to define the tolerance between the actual and standard widths of gusset plates created using modeling tools or connections. Tekla Structures uses a standard plate file to define the default plate width including the tolerance value. Enter the value in millimeters, for example 1.0.

Components that use this advanced option are:

- **Welded gusset (10)**
- **Bolted gusset (11)**
- **Tube gusset (20)**

- **Corner tube gusset (56)**
- **Corner bolted gusset (57)**
- **Wraparound gusset (58)**
- **Hollow brace wraparound gusset (59)**
- **Wraparound gusset cross (60)**
- **Gusseted cross (62)**
- **Corner wrapped gusset (63)**

This advanced option is model specific and the setting is saved in the options database.

19.86 XS_STANDARD_STIFFENER_WIDTH_TOLERANCE

Category: Components

Use to define the tolerance between the actual and standard widths of stiffener plates created by **Stiffened shear plate (17)**, **Haunch (40)**, **Beam with stiffeners (129)**, **Column with shear plate (131)**, **Bolted moment connection (134)**, **Beam to beam stub (135)**, **Clip angle (141)**, **Bent plate (151)**, **Moment connection (181)**, **Column with stiffeners W (182)**, **Column with stiffeners (186)**, **Column with stiffeners S (187)**, **Stiffeners (1003)**, **Stub (28)**, **Web stiffened base plate (1016)**, and **Multiple stiffeners (1064)**.

Enter the value in millimeters. Do not use the value 0. The advanced option is set to 10 by default.

This advanced option is model specific and the setting is saved in the options database.

19.87 XS_STD_LOCALE

This advanced option is system specific and should be set in the lang_<CurrentLanguage>.ini files.

Use this advanced option to be able to open drawings in a situation where you have English Tekla Structures and multi-byte locale Windows operating system. Set it to one of the following values in the `teklastructures.ini` file, depending on the locale of your operating system:

- `set XS_STD_LOCALE=japanese`
- `set XS_STD_LOCALE=chinese-traditional`
- `set XS_STD_LOCALE=chinese-simplified`

- `set XS_STD_LOCALE=russian_us.1251`
- `set XS_STD_LOCALE=korean_korea.949`

If you set `XS_STD_LOCALE` to any other value, or leave the value out, English locale is used by default.

NOTE For more information on locales, see <https://msdn.microsoft.com/en-us/library/ms903928.aspx>.

19.88 XS_STD_PART_MODEL

Category

Numbering

To use standard parts in numbering, enter the standard part model folder path. A standard-part model contains only standard parts with specific part prefixes. As Tekla Structures carries out the numbering, it compares all of the parts in the current model to the standard-part model. The numbering applies any part position numbers (only the part prefix) found in the standard-part model to all identical parts found in the current model. To not use standard parts, leave the value out.

This advanced option is model specific and the setting is saved in the options database.

Example

```
XS_STD_PART_MODEL=C:\TeklaStructuresModels\StandardParts\
```

See also

19.89 XS_STEEL1_TS_PAGE_9_EXTENSION

Category

This advanced option must be set in an initialization (.ini) file.

Used for localizing the contents of Component page 9. By default standard component settings are used. For example, in the USA environment, you can use the value `_usimp`.

19.90 XS_STEEL1_TS_PAGE_10_EXTENSION

Category

This advanced option must be set in an initialization (.ini) file.

Used for localizing the contents of Component page 10 (catalog steps in stair components). By default standard component settings are used.

Step profiles are coming from `steps.dat` file, which is environment specific. To get a profile visible in the catalogue step/step profile list in the **Stairs** component dialog box, the names of the profiles have to be listed also in the environment-specific `.inp` file in the `\TeklaStructures\<>version>\applications\steel1` folder. There are different files for each environment: `ts_page_10_australasia.inp`, `ts_page_10_austria.inp`, `ts_page_10_china.inp`, and so on. For example, in the USA environment, you can use the value `_usimp` for this advanced option.

Affected stair components and options:

- **Stairs (S71)**: Stair setup tab: Catalogue step
- **Stairs (S82)**: Parameters tab: Step profile



For Stairs S71, the **Step type** must be set to **Catalogue step**, to be able to select the step profile from the **Catalogue step** list.

19.91 XS_STORE_MULTIPLE_BAK_FILES

Category

File Locations

Set this advanced option to `TRUE` to store multiple versions of the backup copy of the model database. The default value is `FALSE`.

A new copy of the `.bak` backup file is created each time the model is saved. The name of each backup file includes the date and time the file was created. Old or unnecessary files need to be deleted manually.

19.92 XS_SUPERSCRIPT_HEIGHT_FACTOR

Category: Dimensioning - general

Use this advanced option to set the scale factor for the text height in superscripts used in dimensions. The default is 0.7.

This advanced option is model specific and the setting is saved in the options database.

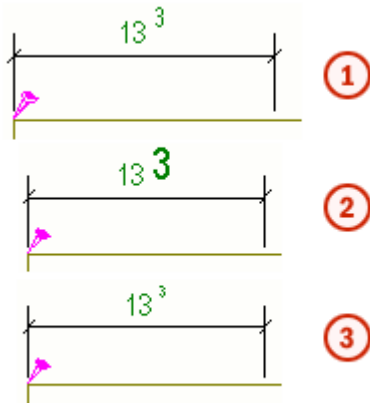

(1) 0.7

(2) 1.5

(3) 0.5

19.93 XS_SUPERSCRIPT_USED_IN_DRAWING_TEXTS

Category

Dimensioning: General

Set to `TRUE` to enable the showing of superscript in texts in drawings, and to `FALSE` to disable it. The default is `TRUE`.

This advanced option is model specific and the setting is saved in the options database.

19.94 XS_SUPPORT_TOOL_EXCLUDE_ALL_FILES

This advanced option must be set in the `user.ini` or `teklastructures.ini` file.

Use this advanced option to prevent the support tool from preselecting all files for sending in your support request. By default, Tekla Structures selects all files, which might cause problems with large models. Note that this advanced option does not work if you define it in the `options.ini` file.

19.95 XS_SWITCH_MULTI_NUMBERS_FOR

Category: Numbering

Use to define the order in which multidrawing numbers, and part or assembly numbers appear in multi-numbers. The options are: `NONE`, `ASSEMBLIES`, `PARTS` and `ASSEMBLIES_AND_PARTS`. The default value is `ASSEMBLIES_AND_PARTS`.

This advanced option is model specific and the setting is saved in the options database.

Example

If this advanced option is set to `PARTS`, the presentation of multinumbers for parts is 101a, not a101.

See also

[XS_USE_MULTI_NUMBERING_FOR](#) (page 480)

19.96 XS_SWITCH_POS_NUMBERS_FOR

Category

Numbering

Changes the prefix you define for Tekla Structures assembly and/or part marks to a suffix (for example, A1 becomes 1A). The options are `NONE`, `PARTS`, `ASSEMBLIES`, and `ASSEMBLIES_AND_PARTS`. The default value is `ASSEMBLIES_AND_PARTS`.

NOTE The advanced options [XS_ASSEMBLY_POSITION_NUMBER_FORMAT_STRING](#) (page 58) and [XS_PART_POSITION_NUMBER_FORMAT_STRING](#) (page 328) override the advanced option `XS_SWITCH_POS_NUMBERS_FOR`. `XS_SWITCH_POS_NUMBERS_FOR` has

no impact on assembly and/or part position numbers if you use
XS_ASSEMBLY_POSITION_NUMBER_FORMAT_STRING and/or
XS_PART_POSITION_NUMBER_FORMAT_STRING.

This advanced option is model specific and the setting is saved in the options database.

19.97 SYMEDHOME

Category: Templates and symbols

Points to the location of the Symbol Editor program file `symed.exe`. The default value is `%XSBIN%`.

This advanced option is system specific and is read from environment files. Generally, there is no need to modify system-specific settings. Do not modify them if you are not an administrator.

19.98 XS_SYSTEM

Category: File locations

NOTE This advanced option is only meant for administrators.

It points to the location of the Tekla Structures system folder. The system folder is used for storing files that define default settings. These include the standard, data (.dat), property files, drawing files, template files, and report files, for example.

Specifying more than one system folder

You can specify more than one system folder, and this way define specific settings for each role. Use the role options defined in the `env_<environment>.ini` file to point to the roles when specifying the system folders in `XS_SYSTEM`. For example, `XS_STEEL (\Steel)`, `XS_CONCRETE (\Concrete)`, `XS_ENGINEERING (\Engineering)` and `XS_PRECAST (\Precast)` each point to the folders that contain the settings specific to that role. An example for steel role option in the `env_<environment>.ini` file could be as follows:

```
set XS_STEEL=%XSDATADIR%\environments\Steel\master_drawings\;%XSDATADIR%\environments\Steel\model_filters\;%XSDATADIR%\environments\Steel\model_settings\
```

To specify several system folders in `XS_SYSTEM`, enter the options pointing to the role options and separate them by semicolons.

Example

```
set XS_SYSTEM=%XS_STEEL%;%XS_ENGINEERING%;%XS_CONTRACTOR%;%XS_GENERAL%;%XSDATADIR%\environments\common\system\
```

Tekla Structures searches the folders from right to left. If files with identical names exist in several folders, the one that is read last will be used. In the example above, the files found from `XS_STEEL` will be used instead of the files with identical names in `common\system\` or in any other folder mentioned before the last folder.

This is a system-specific advanced option and cannot be changed.

19.99 XS_SYSTEM_INTERNAL

Category: File locations

WARNING Do not change the value of this advanced option.

This advanced option is only meant for administrators.

This advanced option defines the location of the read-only Tekla Structures system folder that contains files that are used internally by Tekla Structures. The system internal folder contains standard, data (.dat), and property files. This folder is always read by default.

If you have created your own custom standard files or do not want to use the system internal files, you can optionally disable the use of the system internal folder. Add `XS_DISABLE_SYSTEM_INTERNAL=true` to your environment .ini file (`env_<environment_name>.ini`).

NOTE Disabling the use of the system internal folder might remove paths to some important configuration files, which might prevent some components from working as intended.

See also

[XS_SYSTEM \(page 451\)](#)

20 Advanced options - T

20.1 TEMPLATE_FONT_CONVERSION_FILE

Category: Templates and symbols

Points to the location of the Tekla Structures system font (Template Editor font) conversion file `template_fonts.cnv`. By default the path is `%DXK_FONTPATH%\template_fonts.cnv` meaning, for example, `C:\ProgramData\Trimble\Tekla Structures\<>version>\environments\common\fonts\template_fonts.cnv`. This file is used for mapping Tekla Structures system fonts (fixfont, romsim, romsim8, romco) to Windows fonts in DWG/DXF export.

The syntax: `<Template Editor font>= windows font [* width correction factor]`

For example: `romco = Times New Roman * 0.5`

There is another conversion file, `dxg_fonts.cnv`, that converts the True Type fonts to SHX fonts.

This advanced option is system specific and is read from environment files. Generally, there is no need to modify system-specific settings. Do not modify them if you are not an administrator.

20.2 XS_TEMPLATE_DIRECTORY

Category: File locations

Points to the folders containing template (*.tpl) and report (*.rpt) files.

This advanced option is model specific and the setting is saved in the options database.

You can define several folder paths. Use a semicolon to separate the folder paths.

Templates are searched in several folders in a certain search order.

20.3 XS_TEMPLATE_DIRECTORY_SYSTEM

Category

This advanced option must be set in an initialization (.ini) file.

This advanced option is system specific and is read from environment files. Generally, there is no need to modify system-specific settings. Do not modify them if you are not an administrator.

This advanced option is used in `env_<environment_name>.ini` environment initialization files to define the location of environment-specific templates (.tpl) and reports (.rpt). You can use semicolon-separated lists of folder paths.

Other users than administrators can define local folders using the advanced options `XS_FIRM`, `XS_PROJECT` and `XS_TEMPLATE_DIRECTORY`.

Example

```
set XS_TEMPLATE_DIRECTORY_SYSTEM=%XSDATADIR%\environments\uk
\general\template\
```

See also

[XS_TEMPLATE_DIRECTORY](#) (page 453)

[XS_FIRM](#) (page 238)

[XS_PROJECT](#) (page 349)

20.4 XS_TEMPLATE_MARK_SUB_DIRECTORY

Category: File locations

Use this advanced option to change the name of the subfolder where Tekla Structures searches for the templates that you use in marks. When you are adding a template in a mark, the available templates are displayed in the **Mark content - template** dialog box. You cannot define several folders by using semicolon-separated lists of folder paths.

By default, `mark` is the value for this advanced option. You can create another folder with another name and save your mark templates there, and enter the name of that folder as the value for this advanced option.

This advanced option is model specific and the setting is saved in the options database.

Example

Example of using another folder:

```
XS_TEMPLATE_MARK_SUB_DIRECTORY=my_mark_tpl
```

The mark templates are in this example case searched from the following folders in the following order:

```
%XS_TEMPLATE_DIRECTORY%\my_mark_tpl
```

```
ModelDir\my_mark_tpl
```

```
%XS_PROJECT%\my_mark_tpl
```

```
%XS_FIRM%\my_mark_tpl
```

```
%XS_TEMPLATE_DIRECTORY_SYSTEM%\my_mark_tpl
```

```
%XS_SYSTEM%\my_mark_tpl
```

20.5 XS_TEXT_ORIENTATION_EPSILON

Category: Drawing properties

Use to define the point where dimension mark text that is positioned almost vertically is turned so that it is faced the other way around.

The default is `0.1`, which is 5.72958 degrees. For example, if you want the text to change (flip) at 100 degrees (or 10 off 90), you need to set this advanced option to `.175`.

This advanced option is model specific and the setting is saved in the options database.

Example

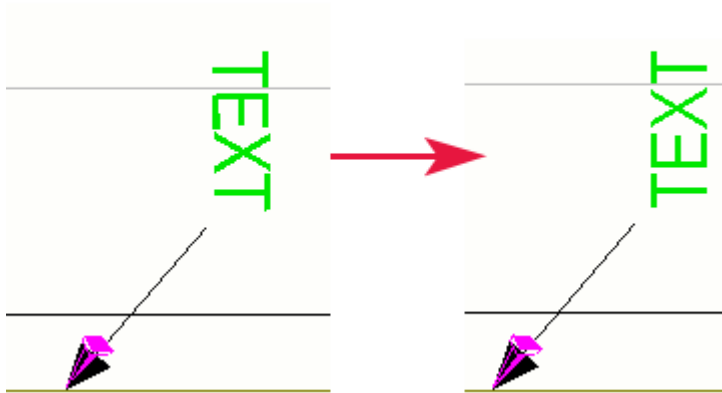

20.6 XS_THICKNESS_PARAMETER_IS_CROSS_SECTION_THICKNESS

Category

Profiles

Use to define the method to measure the thickness of parts (flanges, plates, walls and so on). When set to `FALSE`, the thickness parameter of the profile defines the actual thickness. When set to `TRUE`, the thickness parameter defines the cross section thickness (which is not same as the actual thickness if the part is sloped).

The default value is `FALSE`. We recommend that you use this value.

The change applies to the following profile types:

- SPD
- EPD
- I
- RHS
- PD
- P

20.7 XS_TPLED_INI

Category: File locations

Defines the location of the `tpled.ini` file. The `tpled.ini` file controls environment-specific template settings.

This is a system-specific advanced option.

Example

```
..\ProgramData\Trimble\Tekla Structures\<version>\  
\environments\default\template\settings\  

```

20.8 XS_TRY_TO_KEEP_LOCATION_IN_FREEPLACING

Category

Drawing Properties

Use to fine-tune the functionality of the **Arrange Drawing Objects** command in drawings.

This advanced option is set to `TRUE` by default, meaning that the **Arrange Drawing Objects** command tries to find a new location for the selected object as close to the current location as possible. If the current location is free, the object is not moved at all.

When this advanced option is set to `FALSE`, the **Arrange Drawing Objects** command works the same way as **Ignore Current Locations**.

This advanced option is model specific and the setting is saved in the options database.

20.9 XS_TUBE_UNWRAP_LIMIT_THICKNESS

Category

Drawing Properties

Use this advanced option to define how Tekla Structures draws tubes.

Set to a decimal value. Tekla Structures individually draws the inner and outer surfaces of tubes that are thicker than this value.

This advanced option is model specific and the setting is saved in the options database.

NOTE If the advanced option `XS_TUBE_UNWRAP_WITH_CUT_HOLES` is set to `TRUE`, this advanced option has no effect.

See also

[XS_TUBE_UNWRAP_WITH_CUT_HOLES \(page 459\)](#)

20.10 XS_TUBE_UNWRAP_PAPER_THICKNESS

Category

Drawing Properties

This advanced option lengthens unfolded tubes by the following multiplication factor:

factor = $1.0 + 2 * XS_TUBE_UNWRAP_PAPER_THICKNESS / diameter$

The default value is 0.0.

NOTE If the advanced option `XS_TUBE_UNWRAP_WITH_CUT_HOLES` is set to `TRUE`, this advanced option has no effect.

This advanced option is model specific and the setting is saved in the options database.

Example

Tube d=219

When you set the advanced option to 0, the unwrapped length of the tube ($1.0 * \pi * diameter$) = 688.

When the advanced option is set to 10, the length of the unfolded tube = factor * diameter * π = $(1.0 + 2 * 10 / 219) * 219 * 3.14 = 751$

See also

[XS_TUBE_UNWRAP_WITH_CUT_HOLES \(page 459\)](#)

20.11 XS_TUBE_UNWRAP_USE_PLATE_PROFILE_TYPE_IN_NC

Category

CNC

To use the plate profile type B in the NC file header data for unwrapped round tubes, set this advanced option to `TRUE`. To use RO for round tubes, set it to `FALSE`. The default value is `TRUE`.

This advanced option only works for straight tubes, not for polybeam tubes.

This advanced option is model specific and the setting is saved in the options database.

WARNING Use this advanced option only when you have set the advanced option `XS_TUBE_UNWRAP_WITH_CUT_HOLES` to `TRUE`.

See also

[XS_TUBE_UNWRAP_WITH_CUT_HOLES](#) (page 459)

20.12 XS_TUBE_UNWRAP_WITH_CUT_HOLES

Category

Drawing Properties

Set to `TRUE` to include cut holes in workshop drawings or NC files of unwrapped CHS (circular hollow section) profiles.

This advanced option is set to `TRUE` by default. If you set it to `FALSE`, then the previously existing unwrapping method is applied.

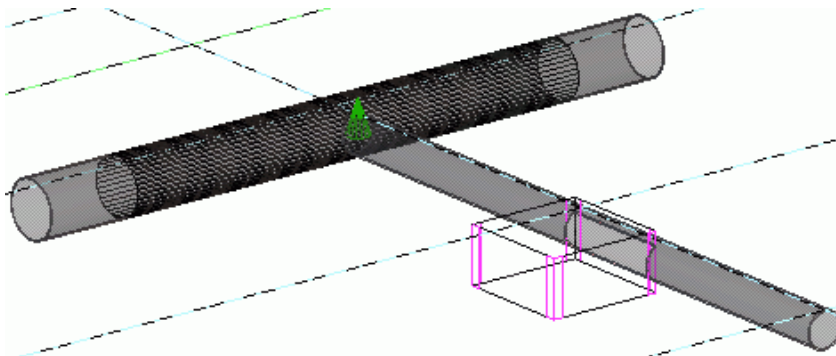

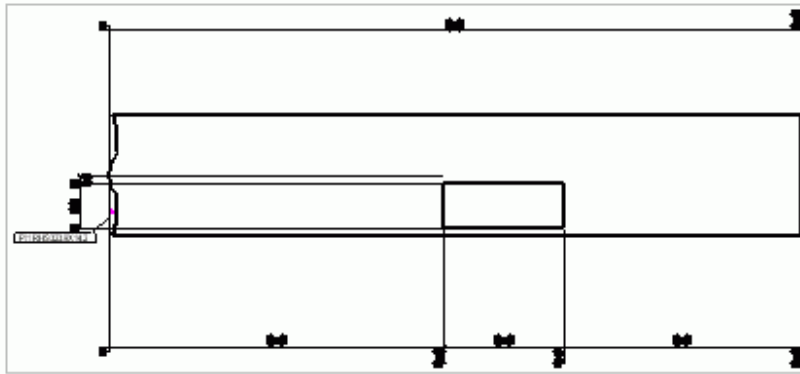

This advanced option is model specific and the setting is saved in the options database.

NOTE If you set this advanced option to `TRUE`, the advanced options `XS_TUBE_UNWRAP_LIMIT_THICKNESS` and `XS_TUBE_UNWRAP_PAPER_THICKNESS` have no effect.

Note also that using this advanced option does not affect conical tube profiles.

See also

[XS_TUBE_UNWRAP_LIMIT_THICKNESS \(page 457\)](#)

[XS_TUBE_UNWRAP_PAPER_THICKNESS \(page 458\)](#)

[XS_TUBE_UNWRAP_USE_PLATE_PROFILE_TYPE_IN_NC \(page 458\)](#)

21 Advanced options - U

21.1 XS_UEL_IMPORT_FOLDER

This advanced option must be set in an initialization (.ini) file. It is system-specific.

You can collect all the `.uel` files exported from your custom components and sketched profiles in folders, and then automatically import them to new models. Use this advanced option to point to the folders which contain the `.uel` files. Note that you must still manually export the desired custom components and sketched profiles to these folders.

You can point to several folders if you separate the folders with a semicolon. For example:

```
set XS_UEL_IMPORT_FOLDER=%XSDATADIR%\environments\default
\components_sketches\;%XSDATADIR%\environments\common\components_sketches
\concrete\;%XSDATADIR%\environments\common\components_sketches\steel
\;%XSDATADIR%\environments\common\components_sketches\
```

When this advanced option is set (preferably in the `user.ini` file), and you create a new model, Tekla Structures automatically imports the `.uel` files to the model.

NOTE To take the custom components and related sketched profiles in use in existing models, import the `.uel` files through the **Applications & components** catalog. If the `.uel` files only contain sketched profiles, import them through the profile catalog.

21.2 XS_UNDERLINE_AFTER_POSITION_NUMBER_IN_HARDSTAMP

Category

CNC

Set the advanced option to `TRUE` to have an underscore (`_`) after the part position (without an assembly position) in a hardstamp.

The default value is `FALSE`.

This advanced option is model specific and the setting is saved in the options database.

21.3 XS_UNFOLDING_ANGLE_DIM_FORMAT

Category

Dimensioning: Unfolding

Use to define the format of angle text by entering an integer 0 - 7. The default value is 1. Enter one of the following values:

- 0 = ###
- 1 = ###[.]#
- 2 = ###.#
- 3 = ###[.##]
- 4 = ###.##
- 5 = ###[.###]
- 6 = ###.###
- 7 = ### #/#

This advanced option is model specific and the setting is saved in the options database.

21.4 XS_UNFOLDING_DONT_USE_NEUTRAL_AXIS_FOR_RADIUS

Category

Dimensioning: Unfolding

Set this advanced option to `FALSE` to use the neutral axis of the part to calculate the bending radius in unfolded views. Set this advanced option to `TRUE` to calculate the bending radius from the inner surface of the part. The default value is `TRUE`. This advanced option only affects curved polybeams.

This advanced option is model specific and the setting is saved in the options database.

Note that this advanced option does not work if [XS_USE_OLD_POLYBEAM_LENGTH_CALCULATION \(page 485\)](#) is set to `TRUE`.

NOTE The settings in the `unfold_corner_ratios.inp` override this advanced option.

21.5 XS_UNFOLDING_ANGLE_DIM_PRECISION

Category

Dimensioning: unfolding

Use to define the precision of angle text. Enter an integer 1 - 10. The default value is 10. Enter one of the following values:

- 1 = 0.00
- 2 = 0.50
- 3 = 0.33
- 4 = 0.25
- 5 = 1/8
- 6 = 1/16
- 7 = 1/32
- 8 = 1/10
- 9 = 1/100
- 10 = 1/1000

Values 1 - 4 are intended for defining precision with rounding. For example, with precision 0.33 the actual dimension 50.40 is shown as 50.33. Values 5 - 7 are used for imperial units only. Values 8 - 10 are used for defining precision without rounding.

This advanced option is model specific and the setting is saved in the options database.

21.6 XS_UNFOLDING_PLANE_EPSILON

Category

Dimensioning: Unfolding

Use to specify the limit for checking if all section points are on the same plane. If the points are on the same plane, the part can be unfolded. Enter the value in millimeters. The default value is 0.01 mm.

This advanced option is model specific and the setting is saved in the options database.

21.7 XS_UNIQUE_NUMBERS

Category

Numbering

Set this advanced option to `TRUE` to have Tekla Structures create unique position numbers for all parts when numbering, even if they are equal. The default value is `FALSE`.

See also

[XS_UNIQUE_ASSEMBLY_NUMBERS](#) (page 464)

21.8 XS_UNIQUE_ASSEMBLY_NUMBERS

Category

Numbering

Set to `TRUE` if you want Tekla Structures to create unique position numbers for all assemblies when numbering, even if they are identical.

The default value is `FALSE`.

Parts are still numbered the same way as before.

This advanced option is model specific and the setting is saved in the options database.

See also

[XS_UNIQUE_NUMBERS](#) (page 464)

21.9 XS_UPDATE_MARK_PLACING_IN_DRAWING

Category

Marking: Parts

Updates the position of updated marks in specific drawing types. Use the letters in the following table to specify the drawing types.

| Letter | Drawing type |
|--------|------------------------------|
| W | Single-part drawings |
| A | Assembly drawings |
| M | Multidrawings |
| G | General arrangement drawings |
| C | Cast unit drawings |

The default value is AMW, which means that the mark position is updated in assembly drawings, multidrawings and single-part drawings.

This advanced option is model specific and the setting is saved in the options database.

Example

To update the position of updated part marks in single-part, assembly, multi-, and general arrangement drawings:

```
XS_UPDATE_MARK_PLACING_IN_DRAWING=WAMG
```

21.10 XS_UPDATE_MARKS_IN_FROZEN_DRAWINGS

Category

Marking: General

Set this advanced option to `TRUE` to automatically update marks in frozen drawings and create new marks if new parts have been added. If you set it to `FALSE`, Tekla Structures only updates parts and bolts. The default value is `TRUE`.

This advanced option is model specific and the setting is saved in the options database.

21.11 XS_UPLOAD_SHARED_MODEL_TO_CONNECT

Category

Multi-user

Use this advanced option to select when a Tekla Structures model that has been shared with Tekla Model Sharing is uploaded to a folder in the attached Trimble Connect folder. The shared model will be uploaded to this folder as a read-only `.tekla` reference model that you can use in Tekla Structures and Trimble Connect.

The options are:

- `BASELINE` (default) = The shared model is automatically uploaded to the set Trimble Connect project folder each time a user creates a new baseline.
- `WRITEOUT` = The shared model is automatically uploaded to the set Trimble Connect project folder after each successful write out.
- `<NO VALUE>` = The shared model is never uploaded to the set Trimble Connect project folder.

Note that the path to the Trimble Connect project folder is set with the [XS_CONNECT_UPLOAD_MODEL_FOLDER](#) (page 102) advanced option.

This advanced option is model specific and the setting is saved in the options database.

21.12 XS_UPSIDE_DOWN_TEXT_ALLOWED

Category: Concrete detailing

Set this advanced option to `TRUE` to have the text reading direction indicate the part installation direction. If there are similar asymmetric parts with different orientation, some part marks may be placed upside down. When you set the advanced option to `FALSE` (default), none of the part marks are created upside down, so the text reading direction does not indicate the installation direction. If you set this advanced option to

- `CONCRETE`, only concrete marks and texts are upside down
- `STEEL`, only steel marks and texts are upside down
- `TIMBER`, only timber marks and texts are upside down

You can also use combinations of values separated by a comma, for example, `CONCRETE, STEEL`.

NOTE You need to use uppercase in the value, because writing 'true' only affects free texts, whereas writing 'TRUE' affects both free texts and part marks.

Example of the mark orientation when the advanced option is set to TRUE.

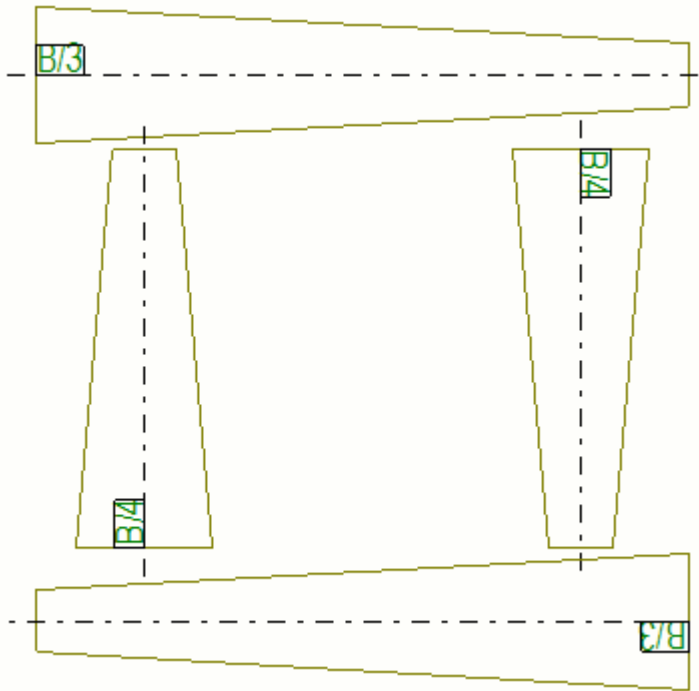

This advanced option is role specific. When the type **SYSTEM(ROLE)** is in use, the default value is used. When the type **MODEL(ROLE)** or **DRAWING(ROLE)** is in use, you can change the value, which is then the same for all users in the current model.

21.13 XS_USABSOLUTE_TO_RELATIVE_LIMIT

Category

Dimensioning: General

Use to affect the distance within which the first and last US Absolute dimension lines appear as relative. By default, this advanced option is not set to any value.

Example

`XS_USABSOLUTE_TO_RELATIVE_LIMIT=1000`

In this example, Tekla Structures will change first and last dimension lines shorter than 1000 mm to Relative dimensions. Dimension lines greater or equal to 1000 mm will remain US Absolute dimensions.

This advanced option is model specific and the setting is saved in the options database.

21.14 XS_USABSOLUTE2_TO_RELATIVE_LENGTH_FACTOR

Category: Dimensioning - general

Tekla Structures multiplies the space required by the **US Absolute 2** or **Absolute plus short relatives** dimension text by the value you type. If the result is larger than the actual dimension, Tekla Structures changes the dimension type to relative. The default value is 1.5.

This advanced option is model specific and the setting is saved in the options database.

21.15 XS_USE_ANTI_ALIASING_IN_DX

Category: Model views

Use this advanced option to control whether antialiasing is used in the DirectX rendered model views. Antialiasing makes the edge lines smoother but with low resolution screens it can make the lines look thicker.

By default, this advanced option is set to `TRUE`.

21.16 XS_USE_ASSEMBLY_EXTREMA_IN_MARK_PLACING

Category: Marking - general

Use this advanced option to place part marks on top of the assembly instead of on top of the main part.

First create a drawing view filter that fetches a specific part or group of parts and give it a unique name, and then enter the name of the drawing view filter as a value for the advanced option. Note that filter names are case sensitive in some systems.

The example below uses part names as the filtering criteria.

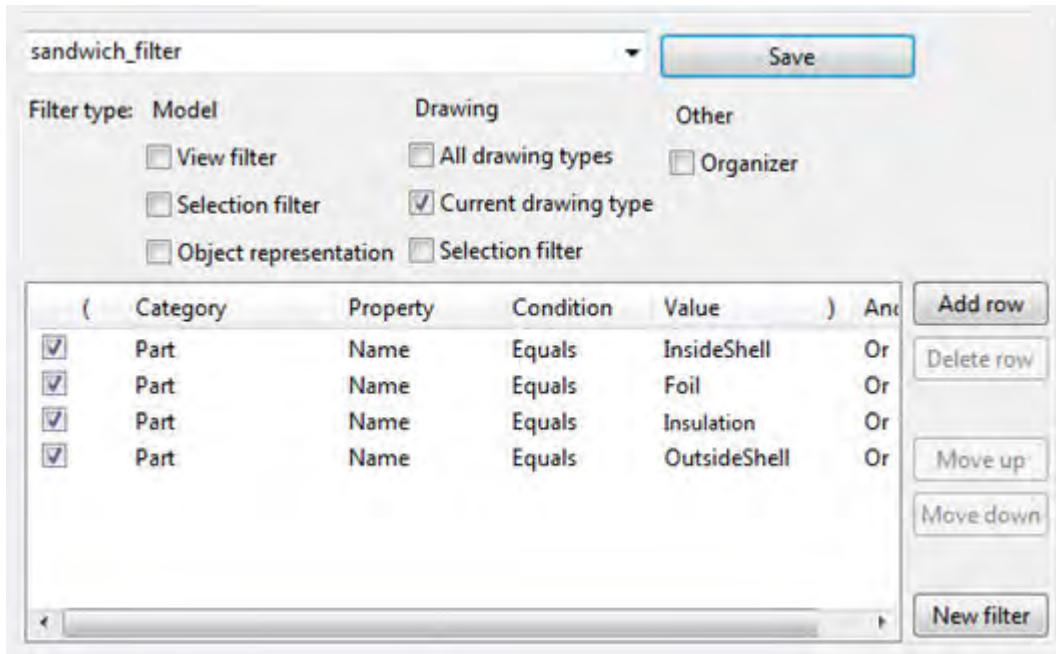

When you (re)create the drawing, the mark place changes from this:

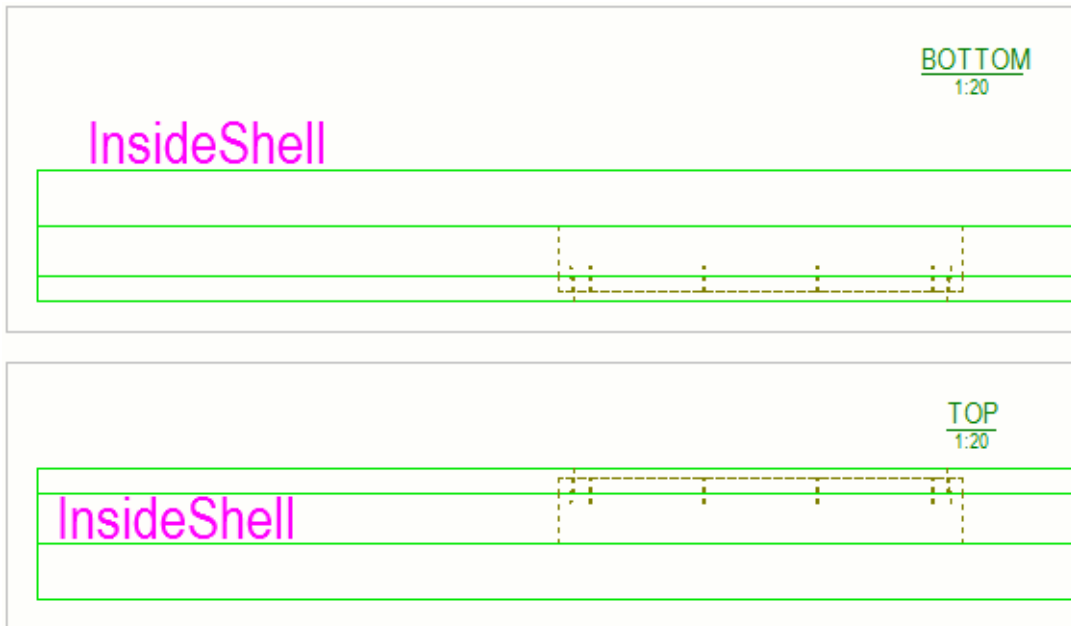

To this:

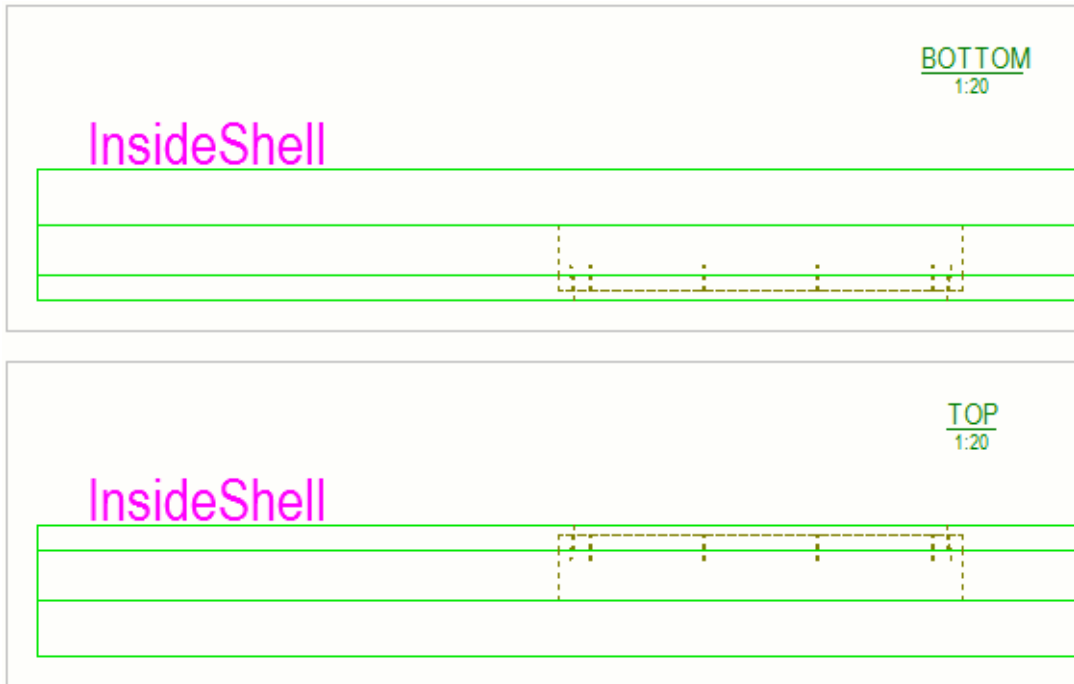

The supported mark placing types are shown below.

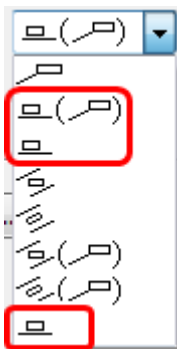

21.17 XS_USE_ASSEMBLY_NUMBER_FOR

Category: Numbering

Use this advanced option if you want the assembly/cast unit number to be also the main part number for the corresponding assembly/cast unit. Use one of the following options:

- Leave this option blank for each part in the assembly to get a part number, regardless of whether the assembly contains only one main part or several parts. Click the link to see an example of [one part only](#) or of [multiple parts](#).
- Set to `MAIN_PART` to always assign the assembly or cast unit number to the main part of an assembly or cast unit. All other parts, if any, will use part

number. Click the link to see an example of [one part only](#) or of [multiple parts](#).

- Set to `LOOSE_PART` to assign the assembly or cast unit number to the main part of an assembly or cast unit that has no other parts. If the assembly or cast unit has several parts, the main part will receive a part number. Click the link to see an example of [one part only](#) or of [multiple parts](#).

The assembly prefix replaces the part prefix.

NOTE Do not use the same prefix for parts and assemblies.

This advanced option is role specific. When the type **SYSTEM(ROLE)** is in use, the default value is used. When the type **MODEL(ROLE)** or **DRAWING(ROLE)** is in use, you can change the value, which is then the same for all users in the current model.

21.18 XS_USE_BOLT_DISTANCE_IN_NOTCH_CALCULATIONS

This advanced option must be set in an initialization (.ini) file.

Set this advanced option to `TRUE` to use automatic notch height calculation according to bolt distance. This affects connections 129 and 184.

21.19 XS_USE_COLOR_DRAWINGS

Category: Drawing views

Changes the default color mode in drawings when Tekla Structures is started.

- If you set this advanced option to `FALSE` or leave the value out, drawings are black and white.
- To have grayscale drawings, set it to `GRAY`.
- To use colors in drawings, set it to any other value, for example, `COLOR`, `TRUE`, or `1`. `TRUE` is the default value.

This advanced option is user specific and the setting is saved in `options.bin` under the user folder, for example, in `C:\Users\\AppData\Local\Trimble\Tekla Structures\\UserSettings`. Restart Tekla Structures to activate the new value.

21.20 XS_USE_CONVEX_PROTECT_AREA

This advanced option must be set in an initialization (.ini) file.

Set this advanced option to `TRUE` to automatically calculate the protection area more accurately along the faces of parts, so that part marks can be placed inside the profile also for curved hollow sections. To protect the area of the object covers, enter `FALSE`. The default value is `TRUE`.

This advanced option is model specific and the setting is saved in the options database.

21.21 XS_USE_CROSS_FOR_OPENING_SYMBOL



Category



Drawing Properties

Use `XS_USE_CROSS_FOR_OPENING_SYMBOL` to select how the openings/recesses are shown and the symbols to be used.

The default value is `TRUE`, which means that a cross is used as the opening/recess symbol.

This advanced option is model specific and the setting is saved in the options database.

| Value | Description |
|---|--|
| <code>TRUE</code> This is the default. | <p>Crosses are used as symbols for openings as follows:</p>  <p>If the recess is on the front face of the part, recess symbol and bounding lines are shown as unbroken lines as follows:</p>  <p>If the recess is on the back face of the part, recess symbol and bounding lines are shown as dashed lines as follows:</p>  |

| Value | Description |
|-------|--|
| FALSE | <p>Shadows are used as symbols for openings as follows:</p>  <p>If the recess is on the front face of the part, there is no recess symbol, and bounding lines are shown as unbroken lines as follows:</p>  <p>If the recess is on the back face of the part, there is no recess symbol, and bounding lines are shown as dashed lines as follows:</p>  |

21.22 XS_USE_DRAWING_NAME_AS_PLOT_FILE_NAME

Category

This advanced option must be set in an initialization (.ini) file.

Set this advanced option to `TRUE` to prevent Tekla Structures from converting the dot in the drawing name to an underscore in the plot file name when printing, for example B.1 to B_1. The default value is `FALSE`.

21.23 XS_USE_DYNAMIC_ROW_WIDTH_IN_TEMPLATES

Category

This advanced option is available only in initialization files.

This advanced option does not work in report templates.

Set this advanced option to `TRUE` to fit the template row width dynamically according to the content, for example, drawing frames according to the different drawing sizes. The content must always be located on the right. If you

set this advanced option to `FALSE`, automating fitting of the templates rows is not in use.

The default value is `FALSE`.

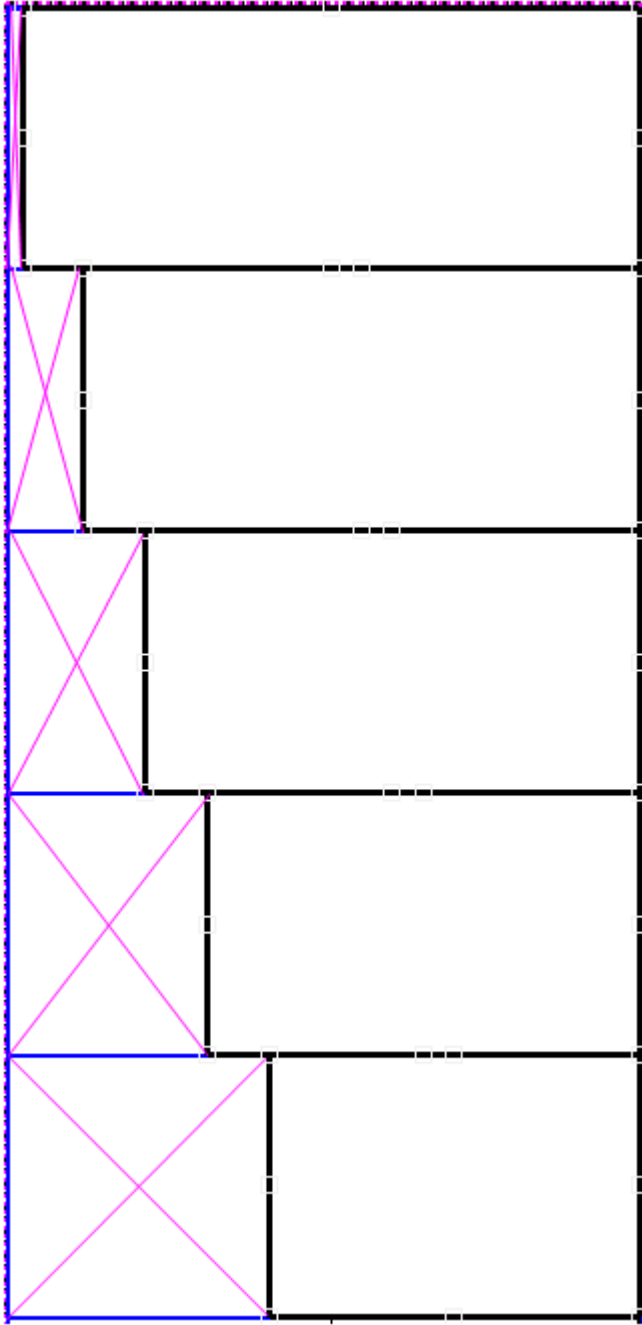

NOTE This functionality is not available in drawing part mark templates.

21.24 XS_USE_DRAWING_NAME_AS_PLOT_TITLE

Category

Printing

Set this advanced option to `TRUE` when you want to use the drawing name as the print title, for example, when printing to a `.pdf` file or to a Windows printer. To use the general Tekla Structures print title, such as "Tekla Structures drawing - A [T.100]", set it to `FALSE`. The default value is `TRUE`.

As a result, the Windows printer dialog box, and the pdf file name will contain the drawing print file name you define with the advanced options listed below.

This advanced option is user specific and the setting is saved in `options.bin` under the user folder, for example, in `C:\Users\\AppData\Local\Trimble\Tekla Structures\\UserSettings`. Restart Tekla Structures to activate the new value.

See also

[XS_DRAWING_PLOT_FILE_NAME_A](#) (page 184)

[XS_DRAWING_PLOT_FILE_NAME_C](#) (page 190)

[XS_DRAWING_PLOT_FILE_NAME_W](#) (page 186)

[XS_DRAWING_PLOT_FILE_NAME_G](#) (page 187)

[XS_DRAWING_PLOT_FILE_NAME_M](#) (page 189)

21.25 XS_USE_EIGHT_COLORS_IN_MODELING_VIEWS

Set this advanced option in the `user.ini` file located in `..\Users\\AppData\Local\Trimble\Tekla Structures\\UserSettings`.

Set to `TRUE` to disable additional colors in model views. The default value is `FALSE`.

21.26 XS_USE_EXACT_SOLID_FOR_CLASH_CHECK

Category

Speed and Accuracy

If you set this advanced option to `FALSE` (default), normal solid accuracy is used in clash checking. If you need to use high solid accuracy in clash checking, set this advanced option to `TRUE`. This advanced option is model specific.

WARNING Using high accuracy, that is, setting this advanced option to `TRUE`, slows down the clash checking process, and there is a higher risk of solid errors.

21.27 XS_USE_EXISTING_SINGLE_PART_DRAWINGS_IN_ASSEMBLY_DRAWINGS

Category

Single Part View in Assembly Drawing

You can specify whether to create new views or to use views from existing single part drawings in assembly drawings. When this advanced option is set to `TRUE`, existing single part drawing views will be used in assembly drawings. When set to `FALSE`, or if there is no existing single part drawing for a given part, a new view will be created according to the **Single-part attributes** setting (**Assembly drawing properties** --> **Layout** --> **Other**). The default value is `FALSE`.

NOTE This setting only works with assembly drawings, not with multidrawings

This advanced option is model specific and the setting is saved in the options database.

21.28 XS_USE_EXISTING_SINGLE_PART_DRAWINGS_SCALE

Category: Single Part View in Assembly Drawing

If you do not want to maintain the scale of the existing single part drawing included in an assembly drawing, set the advanced option `XS_USE_EXISTING_SINGLE_PART_DRAWINGS_SCALE` to `FALSE`. When you do this, the scale of the included single part drawing will follow the scale of the assembly drawing, or advanced option `XS_SINGLE_SCALE` (page 429) if it is set.

Tekla Structures maintains the original scale in a single part drawing in an assembly drawing when you set the layout to include single part drawings, and set the option

[XS_USE_EXISTING_SINGLE_PART_DRAWINGS_IN_ASSEMBLY_DRAWINGS](#) (page 476) is set to `TRUE`.

This advanced option is model specific and the setting is saved in the options database.

21.29 XS_USE_FLAT_DESIGNATION

Category: Plate work

Set this advanced option to `TRUE` to use flat bar designation, which means that Tekla Structures shows plates as the equivalent flat bars for manufacturing. The default value is `FALSE`.

Indicate the prefix you want to use for flat bars using the advanced option [XS_FLAT_PREFIX](#) (page 239).

This advanced option is model specific and the setting is saved in the options database.

21.30 XS_USE_INTEGRATED_BUILDING_HIERARCHIES

Category: Modeling properties

To define building levels and hierarchies in the **Building hierarchy** dialog box, set this advanced option to `TRUE`.

The default value is `FALSE`.

This advanced option is model specific and the setting is saved in the options database.

Reopen the model after changing the value to activate the new setting.

21.31 XS_USE_LINECLIP

Category: Printing

Set this advanced option to `TRUE` to clip continuous lines at objects in drawing printouts (paper or `.pdf`). Set to `FALSE` to display continuous lines, for example, to run the line through text or drawing marks. The default value is `TRUE`.

`XS_USE_LINECLIP` is set to `TRUE`:

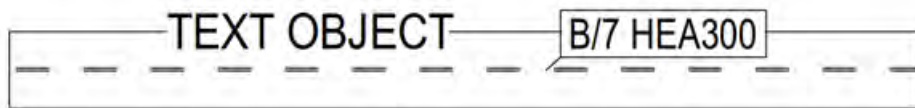

`XS_USE_LINECLIP` is set to `FALSE`:

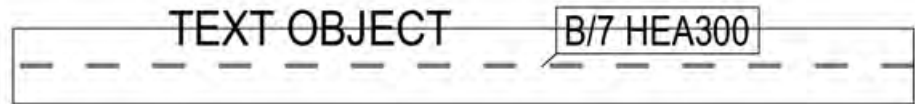

This is how the line clipping is displayed in drawings currently:

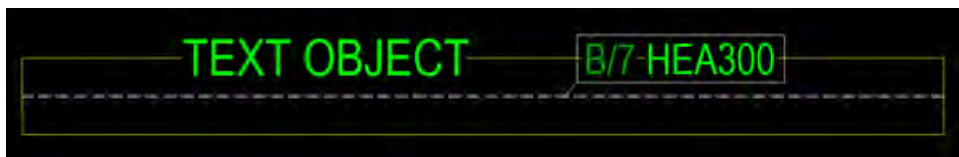

This is how it is printed:



Note that this setting only affects drawings printed using the old printing functionality (`XS_USE_OLD_PLOT_DIALOG=TRUE`), and it does not completely match what you see in drawings in Tekla Structures. If

`XS_USE_OLD_PLOT_DIALOG` is set to `FALSE` (default), then `XS_USE_LINECLIP` has currently no effect, and the lines are clipped in the same way in drawings and in printouts. With the current printing feature you can use a background mask for texts and marks as a substitute for this advanced option. You can set the **Background mask** option in text and mark properties.

This advanced option is role specific. When the type **SYSTEM(ROLE)** is in use, the default value is used. When the type **MODEL(ROLE)** or **DRAWING(ROLE)** is in use, you can change the value, which is then the same for all users in the current model.

21.32 `XS_USE_LONG_POINTS_IN_DIMENSIONING`

Category

Dimensioning: Parts

Sometimes there may be a need to dimension the parts in assembly or single-part drawings so that copes or notches are not taken into account, for example, to estimate the space needed for transportation.

If you set this advanced option to `TRUE`, the overall dimensions are calculated to long points. If you set it to `FALSE`, the overall dimensions are calculated to cope points. `FALSE` is the default.

This advanced option is role specific. When the type **SYSTEM(ROLE)** is in use, the default value is used. When the type **MODEL(ROLE)** or **DRAWING(ROLE)** is in use, you can change the value, which is then the same for all users in the current model.

Example

In the example below, the upper dimension (the red one) shows the result when this advanced option is set to `TRUE`, and the lower one when it is set to `FALSE` (the green one).

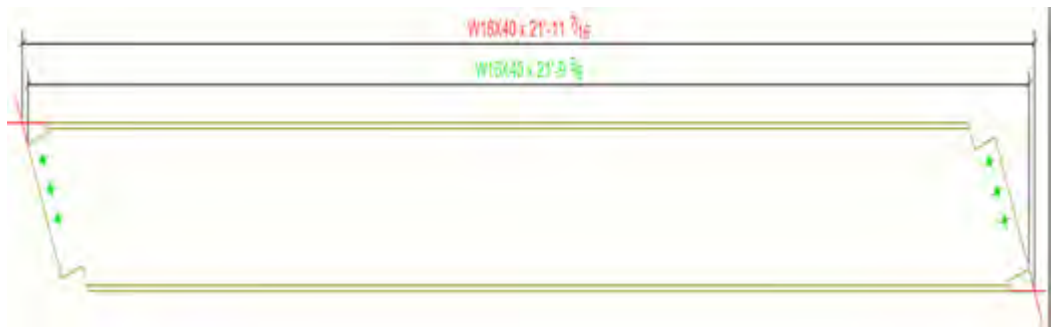

WARNING Using this advanced option will not affect the length of the part in the BOM, reports, or CNC.

21.33 XS_USE_MODEL_PREFIX_IN_MULTI_NUMBERS_FOR

Category: Numbering

Use to allow the prefixes used in part and assembly numbering to be used in multidrawing numbers. Enter any of the following options: `NONE`, `ASSEMBLIES`, `PARTS`, and `ASSEMBLIES_AND_PARTS`. The default value is `ASSEMBLIES_AND_PARTS`.

This advanced option is model specific and the setting is saved in the options database.

Example

If you set this advanced option to `PARTS`, the multinumbers for parts appear as 101Pa.

See also

[XS_USE_MULTI_NUMBERING_FOR](#) (page 480)

[XS_MODEL_PREFIX_INFLUENCES_MULTI_NUMBERING_FOR](#) (page 308)

21.34 XS_USE_MULTI_NUMBERING_FOR

Category: Numbering

Use to define if multinumbering affects assemblies, parts, or both. Part and assembly numbering must be based on drawing numbers to use multinumbering.

The options are:

- **NONE:** No assemblies or parts will get multi-numbered, even if linked to multidrawings.
- **ASSEMBLIES:** Assemblies will get multinumbered, but parts will not. This is the default US Imperial Steel setting.
- **PARTS:** Only parts will get multinumbered. Common if you are creating drawings for assemblies one per sheet, and handling parts on large collection sheets grouped by plates, or angles, for example.
- **ASSEMBLIES_AND_PARTS:** Both assemblies and parts will get multinumbering, but how is determined by workflow and other settings.

The default value is `ASSEMBLIES_AND_PARTS`.

WARNING Do not change the value during a project.

This advanced option is model specific and the setting is saved in the options database.

See also

[XS_MULTI_NUMBERING_INCLUDE_ASSEMBLY_PARTS](#) (page 310)

[XS_USE_MULTI_NUMBERING_WHEN_COPYING_DRAWING_VIEWS](#) (page 481)

[XS_USE_NUMERIC_MULTI_NUMBERS_FOR](#) (page 483)

[XS_MODEL_PREFIX_INFLUENCES_MULTI_NUMBERING_FOR](#) (page 308)

[XS_USE_MODEL_PREFIX_IN_MULTI_NUMBERS_FOR](#) (page 479)

[XS_SWITCH_MULTI_NUMBERS_FOR](#) (page 450)

[XS_PART_MULTI_NUMBER_FORMAT_STRING](#) (page 327)

[XS_ASSEMBLY_MULTI_NUMBER_FORMAT_STRING](#) (page 55)

[XS_CAST_UNIT_MULTI_NUMBER_FORMAT_STRING](#) (page 82)

[XS_VALID_CHARS_FOR_PART_MULTI_NUMBERS](#) (page 502)

[XS_VALID_CHARS_FOR_ASSEMBLY_MULTI_NUMBERS \(page 501\)](#)

[XS_MIN_NUMBER_OF_PART_MULTI_CHARACTERS \(page 305\)](#)

[XS_MIN_NUMBER_OF_ASSEMBLY_MULTI_CHARACTERS \(page 305\)](#)

21.35 XS_USE_MULTI_NUMBERING_WHEN_COPYING_DRAWING_VIEWS

Category: Numbering

Set this advanced option to `TRUE` to use multinumbers when copying drawing views. If you do not want to use multinumbers, set it to `FALSE`. The default value is `FALSE`.

This advanced option is user specific and the setting is saved in `options.bin` under the user folder, for example, in `C:\Users\\AppData\Local\Trimble\Tekla Structures\\UserSettings`. Restart Tekla Structures to activate the new value.

See also

[XS_USE_MULTI_NUMBERING_FOR \(page 480\)](#)

21.36 XS_USE_NEW_PLATE_DESIGNATION

Category

Plate Work

Use this advanced option to control if the width and length are switched in parts if the width is greater than the length. The options are:

- Option is not used: set value to blank or `FALSE`.
- Option is used only for steel parts: set value to `FOR_STEEL_PARTS_ONLY`.
- Option is used for all parts: set value to `TRUE`. This option is also used if value is set to anything else that does not match the other options above.

This advanced option is role specific. When the type **SYSTEM(ROLE)** is in use, the default value is used. When the type **MODEL(ROLE)** or **DRAWING(ROLE)** is in use, you can change the value, which is then the same for all users in the current model.

Example

A beam has the profile BL15*240 and the distance between beam endpoints is changed to 215 mm:

- If `XS_USE_NEW_PLATE_DESIGNATION` is used, the length of the beam is fixed at 240, and the beam profile changes to BL15*215.
- If `XS_USE_NEW_PLATE_DESIGNATION` is not used, the length of the beam is 215 and the profile remains BL15*240.

21.37 XS_USE_NEW_WELD_PLACING

Category: Welds

If you have set welds visible in the drawing, this advanced option affects in which drawing view (front, back, top, or bottom) Tekla Structures draws the welds.

- When the advanced option is set to `TRUE`, Tekla Structures draws welds in the view that has the best visibility to the **secondary part** (default).
- When the advanced option is set to `FALSE`, Tekla Structures selects the view according to the **main part**.

This advanced option is model specific and the setting is saved in the options database.

21.38 XS_USE_NEW_USNOTCH

Category

Components

Use to indicate whether to locate the horizontal cut of a notch above or below the flange of the main beam. The default value is `TRUE`. If you do not want to use the US style notch, set this advanced options to `FALSE`.

Used with the following notching options:

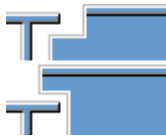

This advanced option is model specific and the setting is saved in the options database.

21.39 XS_USE_NUMBER_SELECTED_FOR_DRAWING_CREATION_AND_UPDATE

Category: Numbering

If the numbering is not up to date when you create a drawing, Tekla Structures asks you to number the model.

Set this advanced option to `TRUE` to number only the assemblies and parts that have the same numbering series as the selected part (or the main part of the selected drawing).

When set to `TRUE`, this advanced option does the same as if you clicked **Drawings & reports --> Number series of selected objects**. `TRUE` is the default value.

If you set this advanced option to `FALSE`, Tekla Structures numbers the whole model, which is the same as clicking **Drawings & reports --> Numbering --> Number modified objects**.

This advanced option is model specific and the setting is saved in the options database.

21.40 XS_USE_NUMERIC_MULTI_NUMBERS_FOR

Category: Numbering

Use to define which objects have numeric multi-numbers. The options are:

- `ASSEMBLIES`
- `PARTS`
- `ASSEMBLIES_AND_PARTS`
- `NONE`

This advanced option is model specific and the setting is saved in the options database.

Example

If you set this advanced option to `PARTS`, Tekla Structures displays the part multinumber as e.g. 101/1, instead of 101/a.

See also

[XS_USE_MULTI_NUMBERING_FOR](#) (page 480)

21.41 XS_USE_OLD_DRAWING_CREATION_SETTINGS

This advanced option must be set in an initialization (.ini) file.

Set the advanced option `XS_USE_OLD_DRAWING_CREATION_SETTINGS` to `TRUE` to use old drawing functionality and old drawing view property dialog boxes and subdialog boxes. In this old approach, drawing object properties can be defined on both drawing and view level, not individually for each view, like in the new view-level approach. View-level dimensioning rules are not supported.

By default, this advanced option is not in use.

Where to change the value depends on your company or project size, and on which level you need to unify certain enterprise-level settings. You can set this advanced option to `TRUE` in the `options.ini` file under the current model folder, in company's own `company.ini` file, your company's own `role.ini` file, or the `options.ini` file in firm or project folders, for example.

Note that Trimble Solutions no longer maintains the old functionality and dialog boxes. In practice, this means that new features, like custom presentations or automatic view-level properties will not be available in the old dialog boxes.

21.42 XS_USE_OLD_DRAWING_EXPORT

This advanced option must be set in an initialization (.ini) file.

If you want to use the old DWG/DXF export, set the advanced option `XS_USE_OLD_DRAWING_EXPORT` to `TRUE` in an `.ini` file. This advanced option is by default set to `FALSE`.

21.43 XS_USE_OLD_DRAWING_LIST_DIALOG

Category: Drawing properties

Document manager is enabled by default instead of **Drawing list**. All commands and buttons that would have launched **Drawing list** in earlier Tekla Structures versions will from version 2018i onwards launch **Document manager**. If you want to enable the old **Drawing list** instead, set this advanced option to `TRUE`. If you do this, **Document manager** will be disabled.

This advanced option is user specific and the setting is saved in `options.bin` under the user folder, for example, in `C:\Users\<user>\AppData\Local\Trimble\Tekla Structures\<version>\UserSettings`.

21.44 XS_USE_OLD_PLOT_DIALOG

Category

Printing

Set this advanced option to `TRUE` to use **Printer Catalog** and Tekla Structures own printer instances in printing.

The default value is `FALSE`.

This advanced option is user specific and the setting is saved in `options.bin` under the user folder, for example, in `C:\Users\\AppData\Local\Trimble\Tekla Structures\\UserSettings`. Restart Tekla Structures to activate the new value.

21.45 XS_USE_OLD_POLYBEAM_LENGTH_CALCULATION

Category

Dimensioning: Unfolding

Set this advanced option to `TRUE` to calculate polybeam length using the legacy method where lengths of straight parts are added together, without taking the unfolding into account. If you set it to `FALSE` (default) and use the new method, the polybeam length is defined by unfolding the polybeam first and then calculating the length. This way of calculating gives a more accurate value for the polybeam length.

This advanced option is model specific and the setting is saved in the options database.

NOTE Using this advanced option is not recommended, because the length may not be reported correctly in all cases, especially for polybeams with curved chamfers.

NOTE When you switch on this advanced option, other ways to calculate polybeam length are not used by Tekla Structures, for example, `XS_CALCULATE_POLYBEAM_LENGTH_ALONG_REFERENCE_LINE`, `XS_DONT_USE_NEUTRAL_AXIS_FOR_RADIUS` or the `unfold` parameter settings in file `unfold_corner_ratios.inp`.

See also

[XS_CALCULATE_POLYBEAM_LENGTH_ALONG_REFERENCE_LINE](#) (page 79)

21.46 XS_USE_ONLY_INCHES_IN_SHEET_SIZES

Category

Imperial Units

Set this advanced option to `TRUE` to have sheet sizes in layouts and drawing lists in inches. To have the sheet sizes in feet and inches, set it to `FALSE` (default).

In order for this advanced option to work, set the advanced options `XS_IMPERIAL` and `XS_IMPERIAL_INPUT` to `TRUE`.

This advanced option is model specific and the setting is saved in the options database.

21.47 XS_USE_ONLY_INCHES_IN_WELD_LENGTH

Category

Imperial units

Set this advanced option to `TRUE` to only display inches in weld length symbols. If you do not want to do this, set this advanced option to `FALSE`. This advanced option only works when the imperial units are in use. The default value is `TRUE`.

When you only display inches means that instead of showing 1ft 2inch it shows 14inch, for example.

This advanced option is user specific and the setting is saved in `options.bin` under the user folder, for example, in `C:\Users\\AppData\Local\Trimble\Tekla Structures\\UserSettings`. Restart Tekla Structures to activate the new value.

21.48 XS_USE_ONLY_NOMINAL_REBAR_DIAMETER

Category

Concrete Detailing

Nominal diameter is the diameter used for calculating the cross section area of the reinforcing bar. Actual diameter takes into account the ribs, and tells the smallest hole diameter where the bar fits.

Values used for nominal and actual diameter are defined in `rebar_database.inp`, which is located in the environment folders in `\<environment>\profil`.

Set the advanced option to `TRUE` to use nominal diameter. To use the actual diameter set this advanced option to `FALSE`. The default value is `FALSE`.

When the advanced option is set to `FALSE`, and you open a model created earlier than Tekla Structures version 18, the center line of the reinforcing bars stays in place and the concrete cover is reduced. All bending dimensions of the reinforcing bar increase. To solve this problem, either set the advanced option to `TRUE` or modify the concrete covers of all reinforcing bars to the correct value.

When reinforcing bars are exported to Unitechnik, you can select to export either nominal or actual diameters. For other exports (for example, BVBS), the nominal diameter is always used in the exported definitions regardless of this advanced option.

WARNING Do not change this option during a project.

Changing the advanced option also changes the modeled reinforcing bars. This means that if the actual diameter will be used, the reinforcing bar looks thicker in the model. To accommodate for the thicker reinforcing bar, Tekla Structures will automatically change also concrete cover thickness. When you change the option, Tekla Structures changes the concrete cover values after next restart.

This advanced option is role specific. When the type **SYSTEM(ROLE)** is in use, the default value is used. When the type **MODEL(ROLE)** or **DRAWING(ROLE)** is in use, you can change the value, which is then the same for all users in the current model.

21.49 XS_USE_OPENING_SYMBOL_IN_BORDER_HOLES

Category

Drawing Properties

Use `XS_USE_OPENING_SYMBOL_IN_BORDER_HOLES` to select whether to use an opening symbol in openings located at part borders.

| Value | Description |
|-------|---|
| TRUE | Opening symbol is used in the openings located at the border of the part. The symbol used depends on the setting of the advanced option |

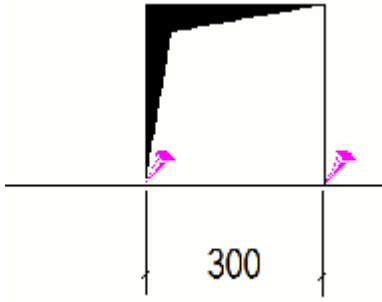
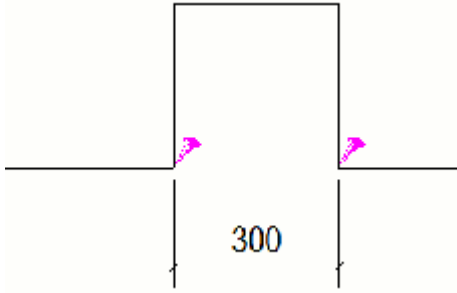
| Value | Description |
|-------------------------------|--|
| | XS_USE_CROSS_FOR_OPENING_SYMBOL  |
| FALSE This is the default. | No opening symbol is used for openings at the border of the part.  |

This advanced option is model specific and the setting is saved in the options database.

See also

[XS_USE_CROSS_FOR_OPENING_SYMBOL \(page 472\)](#)



21.50 XS_USE_OPENING_SYMBOL_IN_CORNER_HOLES

Category

Drawing Properties

Use XS_USE_OPENING_SYMBOL_IN_CORNER_HOLES to select whether to use the opening symbol in openings located in part corners.

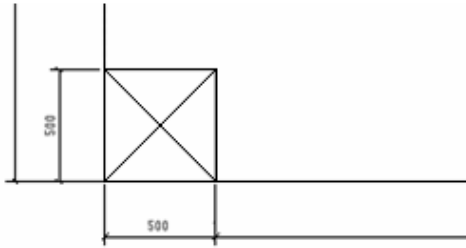
| Value | Description |
|-------|---|
| TRUE | Opening symbol is used in the openings located in the corner of |

| Value | Description |
|---------------------------------------|---|
| | <p>the part. The symbol used depends on the setting of the advanced option <code>XS_USE_CROSS_FOR_OPENING_SYMBOL</code>.</p>  |
| <p>FALSE This is the default.</p> | <p>No opening symbol is used for openings in the corner of the part.</p>  |

This advanced option is model specific and the setting is saved in the options database.

See also

[XS_USE_CROSS_FOR_OPENING_SYMBOL \(page 472\)](#)

21.51 XS_USE_PLATE_SIDE_POSITIONING

Category

Dimensioning: Parts

Set this advanced option to `TRUE` to make the position dimension of plates dependent on the position of the plates in the model. When a plate is positioned underneath the work plane, Tekla Structures will place the position dimension on the top face of the plate. The default value is `FALSE`.

This advanced option is model specific and the setting is saved in the options database.

21.52 XS_USE_POINT_AS_SEPARATOR_IN_PROFILE_NAME

Category

Profiles

Set this advanced option to `TRUE` to use the period character (.) as the separator in parametric profile names, instead of using it as a decimal separator. This increases the number of separators available in the US imperial environment. The default value is `FALSE`.

This advanced option is model specific and the setting is saved in the options database.

21.53 XS_USE_RECESS_SYMBOL_FOR_BORDER_AND_CORNER_RECESSES

Category: Drawing properties

Use `XS_USE_RECESS_SYMBOL_FOR_BORDER_AND_CORNER_RECESSES` to select whether to use the recess symbol in corner and border recesses. `TRUE` is the default value.

This advanced option is model specific and the setting is saved in the options database.

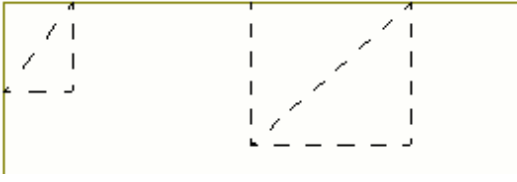
| Value | Description |
|-------|--|
| TRUE | <p>Recess symbol is used in the recesses located at the border or in the corner of the part. The symbol used depends on the setting of the advanced option <code>XS_USE_CROSS_FOR_OPENING_SYMBOL</code></p>  |

| Value | Description |
|-------|---|
| FALSE | <p>No recess symbol is used for recesses at the borders or in the corners of the part.</p>  |

See also

[XS_USE_CROSS_FOR_OPENING_SYMBOL](#) (page 472)

[XS_USE_OPENING_SYMBOL_IN_BORDER_HOLES](#) (page 487)

[XS_USE_OPENING_SYMBOL_IN_CORNER_HOLES](#) (page 488)

21.54 XS_USE_REPAIR_NUMBERING_INSTEAD_OF_NUMBERING

Category: Numbering

If this advanced option is set to `TRUE`, Tekla Structures automatically repairs numbering instead of only running numbering.

When this advanced option is set to `TRUE`:

- Using the **Number modified objects** command does the same as using the **Diagnose and repair numbering: All** command
- Using the **Number series of selected objects** command does the same as using the **Diagnose and repair numbering: Series of selected objects** command

The default value is `FALSE`.

This advanced option is model specific and the setting is saved in the options database.

21.55 XS_USE_ROUND_MAIN_PART_COORDINATES_FOR_SECONDARY_PART_ANGLE

Category

Dimensioning: Parts

Set to `TRUE` to have the secondary part skewed dimensions and angle dimension use one of the main part directions if the main part profile is round or round tube. The default value is `TRUE`.

This advanced option is model specific and the setting is saved in the options database.

21.56 XS_USE_SCREW_POINT_ELEVATION_DIM

Category

Dimensioning: Bolts

Set this advanced option to `TRUE` to display the elevation dimensions of a column to the working points of a neighboring part. If you set it to `FALSE`, the elevation dimensions are displayed at the ends of the column. The default value is `FALSE`.

This advanced option is model specific and the setting is saved in the options database.

Example

An example, where the value is `TRUE`:

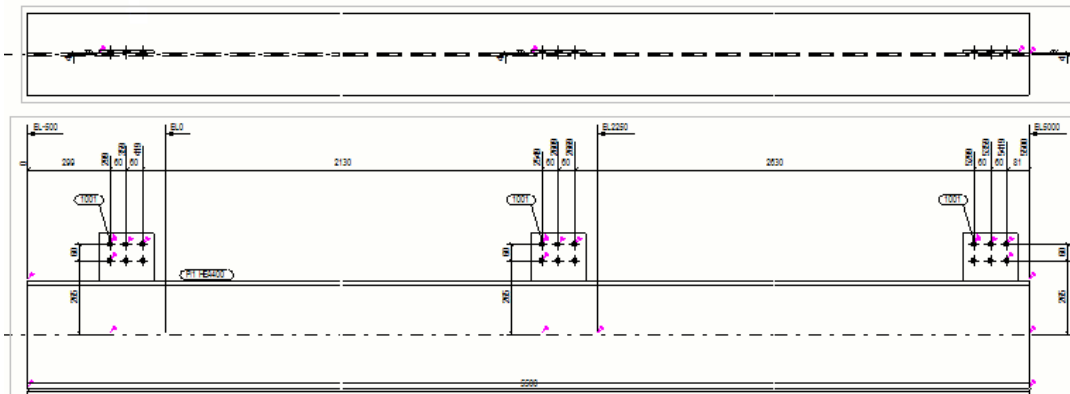

`\Trimble\Tekla Structures\<version>\UserSettings`. Restart Tekla Structures to activate the new value.

Restart Tekla Structures after changing the value to activate the new setting.

21.59 XS_USE_SMOOTH_LINES

Category

Model View

Set this advanced option to `TRUE` to use anti-aliasing to minimize jagged edges in model views. Before using this advanced option, check that your display adapter supports anti-aliasing. This advanced option is supported only for OpenGL rendering.

The default value is `FALSE`.

This advanced option is user specific and the setting is saved in `options.bin` under the user folder, for example, in `C:\Users\<user>\AppData\Local\Trimble\Tekla Structures\<version>\UserSettings`. Restart Tekla Structures to activate the new value.

21.60 XS_USE_SOFTWARE_RENDERING

Category

Model view

Set this advanced option to `TRUE` to bypass your graphic adapter in model views. Use this advanced option if you have problems with your display (for example, lines are not drawn correctly). The default value is `FALSE`.

This advanced option is user specific and the setting is saved in `options.bin` under the user folder, for example, in `C:\Users\<user>\AppData\Local\Trimble\Tekla Structures\<version>\UserSettings`. Restart Tekla Structures to activate the new value.

21.61 XS_USE_SPECIAL_FILLER_PLATE_THICKNESS

Category

Profiles

Set this advanced option to `TRUE` to have shim plate thicknesses comply with Japanese standards. The default value is `FALSE`.

This advanced option is model specific and the setting is saved in the options database.

21.62 XS_USE_TUBE_INNER_LENGTH_IN_DIMENSIONING

Category

Dimensioning: Parts

Set to `TRUE` to dimension the overall length of tube profiles along the inner surface instead of outer surface. The default value is `FALSE`.

This advanced option is model specific and the setting is saved in the options database.

21.63 XS_USE_UP_DOWN_SIGN_INDICATOR_FOR_ANGLE_IN_UNFOLDING

Category: Dimensioning - unfolding

Set this advanced option to `TRUE` to show Up and Down text instead of positive and negative angle values in unfolded single-part drawings for angle dimensions. `FALSE` is the default value.

Setting this advanced option to `TRUE` will omit the text specified for the advanced option

`XS_ANGLE_TEXT_IN_UNFOLDING_BENDING_LINE_DIMENSIONING`.



This advanced option is model specific and the setting is saved in the options database.

See also

[XS_DRAW_BENDING_END_LINE_DIMENSIONS_IN_UNFOLDING \(page 153\)](#)

21.64 XS_USE_USABSOLUTE_ARROW_TYPE_FOR_ABSOLUTE_DIMENSIONS

Category: Dimensioning - general

Set this advanced option to `TRUE` to use the arrow shape US Absolute also for normal absolute dimensions. `FALSE` is the default value.

You can select the arrow shape from the **US Absolute dimensions** list on the **Appearance** tab in the dimension properties dialog box.

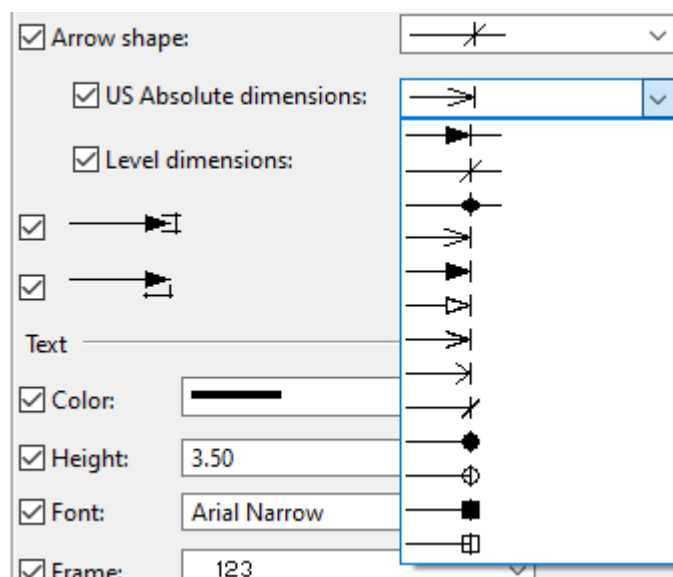

Note that this advanced option only applies to GA drawing dimensions, and old dimensioning ([XS_USE_OLD_DRAWING_CREATION_SETTINGS](#) (page 483) is set to `TRUE`).

This advanced option is model specific and the setting is saved in the options database.

21.65 XS_USE_USER_DEFINED_REBAR_LENGTH_AND_WEIGHT

Category

Concrete Detailing

Set this advanced option to `TRUE` to calculate the length and weight of the reinforcing bars in **Rebar Shape Manager** using formulas in the fields `L` and `WEIGHT`.

If you set this advanced option to `FALSE`, the length and the weight are automatically calculated according to the center line of the reinforcing bars. The default value is `FALSE`.

To read the length and weight from **Rebar Shape Manager**, you also have to set `XS_USE_USER_DEFINED_REBARSHAPERULES` to `TRUE`.

NOTE This setting only affects reports. If you set this advanced option to `TRUE` and you have not defined the formulas for length and weight in **Rebar Shape Manager**, the values in the reports show zero (0).

This advanced option is model specific and the setting is saved in the options database.

See also

[XS_USE_USER_DEFINED_REBARSHAPERULES \(page 497\)](#)

21.66 XS_USE_USER_DEFINED_REBARSHAPERULES

Category

Concrete Detailing

Use this advanced option to define whether reinforcing bar bending shapes are recognized according to the bending shape definitions created with **Rebar Shape Manager** and saved in the `RebarShapeRules.xml` file.

This advanced option is set to `TRUE` by default, meaning that the bending shape recognition uses the reinforcing bar shapes saved in the `RebarShapeRules.xml` file.

If you set this advanced option to `FALSE`, the **Rebar Shape Manager** definitions are not used, and the definitions in `rebar_schedule_config.inp` are used instead. We recommend that you set this advanced option to `TRUE` and use **Rebar Shape Manager**.

This advanced option is model specific and the setting is saved in the options database.

21.67 XS_USE_VERTICAL_PLACING_FOR_COLUMNS_IN

Category: Drawing properties

Use to place columns vertically in single part, assembly and cast unit drawings. Use the following options to specify the types of drawings where the columns should be placed vertically:

- ASSEMBLY_DRAWINGS - in assembly drawings and cast unit drawings only
- SINGLE_PART_DRAWINGS - in single part drawings only
- ASSEMBLY_AND_SINGLE_PART_DRAWINGS - in single part, assembly and cast unit drawings

This advanced option is model specific and the setting is saved in the options database.

21.68 XSUSERDATADIR

Category

This advanced option must be set in an initialization (.ini) file.

This advanced option is system specific and is read from `teklastructures.ini`. Generally, there is no need to modify system-specific settings. Do not modify them if you are not an administrator.

Example

```
set XSUSERDATADIR=%LOCALAPPDATA%\Tekla Structures\<>version
number>.
```

For example, `C:\Users\<>user>\AppData\Local\Trimble\Tekla Structures\<>version>\UserSettings`.

21.69 XS_USER_DEFINED_BOLT_SYMBOL_TABLE

Category: Marking - bolts

Defines the location of the user-defined bolt symbol table file. For example, enter `bolt_symbol_table.txt`.

This advanced option is model specific and the setting is saved in the options database.

21.70 XS_USER_DEFINED_PARAMETRIC_PROFILE_SEPARATORS

Category

Profiles

Use this advanced option to define additional separators to separate dimensions in the names of parametric profiles. The separators can consist of multiple characters.

Separate the values with commas, for example `GA, ABC`.

WARNING Follow these rules in naming:

- Use uppercase letters in separator names.
- Do not enter digits, commas, or special characters in separator names.
- Do not start separator names with a dash (-) or full stop (.).
- Do not start separator names with an inch separator (" , ' /) when using imperial units.

In addition to these characters, Tekla Structures always recognizes the standard separator characters `X`, `*`, `-`, and `/`, and also the character defined by the advanced option `XS_PARAMETRIC_PROFILE_SEPARATOR` (page 326).

21.71 XS_USER_SETTINGS_DIRECTORY

Category

This advanced option must be set in an initialization (.ini) file. It is system-specific.

This advanced option is set as a Windows environment variable in the Windows system properties.

The path to the folder that contains the `user.ini` file and the `options.bin` file.

The default value is `%XSUSERDATADIR%\UserSettings\`

See also

[XSUSERDATADIR \(page 498\)](#)

22 Advanced options - V

22.1 XS_VALID_CHARS_FOR_ASSEMBLY_FAMILY_POSITION_NUMBERS

Category

Numbering

Specifies valid letters for assembly family position numbers. You must specify all the valid letters in this advanced option. By default, the letters A- Z are valid.

For example, you might not want to use D, because it is easy to mix up with O and 0. In this case you would enter letters A - Z but leave out D.

This advanced option is model specific and the setting is saved in the options database.

See also

[XS_ASSEMBLY_FAMILY_POSITION_NUMBER_FORMAT_STRING \(page 53\)](#)

22.2 XS_VALID_CHARS_FOR_ASSEMBLY_FAMILY_QUALIFIER

Category

Numbering

Specifies valid letters for the assembly family number qualifier. You must specify all the valid letters in this advanced option. By default, the letters A - Z are valid.

For example, you might not want to use D, because it is easy to mix it up with O and 0. In this case you would enter letters A - Z but leave out D.

This advanced option is model specific and the setting is saved in the options database.

Example

```
XS_VALID_CHARS_FOR_ASSEMBLY_FAMILY_QUALIFIER=GHJKL
```

See also

[XS_ASSEMBLY_FAMILY_POSITION_NUMBER_FORMAT_STRING \(page 53\)](#)

22.3 XS_VALID_CHARS_FOR_ASSEMBLY_MULTI_NUMBERS

Category: Numbering

Use to specify the valid letters for assembly multinumbers. You must specify all the valid letters in this advanced option. By default, letters A - Z are valid.

This advanced option is model specific and the setting is saved in the options database.

Example

```
XS_VALID_CHARS_FOR_ASSEMBLY_MULTI_NUMBERS=ABEG
```

See also

[XS_USE_MULTI_NUMBERING_FOR \(page 480\)](#)

[XS_ASSEMBLY_MULTI_NUMBER_FORMAT_STRING \(page 55\)](#)

[XS_MIN_NUMBER_OF_ASSEMBLY_MULTI_CHARACTERS \(page 305\)](#)

[XS_VALID_CHARS_FOR_PART_MULTI_NUMBERS \(page 502\)](#)

22.4 XS_VALID_CHARS_FOR_ASSEMBLY_POSITION_NUMBERS

Category

Numbering

Specifies valid characters for assembly position numbers. Enter all the valid letters, for example, ABEG. By default, letters A - Z are valid.

This advanced option is model specific and the setting is saved in the options database.

See also

[XS_ASSEMBLY_POSITION_NUMBER_FORMAT_STRING \(page 58\)](#)

22.5 XS_VALID_CHARS_FOR_PART_MULTI_NUMBERS

Category: Numbering

Use to specify the valid letters for part multinumbers. You must specify all the valid letters in this advanced option. By default, letters a - z are valid.

This advanced option is model specific and the setting is saved in the options database.

Example

```
XS_VALID_CHARS_FOR_PART_MULTI_NUMBERS=abeg
```

See also

[XS_USE_MULTI_NUMBERING_FOR \(page 480\)](#)

[XS_PART_MULTI_NUMBER_FORMAT_STRING \(page 327\)](#)

[XS_MIN_NUMBER_OF_PART_MULTI_CHARACTERS \(page 305\)](#)

[XS_VALID_CHARS_FOR_ASSEMBLY_MULTI_NUMBERS \(page 501\)](#)

22.6 XS_VALID_CHARS_FOR_PART_POSITION_NUMBERS

Category**Numbering**

Use to specify the valid characters for part position numbers. Enter all the valid letters. For example, ABEG. By default letters A - Z are valid.

This advanced option is model specific and the setting is saved in the options database.

See also

[XS_PART_POSITION_NUMBER_FORMAT_STRING \(page 328\)](#)

22.7 XS_VALID_CHARS_FOR_REBAR_SUB_ID_WITH_LETTERS

Category: Numbering

Use this advanced option to specify the valid letters for the reinforcing bar identifiers when they are shown by SUB_ID_WITH_LETTERS. Enter all the valid letters, for example, ABEG. By default, letters A-Z are valid.

This advanced option is model specific and the setting is saved in the options database.

See also

[XS_REBARSET_TAPERED_REBAR_POSITION_NUMBER_FORMAT_STRING](#)
(page 373)

22.8 XS_VIEW_DIM_LINE_COLOR

Category

Model View

Use to change the dimension line color in model views. Define the color using RGB values:

<value for red> <value for green> <value for blue>.

Separate the values with spaces. Define the values on a scale of 0 to 1. The default values are 1.0 0.0 1.0.

This advanced option is user specific and the setting is saved in `options.bin` under the user folder, for example, in `C:\Users\<user>\AppData\Local\Trimble\Tekla Structures\<version>\UserSettings`. Restart Tekla Structures to activate the new value.

Example

| RGB value | Color |
|-------------|--------|
| 1.0 1.0 1.0 | White |
| 1.0 0.0 0.0 | Red |
| 0.0 1.0 0.0 | Green |
| 0.0 0.0 1.0 | Blue |
| 1.0 1.0 0.0 | Yellow |

22.9 XS_VIEW_DIM_TEXT_COLOR

Category

Model View

Use to change the dimension text color in model views. Define the color using RGB values:

<value for red> <value for green> <value for blue>.

Separate the values with spaces. Define the values on a scale of 0 to 1. The default values are 0.0 0.0 0.0.

This advanced option is user specific and the setting is saved in `options.bin` under the user folder, for example, in `C:\Users\<user>\AppData\Local\Trimble\Tekla Structures\<version>\UserSettings`. Restart Tekla Structures to activate the new value.

Example

| RGB value | Color |
|-------------|--------|
| 1.0 1.0 1.0 | White |
| 1.0 0.0 0.0 | Red |
| 0.0 1.0 0.0 | Green |
| 0.0 0.0 1.0 | Blue |
| 1.0 1.0 0.0 | Yellow |

22.10 XS_VIEW_FAST_BOLT_COLOR

Category

Model View

Use to define the color of bolts in model views when you are using the representation option **Fast**. Define the color using RGB (Red Green Blue) values. The scale is from 0 to 1. Separate the numbers with spaces. The default color is white 1.0 1.0 1.0.

This advanced option is user specific and the setting is saved in `options.bin` under the user folder, for example, in `C:\Users\<user>\AppData\Local\Trimble\Tekla Structures\<version>\UserSettings`. Restart Tekla Structures to activate the new value.

Example

To change the color to black, enter 0.0 0.0 0.0.

22.11 XS_VIEW_FRAMES_VISIBLE

Category: Drawing views

Set this advanced option to `FALSE` to hide drawing view frames until you move the mouse pointer over the view. This is the default value.

When you set this advanced option to `TRUE`, drawing view frames are visible all the time.

This advanced option is user specific and the setting is saved in `options.bin` under the user folder, for example, in `C:\Users\\AppData\Local\Trimble\Tekla Structures\\UserSettings`. Restart Tekla Structures to activate the new value.

22.12 XS_VIEW_FREE_MEASURE_PLANE

Category

Model View

Use to define the plane where the results of free measure are shown. You can have the distances displayed in the local and/or global coordinate system.

The possible values are `VIEW`, `WORK` and `BOTH`. The default value is `VIEW`.

NOTE If you set the advanced option to `BOTH`, only one value is shown if the values are identical.

Example

In the following example, the advanced option has been set to `BOTH`:

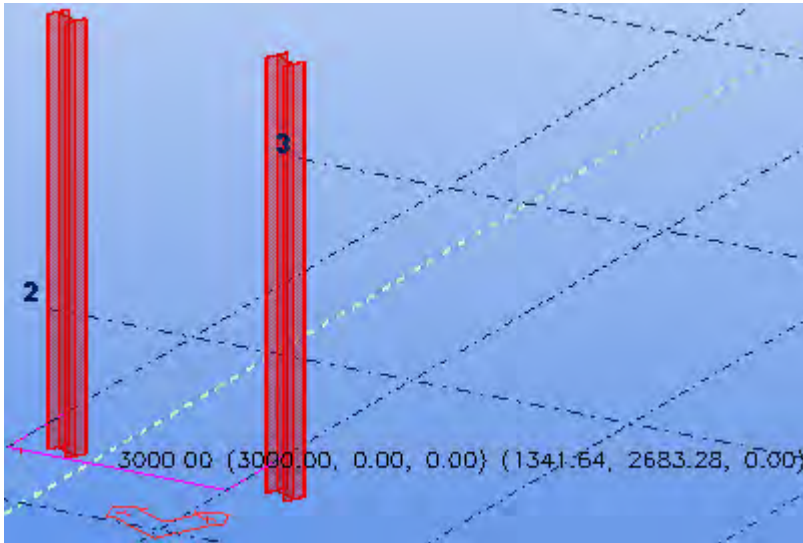

22.13 XS_VIEW_HEIGHT

Set this advanced option in the `user.ini` file located in `..\Users\\AppData\Local\Trimble\Tekla Structures\\UserSettings`.

Use to define the default height of model views. Enter the value in pixels.

See also

[XS_VIEW_WIDTH](#) (page 508)

22.14 XS_VIEW_PART_LABEL_COLOR

Category

Model View

Use to change the part label color in model views. Define the color using RGB values:

`<value for red> <value for green> <value for blue>`.

Separate the values with spaces. Define the values on a scale of 0 to 1. The default is black `0.0 0.0 0.0`.

This advanced option is user specific and the setting is saved in `options.bin` under the user folder, for example, in `C:\Users\\AppData\Local\Trimble\Tekla Structures\\UserSettings`.

Example

| RGB value | Color |
|-------------|--------|
| 1.0 1.0 1.0 | White |
| 1.0 0.0 0.0 | Red |
| 0.0 1.0 0.0 | Green |
| 0.0 0.0 1.0 | Blue |
| 1.0 1.0 0.0 | Yellow |

22.15 XS_VIEW_POSITION_X

Category

Model View

Use to define the default horizontal position of view windows. Origin is in the top left corner of the Tekla Structures or client window. Enter the position in pixels. The default value is 10.

This advanced option is user specific and the setting is saved in `options.bin` under the user folder, for example, in `C:\Users\\AppData\Local\Trimble\Tekla Structures\\UserSettings`. Restart Tekla Structures to activate the new value.

22.16 XS_VIEW_POSITION_Y

Category

Model view

Use to define the default vertical position of view windows. Origin is in the top left corner of the Tekla Structures or client window. Enter the position in pixels. The default value is 10.

This advanced option is user specific and the setting is saved in `options.bin` under the user folder, for example, in `C:\Users\\AppData\Local\Trimble\Tekla Structures\\UserSettings`. Restart Tekla Structures to activate the new value.

22.17 XS_VIEW_TITLE_FONT

Category

Drawing View

Use to specify the font for view direction marks. The default value is Arial. If this advanced option is not set, Tekla Structures uses the font specified for XS_DEFAULT_FONT.

TIP If you want to change the view label font, go to **View Properties --> Mark Contents** and change the font.

See also

[XS_DEFAULT_FONT \(page 116\)](#)

22.18 XS_VIEW_WIDTH

Set this advanced option in the `user.ini` file located in `..\Users\<>user>\AppData\Local\Trimble\Tekla Structures\<>version>\UserSettings`.

Use to define the default width of model views. Enter the value in pixels.

See also

[XS_VIEW_HEIGHT \(page 506\)](#)

22.19 XS_VISUALIZE_VIEW_IN_ANOTHER_VIEWS

Category

Drawing View

Set this advanced option to `TRUE` if you want to highlight the view boundary of the selected view in another view. If you do not want to highlight the view boundary in another view, set this advanced option to `FALSE`. The default value is `TRUE`.

This advanced option is user specific and the setting is saved in `options.bin` under the user folder, for example, in `C:\Users\<>user>\AppData\Local\Trimble\Tekla Structures\<>version>\UserSettings`. Restart Tekla Structures to activate the new value.

22.20 XS_VISUALIZE_VIEW_IN_FATHER_VIEW_ONLY

Category

Drawing View

Set this advanced option to `TRUE` if you want to visualize the section view and detail view boundary boxes only in the view where the section mark or the detail mark is located. If you set this advanced option to `FALSE`, the view boundary boxes are visualized in all of the views where this is possible and the boundary box fits inside the view to some extent. The default value is `TRUE`.

This advanced option is user specific and the setting is saved in `options.bin` under the user folder, for example, in `C:\Users\\AppData\Local\Trimble\Tekla Structures\\UserSettings`. Restart Tekla Structures to activate the new value.

See also

[XS_VISUALIZE_VIEW_IN_ANOTHER_VIEWS \(page 508\)](#)

22.21 XS_VISUALIZE_VIEW_NEIGHBOUR_PART_EXTENSION

Category: Drawing views

Set this advanced option to `TRUE` to show neighbor part extensions in drawing views. If you set this advanced option to `FALSE`, the neighbor part extensions are not shown. The default value is `TRUE`.

When you select a view, the view extension for neighbor parts for that view is also shown in other views.

NOTE If neighbor parts are hidden by setting **Neighbor parts** to **None** in the **Neighbor Part Properties** dialog box, neighbor part extensions are not displayed even if you set this advanced option to `TRUE`.

This advanced option is user specific and the setting is saved in `options.bin` under the user folder, for example, in `C:\Users\\AppData\Local\Trimble\Tekla Structures\\UserSettings`. Restart Tekla Structures to activate the new value.

23 Advanced options - W

23.1 XS_WARP_MAX_ANGLE_BETWEEN_CS

Category

Concrete Detailing

Use to define the maximum angle between adjacent polygonal parts of the warped shape.

Enter the value in degrees. You get best results if you use values between 0.5 - 10.0. The default value is 0.5.

This advanced option is model specific and the setting is saved in the options database.

23.2 XS_WARP_MAX_DEVIATION

Category

Concrete Detailing

Use to define the maximum difference between real warped shape and the polygonal warped shape in the model.

Enter the value in millimeters. You get best results if you use values between 5.0 -100.0. The default value is 10.0.

This advanced option is model specific and the setting is saved in the options database.

23.3 XS_WELD_FILTER_TYPE

Category: Welds

Use to define how Tekla Structures filters weld types.

- **EXACT:** Tekla Structures filters the welds equal to the default size in the weld properties.
- **MIN:** Tekla Structures filters all welds equal to or smaller than the default size in the weld properties. This is the default value.

This advanced option is model specific and the setting is saved in the options database.

See also

Model weld mark properties in drawings

23.4 XS_WELD_FONT

Category

Drawing Properties

Use to specify the font for weld text. The default value is Arial. If this advanced option is not set, Tekla Structures uses the default font defined for `XS_DEFAULT_FONT`.

See also

[XS_DEFAULT_FONT](#) (page 116)

23.5 XS_WELDING_LENGTH_TOLERANCE

Category

Welds

Use to specify the minimum edge length Tekla Structures should take into account when searching for a location for a weld. The default value is 30 mm.

This advanced option is model specific and the setting is saved in the options database.

23.6 XS_WELDING_TOUCH_TOLERANCE

Category: **Welds**

Use to define the maximum possible gap between two parts welded together when copying secondary parts. The weld is copied together with the part if the copied part is within the defined tolerance from the main part. Otherwise, the part is copied without the weld.

The default value is 30 mm.

This advanced option is model specific and the setting is saved in the options database.

23.7 XS_WELD_LENGTH_CC_SEPARATOR_CHAR

Category: **Welds**

Use this advanced option to set the separator character used in the weld mark between the weld length and the pitch (center-to-center spacing) of weld segments. Enter @ to define the separator character according to the AISC standard (3@12). Enter - to define the separator character according to the ISO standard (100-300). The default value is -.

This advanced option is model specific and the setting is saved in the options database.

23.8 XS_WELD_NUMBER_FORMAT

Category

Marking: **General**

Use to define the weld number format.

This advanced option is model specific and the setting is saved in the options database.

Example

In `XS_WELD_NUMBER_FORMAT=W%3.3d`:

- `w` is the prefix. The rest of the string defines the number format.
- The first number defines the minimum field width.
- The second number defines the minimum quantity of numbers to display.
- `%` and `d` (integer value) indicate the format.

See also

[XS_JOINT_NUMBER_FORMAT](#) (page 274)

23.9 XS_WORKING_POINTS_VALID_ALSO_OUTSIDE_PART

Category

Dimensioning: Parts

Set this advanced option to `TRUE` to also draw reference dimensions for points outside part end points. The default value is `FALSE`.

This advanced option is model specific and the setting is saved in the options database.

23.10 XS_ZERO_POINT_SYMBOL_OLD_WAY

Category

Dimensioning: General

Set this advanced option to `TRUE` to use RD marks containing a circle rather than the text `RD` to indicate the zero point of dimensions when you use US Absolute dimension types. By default, RD marks contain the text `RD`. The default value is `FALSE`.

This advanced option is model specific and the setting is saved in the options database.

24 Advanced options - Z

24.1 XS_ZOOM_STEP_RATIO

Category

Model View

Use to configure the **Zoom in** and **Zoom out** commands. The default value is 0.25. Increase this value to zoom more with a single mouse click.

This advanced option is user specific and the setting is saved in `options.bin` under the user folder, for example, in `C:\Users\<user>\AppData\Local\Trimble\Tekla Structures\<version>\UserSettings`. Restart Tekla Structures to activate the new value.

24.2 XS_ZOOM_STEP_RATIO_IN_MOUSEWHEEL_MODE

Category

Model View

Set the zoom ratio when you are scrolling using the middle mouse button. Enter a decimal value. Increase the value to zoom more with a single mouse click. The default value is 0.05.

This advanced option is user specific and the setting is saved in `options.bin` under the user folder, for example, in `C:\Users\<user>\AppData\Local\Trimble\Tekla Structures\<version>\UserSettings`. Restart Tekla Structures to activate the new value.

24.3 XS_ZOOM_STEP_RATIO_IN_SCROLL_MODE

Category

Model View

Set the zoom ratio when scrolling and holding down the wheel. Enter a decimal value. Increase the value to zoom more with a single mouse click. The default value is 0.01.

This advanced option is user specific and the setting is saved in `options.bin` under the user folder, for example, in `C:\Users\<user>\AppData\Local\Trimble\Tekla Structures\<version>\UserSettings`. Restart Tekla Structures to activate the new value.

25 Disclaimer

© 2023 Trimble Solutions Corporation and its licensors. All rights reserved.

This Software Manual has been developed for use with the referenced Software. Use of the Software, and use of this Software Manual are governed by a License Agreement. Among other provisions, the License Agreement sets certain warranties for the Software and this Manual, disclaims other warranties, limits recoverable damages, defines permitted uses of the Software, and determines whether you are an authorized user of the Software. All information set forth in this manual is provided with the warranty set forth in the License Agreement. Please refer to the License Agreement for important obligations and applicable limitations and restrictions on your rights. Trimble does not guarantee that the text is free of technical inaccuracies or typographical errors. Trimble reserves the right to make changes and additions to this manual due to changes in the software or otherwise.

In addition, this Software Manual is protected by copyright law and by international treaties. Unauthorized reproduction, display, modification, or distribution of this Manual, or any portion of it, may result in severe civil and criminal penalties, and will be prosecuted to the full extent permitted by law.

Tekla Structures, Tekla Model Sharing, Tekla PowerFab, Tekla Structural Designer, Tekla Tedds, Tekla Civil, Tekla Campus, Tekla Downloads, Tekla User Assistance, Tekla Discussion Forum, Tekla Warehouse and Tekla Developer Center are either registered trademarks or trademarks of Trimble Solutions Corporation in the European Union, the United States, and/or other countries. More about Trimble Solutions trademarks: <http://www.tekla.com/tekla-trademarks>. Trimble is a registered trademark or trademark of Trimble Inc. in the European Union, in the United States and/or other countries. More about Trimble trademarks: <http://www.trimble.com/trademarks.aspx>. Other product and company names mentioned in this Manual are or may be trademarks of their respective owners. By referring to a third-party product or brand, Trimble does not intend to suggest an affiliation with or endorsement by such third party and disclaims any such affiliation or endorsement, except where otherwise expressly stated.

Portions of this software:

EPM toolkit © 1995-2006 Jotne EPM Technology a.s., Oslo, Norway. All rights reserved.

Portions of this software make use of Open CASCADE Technology software.
Open Cascade Express Mesh Copyright © 2019 OPEN CASCADE S.A.S. All rights reserved.

PolyBoolean C++ Library © 2001-2012 Complex A5 Co. Ltd. All rights reserved.

FLY SDK - CAD SDK © 2012 VisualIntegrity™. All rights reserved.

This application incorporates Open Design Alliance software pursuant to a license agreement with Open Design Alliance. Open Design Alliance Copyright © 2002-2020 by Open Design Alliance. All rights reserved.

CADhatch.com © 2017. All rights reserved.

FlexNet Publisher © 2016 Flexera Software LLC. All rights reserved.

This product contains proprietary and confidential technology, information and creative works owned by Flexera Software LLC and its licensors, if any. Any use, copying, publication, distribution, display, modification, or transmission of such technology in whole or in part in any form or by any means without the prior express written permission of Flexera Software LLC is strictly prohibited. Except where expressly provided by Flexera Software LLC in writing, possession of this technology shall not be construed to confer any license or rights under any Flexera Software LLC intellectual property rights, whether by estoppel, implication, or otherwise.

To see the third party open source software licenses, go to Tekla Structures, click **File menu** --> **Help** --> **About Tekla Structures** --> **3rd party licenses** and then click the option.

The elements of the software described in this Manual are protected by several patents and possibly pending patent applications in the United States and/or other countries. For more information, go to page <http://www.tekla.com/tekla-patents>.

Index

| | |
|---|------------|
| A | |
| accuracy..... | 40 |
| in modeling..... | 444 |
| of parts..... | 444 |
| of profiles..... | 444 |
| adaptivity..... | 41 |
| advanced options..... | 27 |
| AISC weld marks..... | 42 |
| anti-aliasing..... | 494 |
| application error log..... | 50 |
| arrows | |
| reinforcing bar dimension lines..... | 352 |
| assemblies | |
| numbering loose parts..... | 470 |
| asterisk..... | 90 |
| AutoConnection | |
| connecting built-in members..... | 102 |
| tolerance..... | 61 |
| UDL..... | 61 |
| autosave | |
| folder..... | 63 |
| B | |
| background color..... | 64 |
| basic view | |
| height..... | 66 |
| horizontal position..... | 67 |
| vertical position..... | 67 |
| width..... | 68 |
| bolt mark contents | |
| size..... | 73,405,432 |
| bolts in drawings | |
| filtering away bolt types..... | 321 |
| omitting bolt types..... | 321 |
| bolts | |
| bolt axis representation..... | 76 |
| marks..... | 72 |
| BS..... | 315,316 |
| C | |
| c/c format..... | 86 |
| chamfer | |
| accuracy..... | 86,111 |
| length accuracy..... | 87 |
| change symbol..... | 258 |
| CIMsteel | |
| database name..... | 94 |
| database path..... | 94 |
| express file..... | 95 |
| password..... | 94 |
| clash check | |
| reinforcing bars..... | 95 |
| CNC.... | |
| 97,206,208,209,210,211,212,213,214,215, | |
| 306,395 | |
| color | |
| background..... | 64 |
| colors | |
| in drawings..... | 471 |
| pour breaks..... | 342 |
| pour objects..... | 343 |
| column marks | |
| angle..... | 147 |
| columns | |
| mark text angle..... | 147 |
| column | |
| vertically in drawings..... | 497 |
| company settings..... | 98 |
| company.ini..... | 98 |
| components | |
| page 10..... | 447 |
| page 9..... | 447 |
| connecting side symbol | |
| changing..... | 101 |
| connecting side mark..... | 304 |
| connecting side symbol..... | 242 |

D

| | |
|---------------------------------------|---------|
| design values..... | 32 |
| destination folder..... | 306 |
| detail views..... | 509 |
| diameter prefix..... | 71 |
| dimension point change symbol..... | 258 |
| dimension tags | |
| tag D..... | 132 |
| dimensions | |
| dimension line color..... | 503 |
| extension line origin offset..... | 129 |
| tags..... | 132 |
| text color..... | 503 |
| dragging | |
| drawing views..... | 89 |
| drawing sheet position on screen..... | 193 |
| drawing views | |
| exporting frames..... | 333 |
| printing frames..... | 333 |
| drawing views | |
| dragging..... | 89 |
| neighbor part visibility..... | 509 |
| visualizing detail views..... | 509 |
| visualizing section views..... | 509 |
| drawings | |
| opening maximized..... | 323 |
| DSTV | |
| preventing unfolding..... | 208 |
| DWG | |
| importing..... | 216,265 |
| DXF | |
| file size..... | 253 |
| text height..... | 218 |

E

| | |
|-----------------------------------|-----|
| environments..... | 114 |
| extrema, see view boundaries..... | 508 |

F

| | |
|--|-----|
| filtering away bolt types in drawings..... | 321 |
| filtering | |
| separator..... | 238 |
| firm folder..... | 238 |
| fixed..... | 89 |

| | |
|--------------------------|---------|
| flat bars..... | 91 |
| designation..... | 477 |
| setting the prefix..... | 239 |
| thickness tolerance..... | 240 |
| tolerance..... | 240 |
| font | |
| default..... | 116 |
| default font size..... | 117 |
| for cut symbol..... | 112 |
| for dimension..... | 130 |
| for DXF..... | 218 |
| for grid text..... | 247 |
| for reports..... | 344 |
| in marks..... | 289 |
| forces..... | 32 |
| FS..... | 315,316 |

G

| | |
|------------------------|-----|
| gage format..... | 85 |
| GOL format..... | 242 |
| graphic adapter | |
| overriding..... | 494 |
| grids | |
| overall dimension..... | 245 |

H

| | |
|-----------------------------|-------------|
| hard stamps..... | 395 |
| hatches | |
| in drawings..... | 165 |
| haunch profiles | |
| showing in drawings..... | 201 |
| Help | |
| location..... | 251 |
| hole marks | |
| size..... | 407,434 |
| size of slotted holes..... | 282,410,436 |
| holes | |
| slotted hole dimension..... | 167 |

I

| | |
|--------------------|-----|
| importing DWG..... | 265 |
| importing | |
| DWG files..... | 216 |

| | |
|---------------------------|-----|
| inch symbols | |
| in dimensions..... | 43 |
| inches | |
| disabling..... | 390 |
| symbol in dimensions..... | 43 |
| symbol in welds..... | 44 |
| ISO weld marks..... | 42 |

L

| | |
|--|-----|
| licenses | |
| setting default license for a user role. | 118 |
| line spaces | |
| marks..... | 295 |
| texts..... | 295 |
| line width..... | 65 |
| locale..... | 446 |

M

| | |
|---------------------------------|-------------|
| marks | |
| bolts..... | 72 |
| line space..... | 295 |
| space between elements..... | 288 |
| MIS..... | 306 |
| model views | |
| overriding graphic adapter..... | 494 |
| modeling | |
| more accurately..... | 444 |
| moving | |
| views on screen..... | 302 |
| multi-byte languages..... | 446 |
| multidrawings | |
| view title..... | 53,242 |
| multinumbers..... | 310,480,481 |
| available characters..... | 501,502 |
| format..... | 55,82,327 |
| model prefix..... | 308,479 |
| number of characters..... | 305 |
| numeric..... | 483 |
| order..... | 450 |
| view title..... | 310 |

N

| | |
|---|---------|
| NC.... | |
| 97,206,208,209,210,211,212,213,214,215, | 306,395 |
| NC files | |
| error..... | 97 |
| inner shape options..... | 206 |
| notch corner roundings..... | 206 |
| neighbor parts | |
| view extensions..... | 509 |
| north mark symbol..... | 315 |
| hidden..... | 253 |
| in GA drawings..... | 243,244 |
| scale..... | 315 |
| scale in GA drawings..... | 244 |
| NS..... | 315,316 |

O

| | |
|--------------------------------------|-----|
| omitting bolt types in drawings..... | 321 |
| opening | |
| drawings maximized..... | 323 |
| orientation mark..... | 253 |
| orientation marks..... | 244 |

P

| | |
|----------------------------------|---------|
| parts | |
| representation..... | 182 |
| shortening in views..... | 416,417 |
| placing | |
| fixed..... | 89 |
| polybeam length calculation..... | 79,485 |
| pour breaks | |
| colors..... | 342 |
| symbol..... | 343 |
| pour objects | |
| colors..... | 343 |
| pours..... | 223 |
| printing | |
| dialog..... | 378 |
| drawing title..... | 474 |
| remembering dialog values..... | 378 |
| to file..... | 182,183 |
| profiles | |
| accuracy..... | 444 |

protecting areas..... 471
pull-outs..... 357

R

Rebar Shape Manager..... 497
rebars
 dimension line symbols..... 352
RebarShapeRules.xml..... 497
reference lines
 in drawings..... 181
reference models
 reference cache..... 376
reference points
 size..... 192
reinforcement
 checking shape..... 359
 hooks..... 359
reinforcing bars
 clash check..... 95
 dimension line symbols..... 352
 length and weight..... 496
relative path in file location..... 306
representation
 parts..... 182
restriction box, see view boundaries..... 508
roles
 setting default role for a user..... 118
 setting up ribbon..... 385,386
rows
 in templates..... 473
 template rows..... 473

S

SDNF..... 394
section views..... 509
 rotation..... 387
sheet
 position on screen..... 193
shortening
 parts in views..... 416,417
slotted hole mark contents
 size..... 410,436
snapping mode..... 277
 absolute..... 276
 global..... 277

 relative..... 278
snapping
 to end points..... 174
solid buffer size..... 443
stacked fractions..... 445
symbols
 reinforcing bar dimension lines..... 352

T

texts
 line space..... 295
timeout..... 240
tolerance..... 40

U

unfolding
 preventing in DSTV..... 208
units
 converting..... 105,106
user-specific settings..... 498

V

variables
 see advanced options..... 27
view boundaries
 seeing in other views..... 508
view extension for neighbor parts..... 509
view extrema, see view boundaries..... 508
view restriction box, see view boundaries
508

W

weld symbols..... 42
welds
 inches in weld marks..... 486
 minimum edge length..... 511
 reference line length..... 306

X

XS_USE_OLD_PLOT_DIALOG..... 182

Z

zooming

| | |
|------------------------------------|-----|
| defining zoom ratio..... | 514 |
| original..... | 222 |
| tolerance for mouse movements..... | 331 |